



TEST REPORT

Report No.: BUUN-ESH-P20111958B
Test Model: DHI-TF-C100/512GB
Received: Nov.23, 2020
ISSUED: Dec.05, 2020

Applicant: ZHEJIANG DAHUA VISION TECHNOLOGY CO.,
LTD.

Address: No.1199, Bin'an Road, Binjiang District, Hangzhou,
P.R. China

Issued By: BUREAU VERITAS ADT (Shanghai) Corporation

Lab Location: No. 829, Xinzhuan Road, Shanghai, P.R.China
(201612)

This test report consists of 61 pages in total. It may be duplicated completely for legal use with the approval of the applicant. It should not be reproduced except in full, without the written approval of our laboratory. The client should not use it to claim product certification, approval, or endorsement by A2LA, CNAS, or any government agency. The test results in the report only apply to the tested item. The test results in this report are traceable to the national or international standards.





**BUREAU
VERITAS**

Contents

1. TEST PROGRAM.....	4
2. Summary of Test Procedure and Test Results	5
3. Immunity Testing Performance Criteria Definition	8
4. Test Configuration of Equipment under Test	9
4.1. Manufacturer information.....	9
4.2. Feature of Equipment under Test.....	9
4.3. Description of support units	9
4.4. Measurement Uncertainty	9
5. Test of Conducted Emission	11
5.1. Test Limit	11
5.2. Test Procedures	13
5.3. Typical Test Setup	13
5.4. Measurement Equipment	14
5.5. Test Result and Data	15
5.6. Test Photographs	17
6. Test of Radiated Emission	18
6.1. Test Limit.....	18
6.2. Test Procedures	19
6.3. Typical Test Setup	19
6.4. Measurement Equipment	20
6.5. Test Result and Data (30MHz ~ 1GHz).....	21
6.6. Test Result and Data (1GHz ~ 6GHz).....	23
6.7. Test Photographs (30MHz ~ 1GHz).....	25
6.8. Test Photographs (1GHz ~ 6GHz).....	26
7. Electrostatic Discharge Immunity Test.....	27
7.1. Test Procedure.....	27
7.2. Test Setup for Tests Performed in Laboratory	28
7.3. Test Severity Levels	29
7.4. Measurement Equipment	29
7.5. Test Result and Data	30
7.6. Test Photographs	32
8. Radio Frequency electromagnetic field immunity test	33
8.1. Test Procedure.....	33
8.2. Test Severity Levels	33
8.3. TEST SETUP.....	34
8.4. Measurement Equipment	35
8.5. Test Result and Data	36
8.6. Test Photographs	38
9. Electrical Fast Transient/ Burst Immunity Test	39
9.1. Test Procedure.....	39
9.2. Test Severity Levels	39
9.3. TEST SETUP.....	40
9.4. Measurement Equipment	40
9.5. Test Result and Data.....	41



9.6. Test Photographs	43
10. Surge Immunity Test.....	44
10.1. Test Procedure.....	44
10.2. Test Severity Level	44
10.3. TEST SETUP.....	45
10.4. Measurement Equipment	45
10.5. Test Result and Data	46
10.6. Test Photographs	47
11. Conduction Disturbances induced by Radio-Frequency Fields.....	48
11.1. Test Procedure.....	48
11.2. Test Severity Levels	48
11.3. TEST SETUP	49
11.4. Measurement Equipment	49
11.5. Test Result and Data	50
11.6. Test Photographs	52
12. Power Frequency Magnetic Field Immunity Test	53
12.1. Test Setup.....	53
12.2. Test Severity Levels	53
12.3. Measurement Equipment	54
12.4. Test Result and Data	55
12.5. Test Photographs	56
13. Voltage Dips and Voltage Interruptions Immunity Test Setup.....	57
13.1. Test Conditions	57
13.2. TEST SETUP	57
13.3. Measurement Equipment	57
13.4. Test Result and Data	58
13.5. Test Photographs	60
14. Photographs of EUT	61



1. TEST PROGRAM

PRODUCT: C100 Micro SD Memory Card
TEST MODEL: DHI-TF-C100/512GB
SERIES MODEL: DHI-TF-C100/32GB; DHI-TF-C100/64GB; DHI-TF-C100/128GB;
DHI-TF-C100/256GB; DHI-TF-C100/512GB; TF-C100/32GB;
TF-C100/64GB; TF-C100/128GB; TF-C100/256GB; TF-C100/512GB;
DH-TF-C100/32GB; DH-TF-C100/64GB; DH-TF-C100/128GB;
DH-TF-C100/256GB; DH-TF-C100/512GB
APPLICANT: ZHEJIANG DAHUA VISION TECHNOLOGY CO.,LTD.
TESTED: Nov.23 to Dec.05, 2020
STANDARDS: **EN 55032: 2015+A11: 2020, Class B**
EN IEC 61000-3-2: 2019
EN 61000-3-3: 2013+A1: 2019
EN 55024: 2010+A1: 2015
EN 55035: 2017
EN 50130-4: 2011+A1: 2014

We, BUREAU VERITAS ADT (Shanghai) Corporation, declare that the equipment above has been tested and found compliance with the requirement limits of applicable standards. The test record, data evaluation and Equipment Under Test (EUT) configurations represented herein are true and accurate under the standards herein specified.

PREPARED BY : _____, **DATE:** _____

Leon Yun

Testing Engineer

APPROVED BY : _____, **DATE:** _____

Daniel Sun

EMC Lab Manager

2. Summary of Test Procedure and Test Results

EMISSION		
Test Item	Normative References	Test Result
Conducted Emission	EN 55032: 2015+A11: 2020	Meets the Class B requirements
Radiated Emission	EN 55032: 2015+A11: 2020	Meets the Class B requirements
Harmonic current emissions	EN IEC 61000-3-2: 2019	The rated input power of the EUT is less than 75W, the limits are not specified by this standard.
Voltage fluctuations & flicker	EN 61000-3-3: 2013+A1: 2019	The EUT does not produce significant voltage fluctuations of flicker.

IMMUNITY (EN 55024:2010+A1:2015)		
Test Item	Test Spec	Test Result
Electrostatic Discharge Immunity Test (ESD)	± 4 kV (contact discharge, HCP/VCP) ± 8 kV (Air discharge)	Meets the requirements of Performance Criterion A
Radio Frequency electromagnetic field immunity test (RS)	80-1000 MHz, 3V/m, 80%AM(1kHz)	Meets the requirements of Performance Criterion A
Electrical Fast Transient/ Burst Immunity Test (EFT)	AC Port: ± 1 kV, Signal Port: ± 0.5 kV	Meets the requirements of Performance Criterion A
Surge Immunity Test	AC Power Ports: Line to Line: ± 1 kV Line to earth: ± 2 kV	Meets the requirements of Performance Criterion A
Conduction Disturbances induced by Radio-Frequency Fields	0.15-80MHz, 3V, 80%AM(1KHz)	Meets the requirements of Performance Criterion A
Power Frequency Magnetic Field Immunity Test	50Hz, 1A/m	Meets the requirements of Performance Criterion A
Voltage Dips and Voltage Interruptions Immunity Test	Voltage dips: >95% Reduction, 0.5 Durations (Cycle)	Meets the requirements of Performance Criterion A
	30% Reduction, 25 Durations (Cycle)	Meets the requirements of Performance Criterion A
	Voltage interruptions: >95% Reduction, 250 Durations (Cycle)	Meets the requirements of Performance Criterion C

IMMUNITY (EN 55035:2017)		
Test Item	Test Spec	Test Result
Electrostatic Discharge Immunity Test (ESD)	± 4 kV (contact discharge, HCP/VCP) ± 8 kV (Air discharge)	Meets the requirements of Performance Criterion A
Radio Frequency electromagnetic field immunity test (RS)	80-1000 MHz, 3V/m, 80%AM(1KHz) 1800, 2600, 3500, 5000	Meets the requirements of Performance Criterion A
Electrical Fast Transient/ Burst Immunity Test (EFT)	AC Port: ± 1 kV, Signal Port: ± 0.5 kV	Meets the requirements of Performance Criterion A
Surge Immunity Test	AC Power Ports: Line to Line: ± 1 kV Line to earth: ± 2 kV	Meets the requirements of Performance Criterion A
Conduction Disturbances induced by Radio-Frequency Fields	0.15-10MHz, 3V; 10-30MHz, 3-1V 30-80MHz, 1V 80%AM(1KHz)	Meets the requirements of Performance Criterion A
Power Frequency Magnetic Field Immunity Test	50Hz, 1A/m	Meets the requirements of Performance Criterion A
Voltage Dips and Voltage Interruptions Immunity Test	Voltage dips: >95% Reduction, 0.5 Durations (Cycle)	Meets the requirements of Performance Criterion A
	30% Reduction, 25 Durations (Cycle)	Meets the requirements of Performance Criterion A
	Voltage interruptions: >95% Reduction, 250 Durations (Cycle)	Meets the requirements of Performance Criterion C

IMMUNITY (EN 50130-4: 2011+A1: 2014)		
Test Item	Test Spec	Test Result
EN 61000-4-11 Mains supply voltage variations	Unom+10%(supply voltage max) Unom-15%(supply voltage min)	Meets the requirements of Performance Criterion A
EN 61000-4-11 Mains supply voltage dips and short interruptions	Voltage dips: 20% Reduction, 250 Durations (Cycle) 30% Reduction, 25 Durations (Cycle) 60% Reduction, 10 Durations (Cycle)	Meets the requirements of Performance Criterion A
	Voltage interruptions: 100% Reduction, 250 Durations (Cycle)	Meets the requirements of Performance Criterion C
EN 61000-4-2 Electrostatic Discharge Immunity Test (ESD)	±6 kV (contact discharge, HCP/VCP) ±8 kV (Air discharge)	Meets the requirements of Performance Criterion A
EN 61000-4-3 Radio Frequency electromagnetic field immunity test (RS)	80-2700MHz, 10V/m, 80%AM(1KHz) 80-2700MHz, 10V/m, 1Hz(0.5s ON, 0.5s OFF)	Meets the requirements of Performance Criterion A
EN 61000-4-6 Conduction Disturbances induced by Radio-Frequency Fields	0.15-100MHz, 10V, 80%AM(1KHz) 0.15-100MHz, 10V, 1Hz(0.5s ON, 0.5s OFF)	Meets the requirements of Performance Criterion A
EN 61000-4-4 Electrical Fast Transient/ Burst Immunity Test (EFT)	Pulse : 5/50 ns, Repetition Rate: 100kHz Power line: ±2 kV Signal line: ±1 kV	Meets the requirements of Performance Criterion A
EN 61000-4-5 Surge Immunity Test	Waveform : 1.2/50µs(8/20µs) Line to Line: ±1 kV Line to earth: ±2 kV	Meets the requirements of Performance Criterion A

3. Immunity Testing Performance Criteria Definition

- Criterion A : The apparatus operate as intended during the test. No degradation of performance or loss of function is allowed below the performance level.
- Criterion B : The apparatus operate as intended after the test. No change of operating state and the stored data are allowed. During the test, degradation of performance is allowed.
- Criterion C : Temporary loss of function is allowed, provided the function is self-recoverable or can be restored by the operation of the controls, or by any operation specified in the instructions for use.

4. Test Configuration of Equipment under Test

4.1. Manufacturer information

Manufacturer : ZHEJIANG DAHUA VISION TECHNOLOGY CO.,LTD.

Address : No.1199, Bin'an Road, Binjiang District, Hangzhou, P.R. China

4.2. Feature of Equipment under Test

Product Name:	C100 Micro SD Memory Card
Test Model:	DHI-TF-C100/512GB
Series Model:	DHI-TF-C100/32GB; DHI-TF-C100/64GB; DHI-TF-C100/128GB; DHI-TF-C100/256GB; DHI-TF-C100/512GB; TF-C100/32GB; TF-C100/64GB; TF-C100/128GB; TF-C100/256GB; TF-C100/512GB; DH-TF-C100/32GB; DH-TF-C100/64GB; DH-TF-C100/128GB; DH-TF-C100/256GB; DH-TF-C100/512GB
Model Discrepancy:	All series models only have different storage capacity.
EUT Power Rating:	DC3.3V

Note: Please refer to user manual.

4.3. Description of support units

NO.	PRODUCT	BRAND	MODEL NO.
1	Camera	IMOU	A22E

4.4. Measurement Uncertainty

Where relevant, the following measurement uncertainty levels have been estimated for tests performed on the EUT as specified in CISPR 16-4-2 Ed 1.0.

This uncertainty represents an expanded uncertainty expressed at approximately the 95% confidence level using a coverage factor of $k=2$.

This lab's measurement uncertainty U_{Lab} , is low than U_{Cispr} , Table 1 – Values of U_{Cispr} of CISPR 16-4-2 Ed. 1.0, therefore compliance is deemed to occur if no measured disturbance exceeds the disturbance limit.

Measurement		Value
Conducted emissions		2.55 dB
Conducted emissions at telecom port		2.60 dB
Radiated emissions	30 MHz ~ 1GHz	3.22 dB
	Above 1GHz	2.89 dB

5. Test of Conducted Emission

5.1. Test Limit

Conducted Emissions were measured from 150 kHz to 30 MHz with a bandwidth of 9 kHz and return leads of the EUT according to the methods defined in European Standard EN 55032.

Table A.10 – Requirements for conducted emissions from the AC mains power ports of Class B equipment

Applicable to 1. AC mains power ports (3.1.1)				
Table clause	Frequency range MHz	Coupling device (see Table A.8)	Detector type / bandwidth	Class B limits dB(uV)
A10.1	0,15 to 0,5	AMN	Quasi Peak / 9 kHz	66 to 56
	0,5 to 5			56
	5 to 30			60
A10.2	0,15 to 0,5	AMN	Average / 9 kHz	56 to 46
	0,5 to 5			46
	5 to 30			50
Apply A10.1 and A10.2 across the entire frequency range.				

Table A.12 –Requirements for asymmetric mode conducted emissions from Class B equipment

Applicable to					
1. wired network ports (3.1.32) 2. optical fibre ports (3.1.25) with metallic shield or tension members 3. broadcast receiver tuner ports (3.1.8) 4. antenna ports (3.1.3)					
Table clause	Frequency range MHz	Coupling device (see Table A.8)	Detector type / bandwidth	Class B voltage limits dB(uV)	Class B current limits dB(uA)
A12.1	0,15 to 0,5	AAN	Quasi Peak / 9 kHz	84 to 74	n/a
	0,5 to 30			74	
	0,15 to 0,5	AAN	Average / 9 kHz	74 to 64	
	0,5 to 30			64	
A12.2	0,15 to 0,5	CVP and current probe	Quasi Peak / 9 kHz	84 to 74	40 to 30
	0,5 to 30			74	30
	0,15 to 0,5	CVP and current probe	Average / 9 kHz	74 to 64	30 to 20
	0,5 to 30			64	20
A12.3	0,15 to 0,5	Current Probe	Quasi Peak / 9 kHz	n/a	40 to 30
	0,5 to 30				30
	0,15 to 0,5	Current Probe	Average / 9 kHz		30 to 20
	0,5 to 30				20
<p>The choice of coupling device and measurement procedure is defined in Annex C.</p> <p>Screened ports including TV broadcast receiver tuner ports are measured with a common-mode impedance of 150 Ω. This is typically accomplished with the screen terminated by 150 Ω to earth.</p> <p>AC mains ports that also have the function of a wired network port shall meet the limits given in Table A.10.</p> <p>The measurement shall cover the entire frequency range.</p> <p>The application of the voltage and/or current limits is dependent on the measurement procedure used. Refer to Table C.1 for applicability.</p> <p>Measurement is required at only one EUT supply voltage and frequency.</p> <p>Applicable to ports listed above and intended to connect to cables longer than 3 m.</p>					

5.2. Test Procedures

- The EUT was placed on a desk 0.8 meter height from the metal ground plane and 0.4 meter from the conducting wall of the shielding room and it was kept at least 0.8 meter from any other grounded conducting surface.
- Connect EUT to the power mains through a Artificial Mains Network (AMN).
- All the support units are connecting to the other AMN.
- The AMN provides 50 ohm coupling impedance for the measuring instrument.
- The CISPR states that a 50 ohm, 50 micro-Henry AMN should be used.
- Both sides of AC line were checked for maximum conducted interference.
- The frequency range from 150 kHz to 30 MHz was searched.
- Set the test-receiver system to Peak Detect Function and Specified Bandwidth with Maximum Hold Mode.

5.3. Typical Test Setup

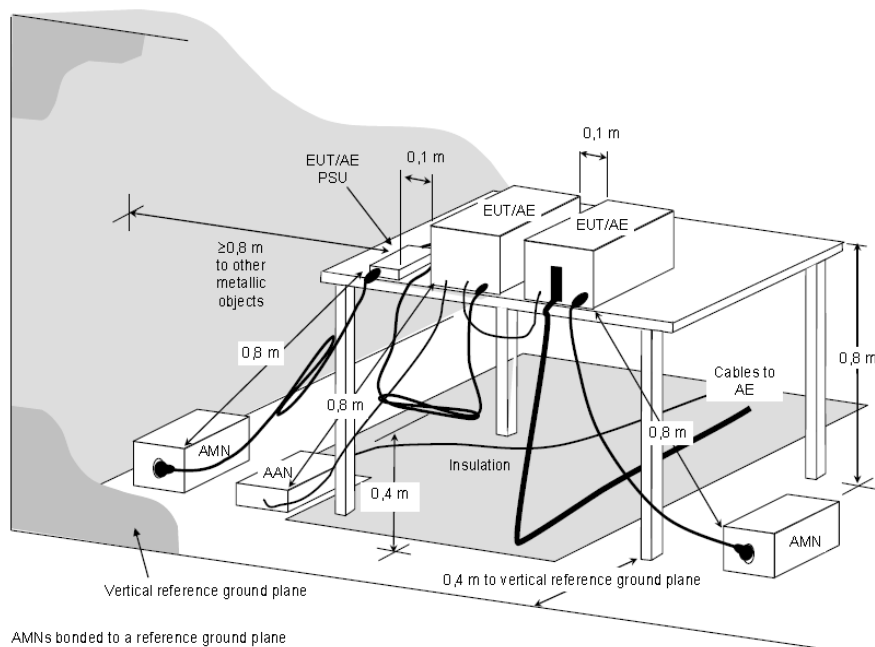

NOTE The 0,8 m distance specified between EUT/AE/PSU and AMN/AAN, is applicable only to the EUT being measured. If the device is AE then it shall be ≥0,8 m.

**Figure D.2 – Example measurement arrangement for table-top EUT
(Conducted emission measurement – alternative 1)**

5.4. Measurement Equipment

DESCRIPTION & MANUFACTURER	MODEL NO.	SERIAL NO.	CALIBRATED UNTIL
Test Receiver ROHDE & SCHWARZ	ESCS30	E1R1002	May.11, 2021
LISN ROHDE & SCHWARZ	ENV216	E1L1011	May.11, 2021
LISN	ISNT800	E1C4021	May.11, 2021
Software ADT	ADT_Cond_V7.3.0	N/A	N/A

5.5. Test Result and Data

5.5.1 Conducted Emission Test Data

Phase : LINE

Location: Conduction 1

Date: 11/28/2020

Time: 7:28:27 PM

Phase L1

Temperatuer (C): 23

Humidity (%): 53

Approved by:

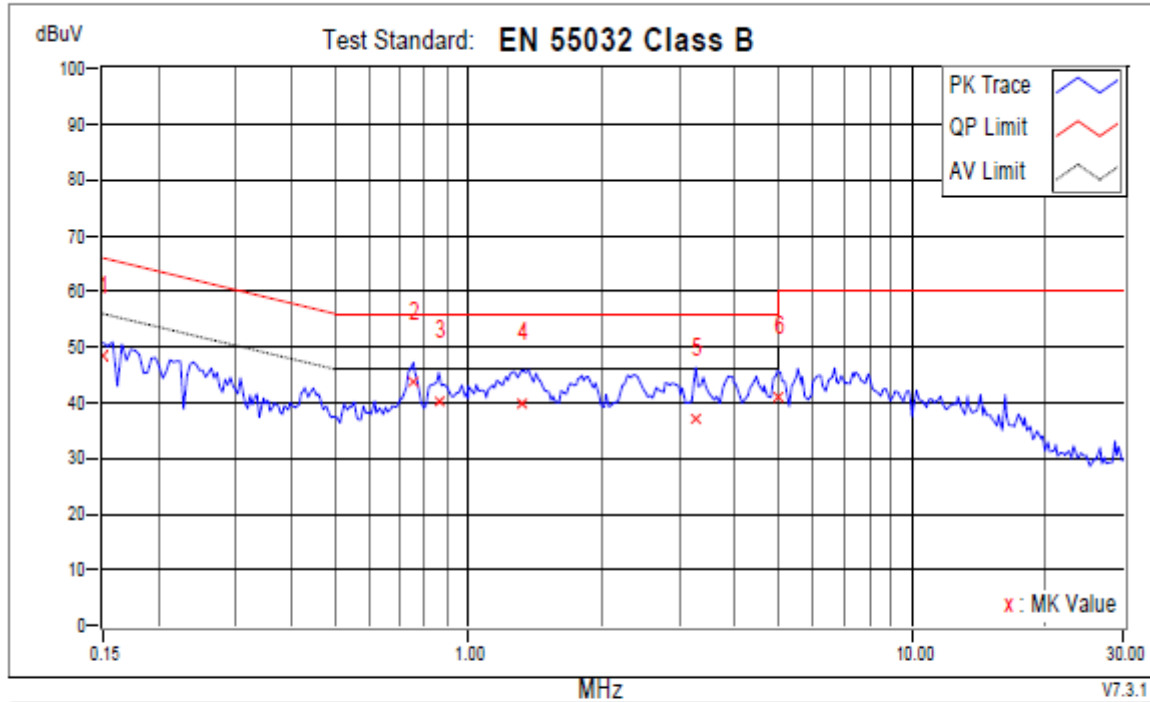

No.	Frequency	Corr. Factor	Reading dBuV		Emission dBuV		Limit dBuV		Margins dB		Notes
	MHz		QP	AV	QP	AV	QP	AV	QP	AV	
1	0.15000	9.87	38.70	18.23	48.57	28.10	66.00	56.00	-17.43	-27.90	
+2	0.75214	9.61	34.23	24.63	43.84	34.24	56.00	46.00	-12.16	-11.76	
3	0.85771	9.61	30.74	20.92	40.35	30.53	56.00	46.00	-15.65	-15.47	
4	1.31671	9.67	30.29	20.89	39.96	30.56	56.00	46.00	-16.04	-15.44	
5	3.25607	9.91	27.08	18.28	36.99	28.19	56.00	46.00	-19.01	-17.81	
6	5.00000	10.07	30.83	21.96	40.90	32.03	56.00	46.00	-15.10	-13.97	

REMARKS:

1. Q.P. and AV. are abbreviations of quasi-peak and average individually.
2. The emission levels of other frequencies were very low against the limit.
3. Margin value = Emission level - Limit value
4. Correction factor = Insertion loss + Cable loss
5. Emission Level = Correction Factor + Reading Value.

Phase : NEUTRAL

Location: Conduction 1

Date: 11/28/2020

Time: 7:41:26 PM

Phase N

Temperatur (C): 23

Humidity (%): 53

Approved by:

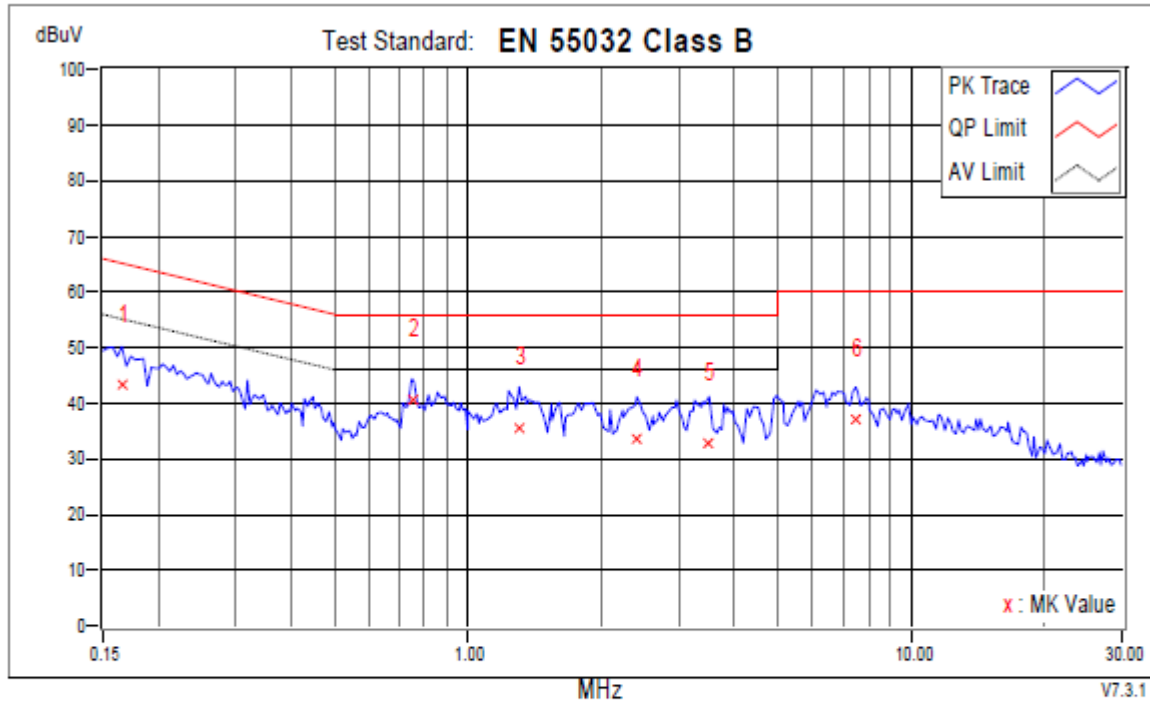

No.	Frequency MHz	Corr. Factor dB	Reading dBuV		Emission dBuV		Limit dBuV		Margins dB		Notes
			QP	AV	QP	AV	QP	AV	QP	AV	
1	0.16564	9.86	33.45	10.80	43.31	20.66	65.18	55.18	-21.86	-34.51	
+2	0.74823	9.87	30.78	21.60	40.65	31.47	56.00	46.00	-15.35	-14.53	
3	1.30498	9.92	25.55	14.40	35.47	24.32	56.00	46.00	-20.53	-21.68	
4	2.40369	9.99	23.69	14.38	33.68	24.37	56.00	46.00	-22.32	-21.63	
5	3.50240	9.97	22.76	13.52	32.73	23.49	56.00	46.00	-23.27	-22.51	
6	7.49842	10.22	26.78	17.37	37.00	27.59	60.00	50.00	-23.00	-22.41	

REMARKS:

1. Q.P. and AV. are abbreviations of quasi-peak and average individually.
2. The emission levels of other frequencies were very low against the limit.
3. Margin value = Emission level - Limit value
4. Correction factor = Insertion loss + Cable loss
5. Emission Level = Correction Factor + Reading Value.

5.6. Test Photographs

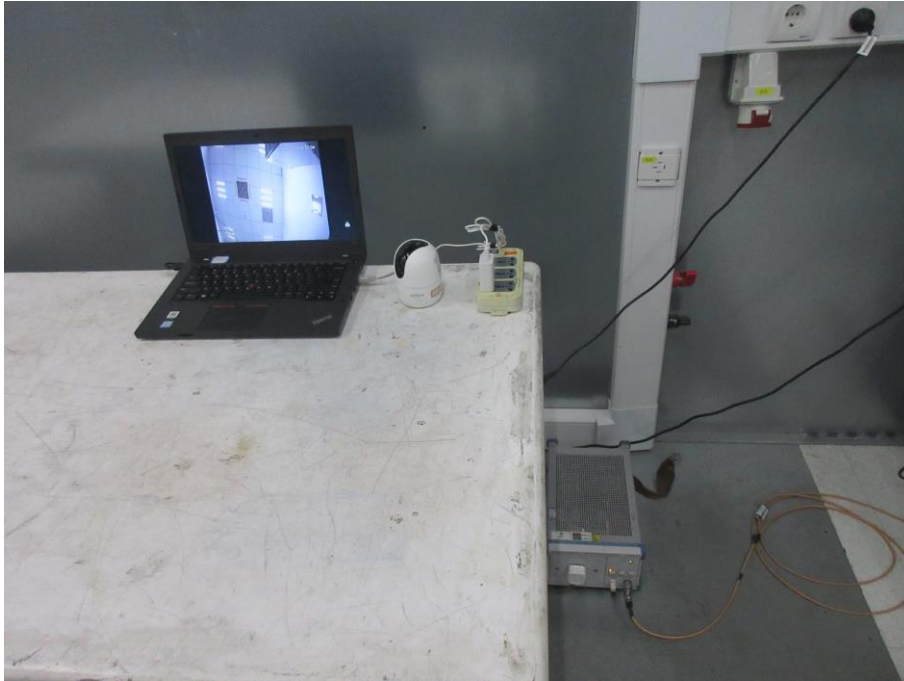

6. Test of Radiated Emission

6.1. Test Limit

The EUT shall meet the limits of below Table when measured at the measuring distance R in accordance with the methods described in European Standard EN 55032. If the reading on the measuring receiver shows fluctuations close to the limit, the reading shall be observed for at least 15 s at each measurement frequency; the highest reading shall be recorded, with the exception of any brief isolated high reading, which shall be ignored.

Table A.4 – Requirements for radiated emissions at frequencies up to 1 GHz for class B equipment

Table clause	Frequency range MHz	Measurement			Class B limits dB(uV/m)
		Facility (see <u>Table A.1</u>)	Distance m	Detector type / bandwidth	
A4.1	30 to 230	OATS/SAC	10	Quasi Peak / 120 kHz	30
	230 to 1000				37
A4.2	30 to 230	OATS/SAC	3		40
	230 to 1000				47
A4.3	30 to 230	FAR	10		32 to 25
	230 to 1000				32
A4.4	30 to 230	FAR	3		42 to 35
	230 to 1000				42

Apply only A4.1 or A4.2 or A4.3 or A4.4 across the entire frequency range.
These requirements are not applicable to the local oscillator and harmonics frequencies of equipment covered by Table A.6.

Table A.5 – Requirements for radiated emissions at frequencies above 1 GHz for class B equipment

Table clause	Frequency range MHz	Measurement			Class B limits dB(uV/m)
		Facility (see <u>Table A.1</u>)	Distance m	Detector type / bandwidth	
A5.1	1000-3000	FSOATS	3	Average / 1 MHz	50
	3000-6000				54
A5.2	1000-3000			Peak / 1 MHz	70
	3000-6000				74

Apply A5.1 and A5.2 across the frequency range from 1 000 MHz to the highest required frequency of measurement derived from Table 1.

6.2. Test Procedures

- a. The EUT was placed on a rotatable table top 0.8 meter above ground.
- b. The EUT was set 3/10 meters from the interference receiving antenna which was mounted on the top of a variable height antenna tower.
- c. The table was rotated 360 degrees to determine the position of the highest radiation.
- d. The antenna is a half wave dipole and its height is varied between one meter and four meters above ground to find the maximum value of the field strength both horizontal polarization and vertical polarization of the antenna are set to make the measurement.
- e. For each suspected emission the EUT was arranged to its worst case and then tune the antenna tower (from 1 M to 4 M) and turn table (from 0 degree to 360 degrees) to find the maximum reading.
- f. Set the test-receiver system to Peak Detect Function and specified bandwidth with Maximum Hold Mode.
- g. If the emission level of the EUT in peak mode was 3 dB lower than the limit specified, then testing will be stopped and peak values of EUT will be reported, otherwise, the emissions which do not have 3 dB margin will be repeated one by one using the quasi-peak method and reported.

6.3. Typical Test Setup

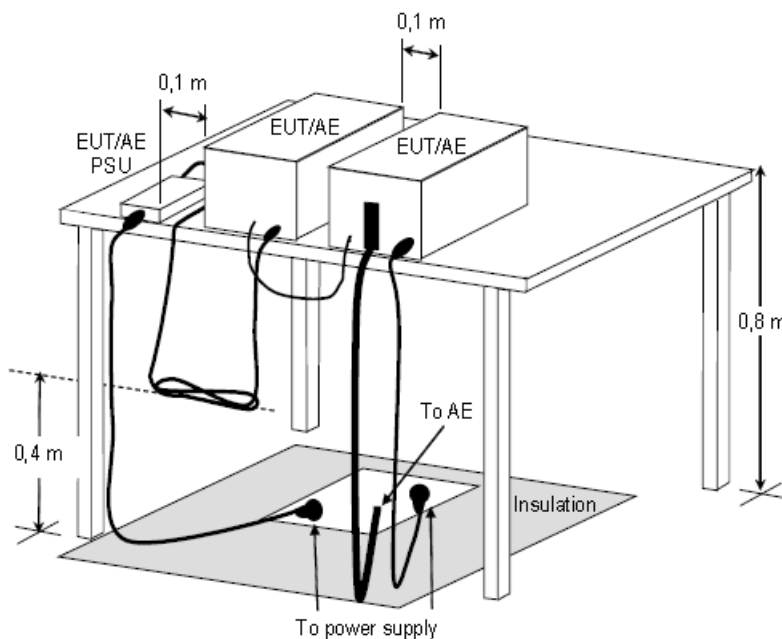

**Figure D.8 – Example measurement arrangement for table-top EUT
(Radiated emission measurement)**

6.4. Measurement Equipment

DESCRIPTION & MANUFACTURER	MODEL NO.	SERIAL NO.	CALIBRATED UNTIL
EMI Test Spectrum ROHDE & SCHWARZ	ESR7	E1R1005	May.11, 2020
Spectrum Analyzer Keysight	N9030B	E1S1003	Aug.03, 2021
Broad-Band Antenna Schwarzbeck	VULB9168	E1A1012	Jul.27, 2021
Double Riaged Vroadband Horn Antenna Schwarzbeck	BBHA9120D	E1A1017	Mar.02, 2021
Preamplifier Agilent	8447D	E1A2001	Apr.19, 2021
Preamplifier Agilent	8449B	E1A2002	Mar.02, 2021

6.5. Test Result and Data (30MHz ~ 1GHz)

Position: Horizontal

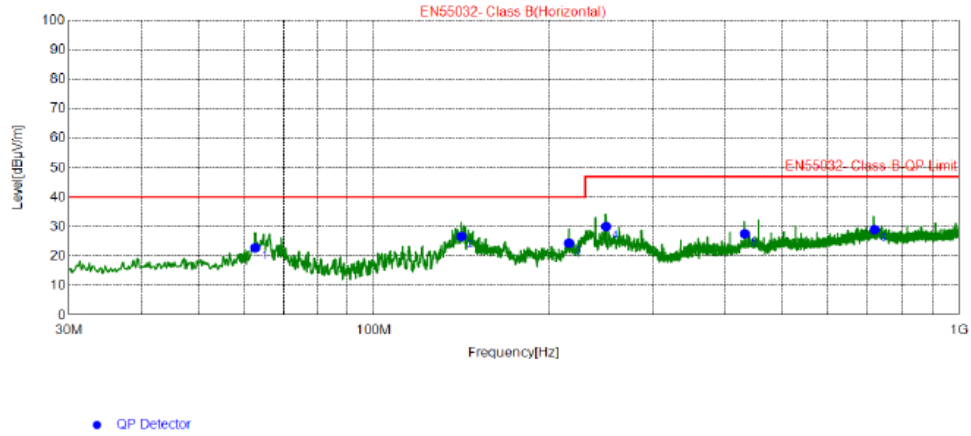

Final Data List									
NO.	Freq. [MHz]	QP Reading [dB µV/m]	Factor [dB]	QP Value [dB µV/m]	QP Limit [dB µV/m]	QP Margin [dB]	Height [cm]	Angle [°]	Polarity
1	62.59	33.63	-10.73	22.90	40.00	17.10	200	187	Horizontal
2	141.1	36.97	-10.29	26.68	40.00	13.32	200	187	Horizontal
3	215.8	36.22	-11.83	24.39	40.00	15.61	200	110	Horizontal
4	249.9	40.67	-10.57	30.10	47.00	16.90	200	318	Horizontal
5	431.9	33.18	-5.55	27.63	47.00	19.37	200	182	Horizontal
6	720.0	30.15	-1.18	28.97	47.00	18.03	200	178	Horizontal

REMARKS:

1. Q.P. is abbreviation of quasi-peak individually.
2. The emission levels of other frequencies were very low against the limit.
3. QP Margin value = QP Limit value – QP value
4. Factor = Antenna Factor + Amplifier Factor + Cable loss
5. QP value = Factor + Reading Value.

Position: Vertical

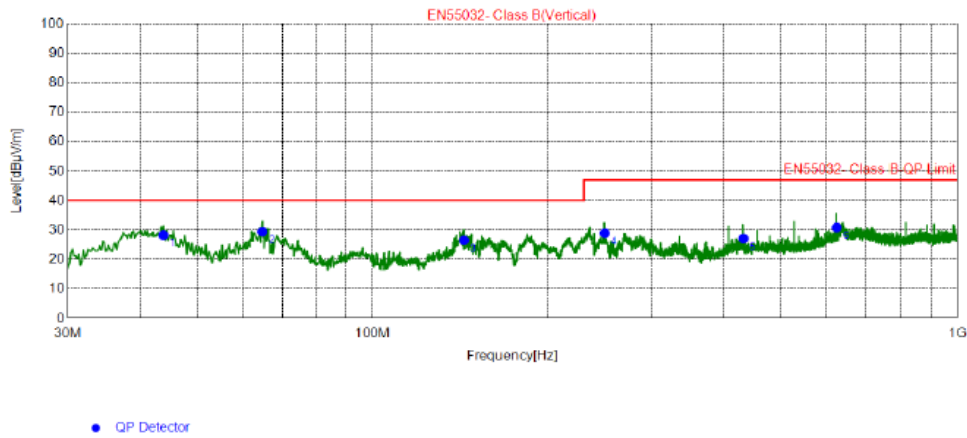

Final Data List									
NO.	Freq. [MHz]	QP Reading [dB µV/m]	Factor [dB]	QP Value [dB µV/m]	QP Limit [dB µV/m]	QP Margin [dB]	Height [cm]	Angle [°]	Polarity
1	43.77	38.45	-10.16	28.29	40.00	11.71	100	322	Vertical
2	64.72	40.54	-11.11	29.43	40.00	10.57	100	241	Vertical
3	143.2	36.72	-10.23	26.49	40.00	13.51	100	155	Vertical
4	249.9	39.48	-10.57	28.91	47.00	18.09	100	227	Vertical
5	431.9	32.67	-5.55	27.12	47.00	19.88	100	182	Vertical
6	624.0	33.13	-2.26	30.87	47.00	16.13	100	250	Vertical

REMARKS:

1. Q.P. is abbreviation of quasi-peak individually.
2. The emission levels of other frequencies were very low against the limit.
3. QP Margin value = QP Limit value – QP value
4. Factor = Antenna Factor + Amplifier Factor + Cable loss
5. QP value = Factor + Reading Value.

6.6. Test Result and Data (1GHz ~ 6GHz)

Position: Horizontal

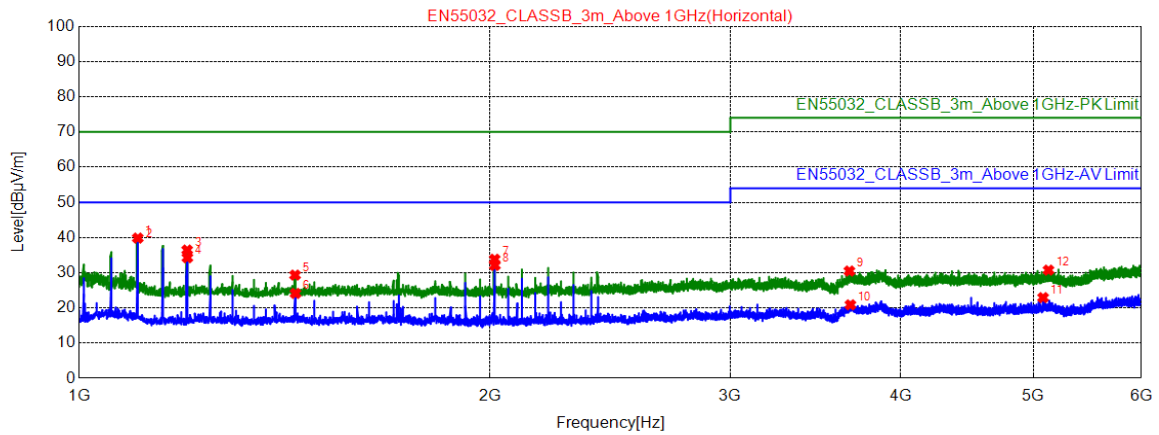

● PK Detector ★ AV Detector

NO.	Freq. [MHz]	Reading [dBµV/m]	Level [dBµV/m]	Limit [dBµV/m]	Margin [dB]	Height [cm]	Angle [°]	Polarity	Detector
1	1104.0000	60.01	39.84	70.00	30.16	100	240	Horizontal	PK
2	1104.5000	59.10	38.93	50.00	11.07	100	240	Horizontal	AV
3	1200.0000	56.29	36.45	70.00	33.55	100	260	Horizontal	PK
4	1200.5000	54.11	34.27	50.00	15.73	100	271	Horizontal	AV
5	1439.5000	48.39	29.33	70.00	40.67	100	94	Horizontal	PK
6	1440.5000	43.18	24.12	50.00	25.88	100	63	Horizontal	AV
7	2016.0000	51.04	33.84	70.00	36.16	100	219	Horizontal	PK
8	2016.5000	49.28	32.08	50.00	17.92	100	219	Horizontal	AV
9	3667.5000	42.64	30.48	74.00	43.52	100	115	Horizontal	PK
10	3673.5000	33.03	20.88	54.00	33.12	100	32	Horizontal	AV
11	5085.0000	33.46	22.93	54.00	31.07	100	229	Horizontal	AV
12	5131.5000	41.13	30.75	74.00	43.25	100	167	Horizontal	PK

REMARKS:

1. The emission levels of other frequencies were very low against the limit.
2. Margin = Limit –Level

Position: Vertical

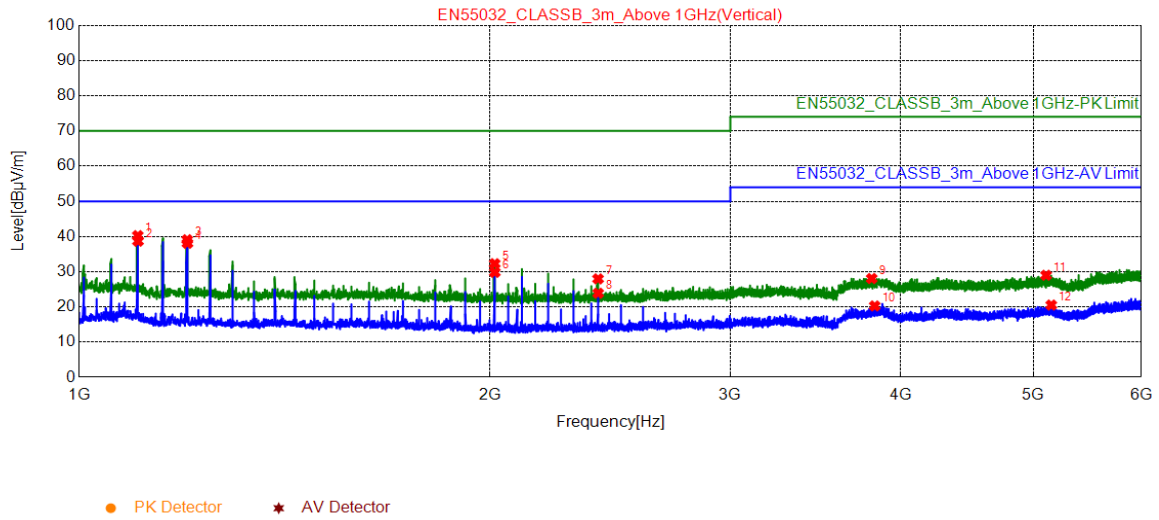

NO.	Freq. [MHz]	Reading [dBµV/m]	Level [dBµV/m]	Limit [dBµV/m]	Margin [dB]	Height [cm]	Angle [°]	Polarity	Detector
1	1104.0000	60.44	40.27	70.00	29.73	100	120	Vertical	PK
2	1104.5000	58.85	38.68	50.00	11.32	100	120	Vertical	AV
3	1200.0000	58.94	39.10	70.00	30.90	100	120	Vertical	PK
4	1200.5000	57.93	38.09	50.00	11.91	100	120	Vertical	AV
5	2016.0000	49.49	32.29	70.00	37.71	100	151	Vertical	PK
6	2016.5000	47.03	29.83	50.00	20.17	100	244	Vertical	AV
7	2400.0000	43.74	27.97	70.00	42.03	100	305	Vertical	PK
8	2400.5000	39.66	23.89	50.00	26.11	100	305	Vertical	AV
9	3808.0000	39.94	28.07	74.00	45.93	100	58	Vertical	PK
10	3827.5000	32.10	20.28	54.00	33.72	100	326	Vertical	AV
11	5111.0000	39.45	29.00	74.00	45.00	100	274	Vertical	PK
12	5155.5000	30.83	20.53	54.00	33.47	100	192	Vertical	AV

REMARKS:

1. The emission levels of other frequencies were very low against the limit.
2. Margin = Limit –Level



**BUREAU
VERITAS**

6.7. Test Photographs (30MHz ~ 1GHz)

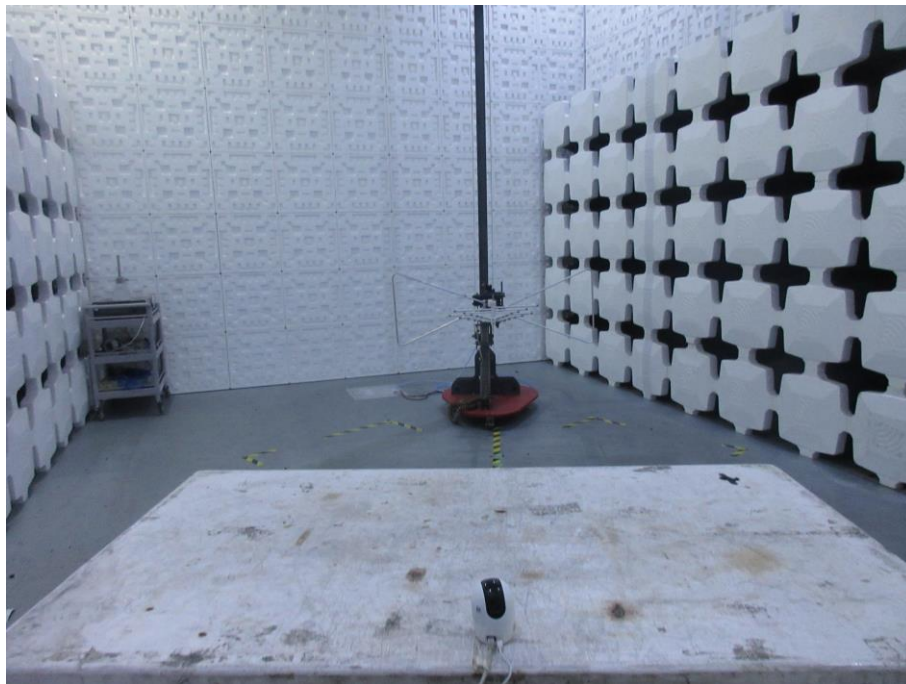

6.8. Test Photographs (1GHz ~ 6GHz)

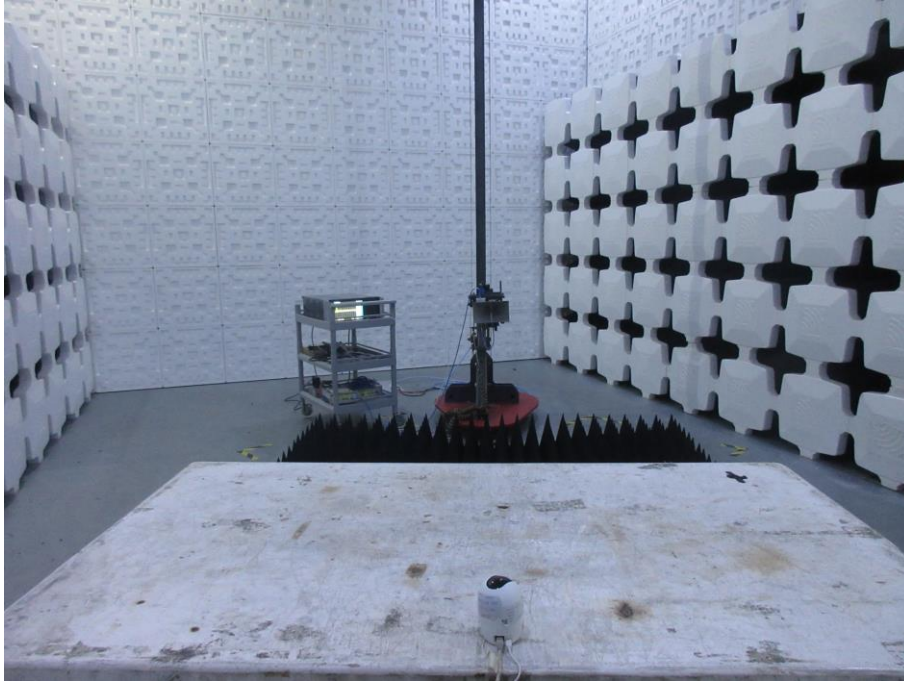

7. Electrostatic Discharge Immunity Test

7.1. Test Procedure

- a. In the case of air discharge testing the climatic conditions shall be within the following ranges:
 - ambient temperature: 15°C to 35°C;
 - relative humidity : 30% to 60%;
 - atmospheric pressure : 86 KPa (860 mbar) to 106 KPa (1060 mbar).
- b. Test programs and software shall be chosen so as to exercise all normal modes of operation of the EUT. The use of special exercising software is encouraged, but permitted only where it can be shown that the EUT is being comprehensively exercised.
- c. The test voltage shall be increased from the minimum to the selected test severity level, in order to determine any threshold of failure. The final severity level should not exceed the product specification value in order to avoid damage to the equipment.
- d. The test shall be performed with both air discharge and contact discharge. On reselected points at least 10 single discharges (in the most sensitive polarity) shall be applied on air discharge. On reselected points at least 25 single discharges (in the most sensitive polarity) shall be applied on contact discharge.
- e. For the time interval between successive single discharges an initial value of one second is recommended. Longer intervals may be necessary to determine whether a system failure has occurred.
- f. In the case of contact discharges, the tip of the discharge electrode shall touch the EUT before the discharge switch is operated.
- g. In the case of painted surface covering a conducting substrate, the following procedure shall be adopted :
 - If the coating is not declared to be an insulating coating by the equipment manufacturer, then the pointed tip of the generator shall penetrate the coating so as to make contact with the conducting substrate.
 - Coating declared as insulating by the manufacturer shall only be submitted to the air discharge.
 - The contact discharge test shall not be applied to such surfaces.
- h. In the case of air discharges, the round discharge tip of the discharge electrode shall be approached as fast as possible (without causing mechanical damage) to touch the EUT . After each discharge, the ESD generator (discharge electrode) shall be removed from the EUT. The generator is then retriggered for a new single discharge. This procedure shall be repeated until the discharges are completed. In the case of an air discharge test, the discharge switch, which is used for contact discharge, shall be closed.

7.2. Test Setup for Tests Performed in Laboratory

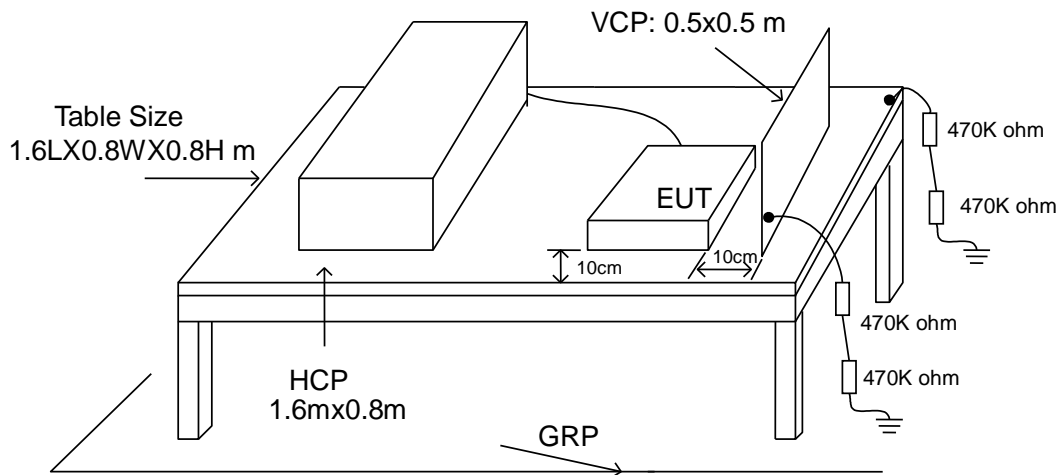

The test setup consists of the test generator, EUT and auxiliary instrumentation necessary to perform DIRECT and INDIRECT application of discharges to the EUT as applicable, in the follow manner :

- a. Contact Discharge to the conductive surfaces and to coupling plane;
- b. Air Discharge at insulating surfaces.

The preferred test method is that of type tests performed in laboratories and the only accepted method of demonstrating conformance with this standard. The EUT was arranged as closely as possible to arrangement in final installed conditions.

A ground reference plane was provided on the floor of the test site. It was a metallic sheet (copper or aluminum) of 0.25 mm, minimum thickness; other metallic may be used but they shall have at least 0.65 mm thickness. We provided 1 mm thickness stainless steel ground reference plane. The minimum size of the ground reference plane is 2.5 m x 2.5 m, the exact size depending on the dimensions of the EUT. It was connected to the protective grounding system.

The EUT was arranged and connected according to its functional requirements. A distance of 1m minimum was provided between the EUT and the wall of the lab and any other metallic structure. In cases where this length exceeds the length necessary to apply the discharges to the selected points, the excess length shall, where possible, be placed non-inductively off the ground reference plane and shall not come closer than 0.2m to other conductive parts in the test setup.

Where the EUT is installed on a metal table, the table was connected to the reference plane via a cable with a 470k ohm resistor located at each end, to prevent a build-up of charge. The test setup was consist a wooden table, 0.8m high, standing on the ground reference plane. A HCP, 1.6 m x 0.8 m, was placed on the table. The EUT and cables was isolated from the HCP by an insulating support 0.5 mm thick. The VCP size, 0.5 m x 0.5 m.

7.3. Test Severity Levels

Contact Discharge		Air Discharge	
Level	Test Voltage (KV) of Contact discharge	Level	Test Voltage (KV) of Air Discharge
1	±2	1	±2
2	±4	2	±4
3	±6	3	±8
4	±8	4	±15
X	Specified	X	Specified

Remark: "X" is an open level.

7.4. Measurement Equipment

DESCRIPTION & MANUFACTURER	MODEL NO.	SERIAL NO.	CALIBRATED UNTIL
Electrostatic discharge simulator and GUN &Noiseken	ESS-2002EX TC-815R	E1ES016	Oct.30, 2020

7.5. Test Result and Data

Final Test Result	: PASS
Pass performance criteria	: A
Required performance criteria	: B
Basic Standard	: EN 61000-4-2
Product Standard	: EN 50130-4, EN 55024, EN 55035
Test Voltage	: $\pm 2 / \pm 4 / \pm 8$ kV for air discharge, : $\pm 2 / \pm 4 / \pm 6$ kV for contact discharge
Temperature	: 22°C
Relative Humidity	: 48 %
Atmospheric Pressure	: 101 kPa

For EN 50130-4

	Contact Discharge								Air Discharge							
	10 times / each								10 times / each							
Voltage	2 kV		4 kV		6 kV		8 kV		2 kV		4 kV		8 kV		10 kV	
Point\Polarity	+	-	+	-	+	-	+	-	+	-	+	-	+	-	+	-
HCP	A	A	A	A	A	A	---	---	---	---	---	---	---	---	---	---
VCP	A	A	A	A	A	A	---	---	---	---	---	---	---	---	---	---
All metal portion	A	A	A	A	A	A	---	---	---	---	---	---	---	---	---	---
All nonmetal portion	---	---	---	---	---	---	---	---	A	A	A	A	A	A	---	---

For EN 55024

	Contact Discharge								Air Discharge							
	25 times / each								10 times / each							
Voltage	2 kV		4 kV		6 kV		8 kV		2 kV		4 kV		8 kV		10 kV	
Point\Polarity	+	-	+	-	+	-	+	-	+	-	+	-	+	-	+	-
HCP	A	A	A	A	A	A	---	---	---	---	---	---	---	---	---	---
VCP	A	A	A	A	A	A	---	---	---	---	---	---	---	---	---	---
All metal portion	A	A	A	A	A	A	---	---	---	---	---	---	---	---	---	---
All nonmetal portion	---	---	---	---	---	---	---	---	A	A	A	A	A	A	---	---

For EN 55035

	Contact Discharge								Air Discharge							
	10 times / each								10 times / each							
Voltage	2 kV		4 kV		6 kV		8 kV		2 kV		4 kV		8 kV		10 kV	
Point\Polarity	+	-	+	-	+	-	+	-	+	-	+	-	+	-	+	-
HCP	A	A	A	A	A	A	---	---	---	---	---	---	---	---	---	---
VCP	A	A	A	A	A	A	---	---	---	---	---	---	---	---	---	---
All metal portion	A	A	A	A	A	A	---	---	---	---	---	---	---	---	---	---
All nonmetal portion	---	---	---	---	---	---	---	---	A	A	A	A	A	A	---	---

7.6. Test Photographs



8. Radio Frequency electromagnetic field immunity test

8.1. Test Procedure

- a. The equipment to be tested is placed in the center of the enclosure on a wooden table. The equipment is then connected to power and signal leads according to pertinent installation instructions.
- b. The antenna which is enabling the complete frequency range of 80-1000 MHz is placed 3m away from the equipment. The required field strength is determined by placing the field strength meter(s) on top of or directly alongside the equipment under test and monitoring the field strength meter via a remote field strength indicator outside the enclosure while adjusting the continuous-wave to the applicable antennae.
- c. The test is normally performed with the antenna facing the most sensitive side of the EUT. The polarization of the field generated by the bucolical antenna necessitates testing each position twice, once with the antenna positioned vertically and again with the antenna positioned horizontally. The circular polarization of the field from the log-spiral antenna makes a change of position of the antenna unnecessary.
- d. At each of the above conditions, the frequency range is swept 80-1000 MHz, pausing to adjust the R.F. signal level or to switch oscillators and antenna. The rate of sweep is in the order of $1.5 \cdot 10^{-3}$ decades/s. The sensitive frequencies or frequencies of dominant interest may be discretely analyzed.

8.2. Test Severity Levels

Frequency Band : 80-1000 MHz	
Level	Test field strength (V/m)
1	1
2	3
3	10
X	Specified
Remark: "X" is an open class.	

8.3. TEST SETUP

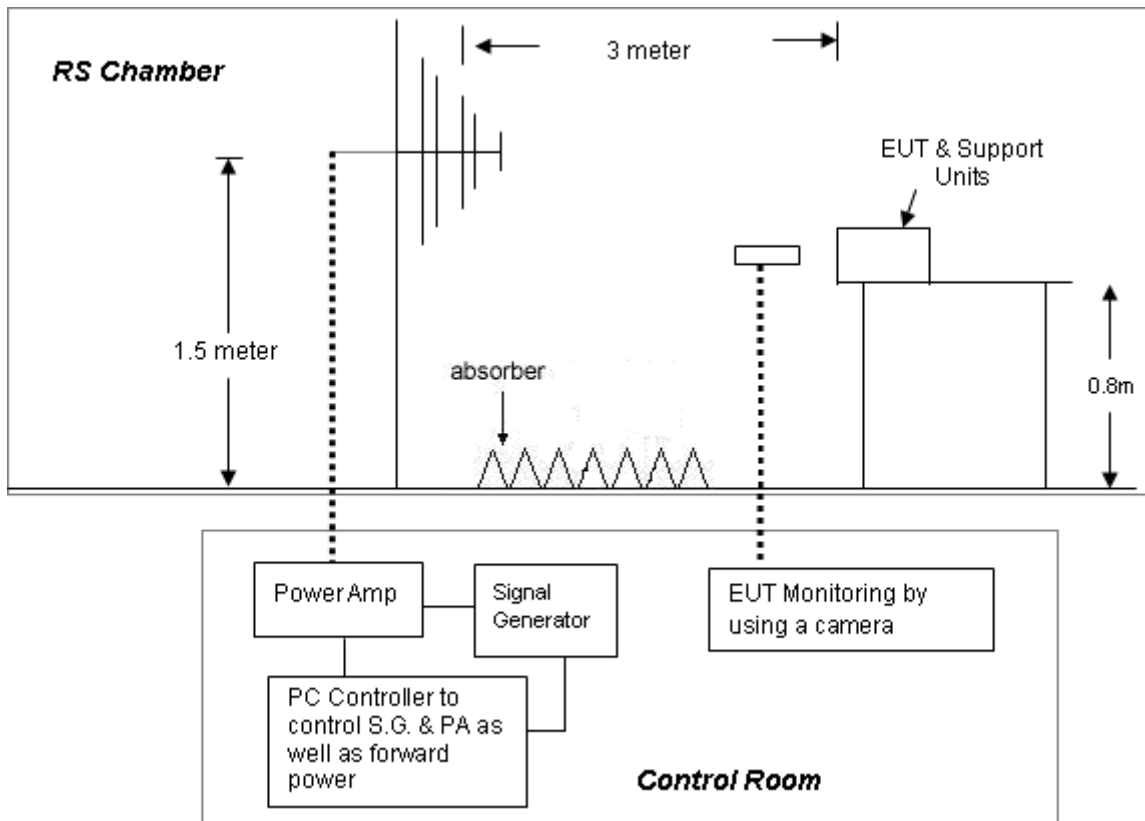

- For the actual test configuration, please refer to the related item – Photographs of the Test Configuration.

NOTE:

TABLETOP EQUIPMENT

The EUT installed in a representative system as described in section 7 of IEC 61000-4-3 was placed on a non-conductive table 0.8 meters in height. The system under test was connected to the power and signal wire according to relevant installation instructions.

FLOOR STANDING EQUIPMENT

The EUT installed in a representative system as described in section 7 of IEC 61000-4-3 was placed on a non-conductive wood support 0.1 meters in height. The system under test was connected to the power and signal wire according to relevant installation instructions.

8.4. Measurement Equipment

DESCRIPTION & MANUFACTURER	MODEL NO.	SERIAL NO.	CALIBRATED UNTIL
Signal Generator ANRITSU	MG3692B	E1S9006	Mar.02, 2021
BiconiLog Antenna SCHWARZBECK	VULP 9118 E	E1A1037	N/A
High Gain Horn Antenna SCHWARZBECK	STLP 9149	E1A1038	N/A
RF Power Amplifier MILMEGA	80RF 1000-75	E1P4004	Apr.19, 2021
RF Power Amplifier MILMEGA	AS0102-65	E1P4005	Apr.19, 2021
RF Power Amplifier MILMEGA	AS1860-50	E1P4006	Apr.19, 2021
Power Meter	4232A/51011	E1P5001	Apr.19, 2021
Software	TOYO	N/A	N/A

8.5. Test Result and Data

Final Test Result	: PASS
Pass performance criteria	: A
Required performance criteria	: A
Basic Standard	: EN 61000-4-3
Product Standard	: EN 50130-4, EN 55024, EN 55035
Frequency Range	: 80~2700 MHz
Temperature	: 22°C
Relative Humidity	: 48%
Atmospheric Pressure	: 101 kPa

For EN 50130-4

1. Modulation : AM 80% , 1KHz sine wave, Dwell time: 3 S				
2. Modulation : PM 1Hz(0.5s ON, 0.5s OFF), Dwell time: 3 S				
Frequency Step Size : 1 % of preceding frequency value				
Frequency (MHz)	Antenna Polarization	face	Field strength (V/m)	Result
80~2700	Vertical	Front	10 V/m	A
80~2700	Vertical	Rear	10 V/m	A
80~2700	Vertical	Left	10 V/m	A
80~2700	Vertical	Right	10 V/m	A
80~2700	Horizontal	Front	10 V/m	A
80~2700	Horizontal	Rear	10 V/m	A
80~2700	Horizontal	Left	10 V/m	A
80~2700	Horizontal	Right	10 V/m	A

For EN 55024

1. Modulation : AM 80% , 1KHz sine wave, Dwell time: 3 S				
Frequency Step Size : 1 % of preceding frequency value				
Frequency (MHz)	Antenna Polarization	face	Field strength (V/m)	Result
80~1000	Vertical	Front	3 V/m	A
80~1000	Vertical	Rear	3 V/m	A
80~1000	Vertical	Left	3 V/m	A
80~1000	Vertical	Right	3 V/m	A
80~1000	Horizontal	Front	3 V/m	A
80~1000	Horizontal	Rear	3 V/m	A
80~1000	Horizontal	Left	3 V/m	A
80~1000	Horizontal	Right	3 V/m	A

For EN 55035

1. Modulation : AM 80% , 1KHz sine wave, Dwell time: 3 S Frequency Step Size : 1 % of preceding frequency value				
Frequency (MHz)	Antenna Polarization	face	Field strength (V/m)	Result
80~1000, 1800, 2600, 3500, 5000	Vertical	Front	3 V/m	A
80~1000, 1800, 2600, 3500, 5000	Vertical	Rear	3 V/m	A
80~1000, 1800, 2600, 3500, 5000	Vertical	Left	3 V/m	A
80~1000, 1800, 2600, 3500, 5000	Vertical	Right	3 V/m	A
80~1000, 1800, 2600, 3500, 5000	Horizontal	Front	3 V/m	A
80~1000, 1800, 2600, 3500, 5000	Horizontal	Rear	3 V/m	A
80~1000, 1800, 2600, 3500, 5000	Horizontal	Left	3 V/m	A
80~1000, 1800, 2600, 3500, 5000	Horizontal	Right	3 V/m	A

8.6. Test Photographs

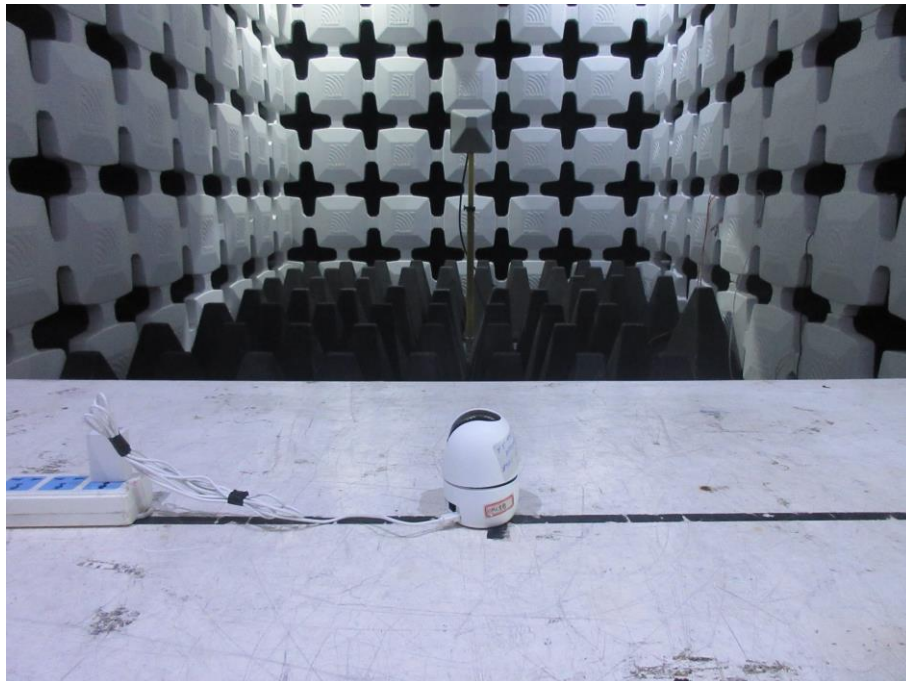
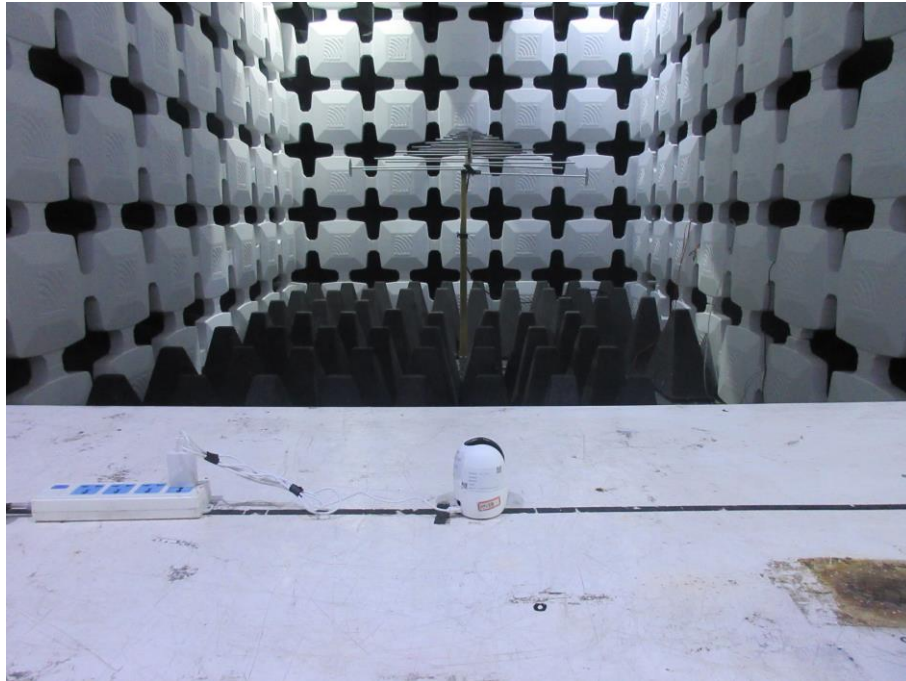

9. Electrical Fast Transient/ Burst Immunity Test

9.1. Test Procedure

- a. In order to minimize the effect of environmental parameters on test results, the climatic conditions when test is carrying out shall comply with the following requirements:
 - ambient temperature: 15°C to 35°C;
 - relative humidity : 45% to 75%;
 - Atmospheric pressure: 86 Kpa (860 mbar) to 106 Kpa (1060 mbar).
- b. In order to minimize the effect of environmental parameters on test results, the electromagnetic environment of the laboratory shall not influence the test results.
- c. The variety and diversity of equipment and systems to be tested make it difficult to establish general criteria for the evaluation of the effects of fast transients/bursts on equipment and systems.
- d. Test on Power Line:
 - The EFT/B-generator was located on the GRP.
For floor standing equipment 1,0 m
For table top equipment 0,5 m
 - The EFT/B-generator provides the ability to apply the test voltage in a non-symmetrical condition to the power supply input terminals of the EUT.
- e. Test on Communication Lines
 - The coupling clamp is composed of a clamp unit for housing the cable (length more than 3 m), and was placed on the GRP.
 - The coupling clamp provides the ability of coupling the fast transient/bursts to the cable under test.
- f. The test results may be classified on the basic of the operating conditions and the functional specification of the equipment under test, according to the following performance criteria :
 - Normal performance within the specification limits.
 - Temporary degradation or loss of function or performance which is self-recoverable.
 - Temporary degradation or loss of function or performance which requires operator intervention or system reset.
 - Degradation or loss of function which is not recoverable due to damage of equipment (components).

9.2. Test Severity Levels

The following test severity levels are recommended for the fast transient/burst test :

Open circuit output test voltage $\pm 10\%$		
Level	On Power Supply	On I/O signal, data and control line
1	0.5 kV	0.25 kV
2	1.0 kV	0.50 kV
3	2.0 kV	1.00 kV
4	4.0 kV	2.00 kV
X	Specified	Specified

Remark : “ X ” is an open level. The level is subject to negotiation between the user and manufacturer or is specified by the manufacturer.

9.3. TEST SETUP

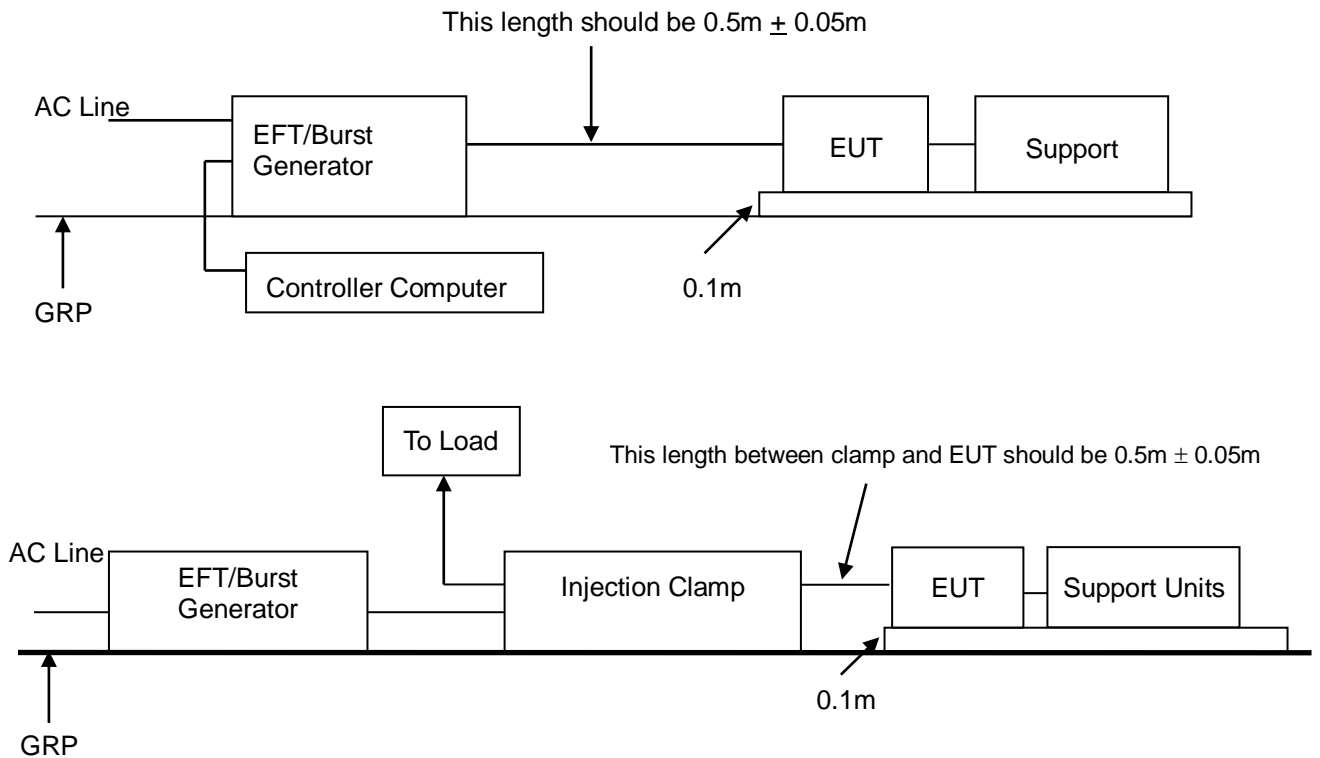

- For the actual test configuration, please refer to the related item – Photographs of the Test Configuration.

NOTE:

TABLETOP EQUIPMENT

The configuration consisted of a wooden table (0.1m high) standing on the Ground Reference Plane. The GRP consisted of a sheet of aluminum (at least 0.25mm thick and 2.5m square) connected to the protective grounding system. A minimum distance of 0.5m was provided between the EUT and the walls of the laboratory or any other metallic structure.

FLOOR STANDING EQUIPMENT

The EUT installed in a representative system as described in section 7 of IEC 61000-4-4 and its cables, were isolated from the Ground Reference Plane by an insulating support that is 0.1-meter thick. The GRP consisted of a sheet of aluminum (at least 0.25mm thick and 2.5m square) connected to the protective grounding system.

9.4. Measurement Equipment

DESCRIPTION & MANUFACTURER	MODEL NO.	SERIAL NO.	CALIBRATED UNTIL
EMC Test System &Teseq	NSG3060	E1ES021	Mar.03, 2021
Capacitor Clamp	SYS014	E1C3001	Apr.19, 2021

9.5. Test Result and Data

Final Test Result	: PASS
Pass performance criteria	: A
Required performance criteria	: B
Basic Standard	: EN 61000-4-4
Product Standard	: EN 50130-4, EN 55024, EN 55035
Test Voltage	: On Power Supply -- ± 0.5 kV, ± 1.0 kV, ± 2.0 kV On Signal Port -- ± 0.5 kV, ± 1.0 kV
Temperature	: 22 °C
Relative Humidity	: 48%
Atmospheric Pressure	: 101 kPa

For EN 50130-4

Pulse : 5/50 ns	Repetition Rate: <u>100kHz</u>			
Burst : 15ms/300ms				
Test time : 1 min/each condition				
Voltage/ Mode/ Polarity/ Result/ Phase	<u>1.0 kV</u>		<u>2.0 kV</u>	
	+	-	+	-
Power Line	---	---	A	A
Signal Line	A	A	---	---

For EN 55024

Pulse : 5/50 ns	Repetition Rate: <u>5kHz</u>			
Burst : 15ms/300ms				
Test time : 1 min/each condition				
Voltage/ Mode/ Polarity/ Result/ Phase	<u>0.5 kV</u>		<u>1.0 kV</u>	
	+	-	+	-
Power Line	---	---	A	A
Signal Line	A	A	---	---

For EN 55035

Pulse : 5/50 ns	Repetition Rate: <u>5kHz</u>			
Burst : 15ms/300ms				
Test time : 1 min/each condition				
Voltage/ Mode/ Polarity/ Result/ Phase	<u>0.5 kV</u>		<u>1.0 kV</u>	
	+	-	+	-
Power Line	---	---	A	A
Signal Line	A	A	---	---

9.6. Test Photographs



10. Surge Immunity Test

10.1. Test Procedure

- a. Climatic conditions
The climatic conditions shall comply with the following requirements :
 - ambient temperature : 15 °C to 35 °C
 - relative humidity : 10 % to 75 %
 - atmospheric pressure : 86 kPa to 106 kPa (860 mbar to 1060 mbar)
- b. Electromagnetic conditions
the electromagnetic environment of the laboratory shall not influence the test results.
- c. The test shall be performed according the test plan that shall specify the test set-up with
 - generator and other equipment utilized;
 - test level (voltage/current);
 - generator source impedance;
 - internal or external generator trigger;
 - number of tests : at least five positive and five negative at the selected points;
 - repetition rate : maximum 1/min.
 - inputs and outputs to be tested;
 - representative operating conditions of the EUT;
 - sequence of application of the surge to the circuit;
 - phase angle in the case of AC. power supply;
 - actual installation conditions, for example :
 - AC : neutral earthed,
 - DC : (+) or (-) earthed to simulated the actual earthing conditions.
- d. If not otherwise specified the surges have to be applied synchronized to the voltage phase at the zero-crossing and the peak value of the AC. voltage wave (positive and negative).
- e. The surges have to be applied line to line and line(s) and earth. When testing line to earth, the test voltage has to be applied successively between each of the lines and earth, if there is no other specification.
- f. The test procedure shall also consider the non-linear current-voltage characteristics of the equipment under test. Therefore the test voltage has to be increased by steps up to the test level specified in the product standard or test plan.
- g. All lower levels including the selected test level shall be satisfied. For testing the secondary protection, the output voltage of the generator shall be increased up to the worst-case voltage breakdown level (let-through level) of the primary protection.
- h. If the actual operating signal sources are not available, that may be simulated. Under no circumstances may the test level exceed the product specification. The test shall be carried out according to a test plan.
- i. To find all critical points of the duty cycle of the equipment, a sufficient number of positive and negative test pulses shall be applied. For acceptance test previously unstressed equipment shall be used to the protection devices shall be replaced.

10.2. Test Severity Level

Level	Open-circuit test voltage, $\pm 10\%$, KV
1	0.5
2	1.0
3	2.0
4	4.0
X	Specified

NOTE: "X" is an open class. This level can be specified in the product specification.

10.3. TEST SETUP

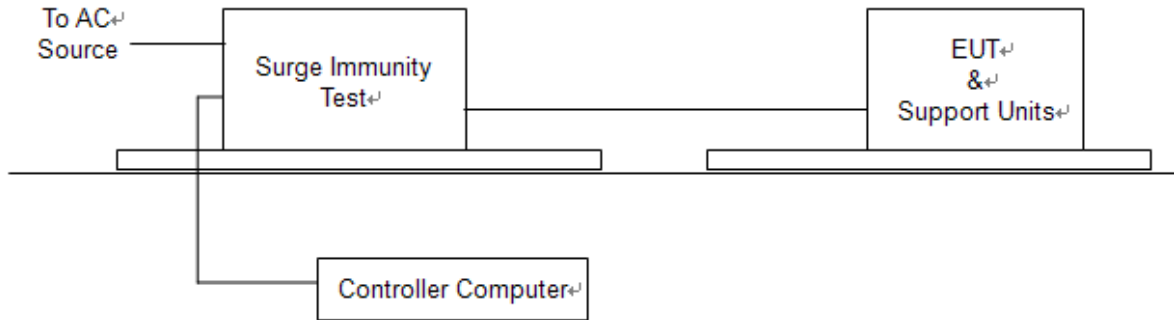

For the actual test configuration, please refer to the related item – Photographs of the Test Configuration.

10.4. Measurement Equipment

DESCRIPTION & MANUFACTURER	MODEL NO.	SERIAL NO.	CALIBRATED UNTIL
EMC Test System &Teseq	NSG3060	E1ES021	Mar.03, 2021

10.5. Test Result and Data

Final Test Result	: PASS
Pass performance criteria	: A
Required performance criteria	: B
Basic Standard	: EN 61000-4-5
Product Standard	: EN 50130-4, EN 55024, EN 55035
Test Voltage	: Power Port -- ± 0.5 kV, ± 1.0 kV Signal Port -- ± 0.5 kV, ± 1.0 kV
Temperature	: 22°C
Relative Humidity	: 48%
Atmospheric Pressure	: 101 kPa

For EN 50130-4

Waveform : 1.2/50 μ s(8/20 μ s) Repetition rate : 60 sec						
Time : 20 time/each condition for power port, 5 time/each condition for signal port						
Phase Voltage / Mode / Polarity / Result			0°	90°	180°	270°
<u>1.0kV</u>	L-N	+	A	A	A	A
		-	A	A	A	A
<u>1.0kV</u>	Signal port	+	A			
		-				

For EN 55024

Waveform : 1.2/50 μ s(8/20 μ s) Repetition rate : 60 sec						
Time : 20 time/each condition for power port, 5 time/each condition for signal port						
Phase Voltage / Mode / Polarity / Result			0°	90°	180°	270°
<u>1.0kV</u>	L-N	+	A	A	A	A
		-	A	A	A	A
<u>1.0kV</u>	Signal port	+	A			
		-				

For EN 55035

Waveform : 1.2/50 μ s(8/20 μ s) Repetition rate : 60 sec						
Time : 20 time/each condition for power port, 5 time/each condition for signal port						
Phase Voltage / Mode / Polarity / Result			0°	90°	180°	270°
<u>1.0kV</u>	L-N	+	A	A	A	A
		-	A	A	A	A
<u>1.0kV</u>	Signal port	+	A			
		-				

10.6. Test Photographs



11. Conduction Disturbances induced by Radio-Frequency Fields

11.1. Test Procedure

- a. The EUT shall be operated within its intended climatic conditions. The temperature and relative humidity should be recorded.
- b. This test method test can be performed without using a sell shielded enclosure. This is because the disturbance levels applied and the geometry of the setups are not likely to radiated a high amount of energy, especially at the lower frequencies. If under certain circumstances the radiated energy is too high, a shielded enclosure has to be used.
- c. The test shall be performed with the test generator connected to each of the coupling and decoupling devices in turn while the other non-excited RF-input ports of the coupling devices are terminated by a 50 ohm load resistor.
- d. The frequency range is swept from 150 KHz to 80 MHz, using the signal levels established during the setting process, and with the disturbance signal 80% amplitude modulated with a 1KHz sign wave, pausing to adjust the RF-signal level or to switch coupling devices as necessary. The rate of sweep shall no exceed 1.5×10^{-3} decades/s. Where the frequency is swept incrementally, the step size shall no exceed 1% of the start and thereafter 1% of the preceding frequency value.
- e. The dwell time at each frequency shall not be less than the time necessary for the EUT to be exercised, and able to respond. Sensitive frequencies e.g. clock frequency (ies) and harmonics or frequencies of dominant interest shall be analyzed separately.
- f. An alternative test procedure may be adopted, wherein the frequency range is swept incrementally, with a step size not exceeding 4% of the start ad thereafter 4% of the preceding frequency value. The test level should be at least twice the value of the specified test level.
- g. In cases of dispute, the test procedure using a step size not exceeding 1% of the start and thereafter 1% of preceding frequency value shall take precedence.
- h. Attempts should be made to fully exercise the EUT during testing, and to fully interrogate all exercise modes selected for susceptibility.
- i. The use of special exercising programs is recommended.
- j. Testing shall be performed according to a Test Plan, which shall be included in the test report.
- k. It may be necessary to carry out some investigatory testing in order to establish some aspects of the test plan.

11.2. Test Severity Levels

Level	Voltage Level (e.m.f.)
1	1 V
2	3 V
3	10 V
x	Specified
NOTE - x is an open class. This level can be specified in the product specification.	

11.3. TEST SETUP

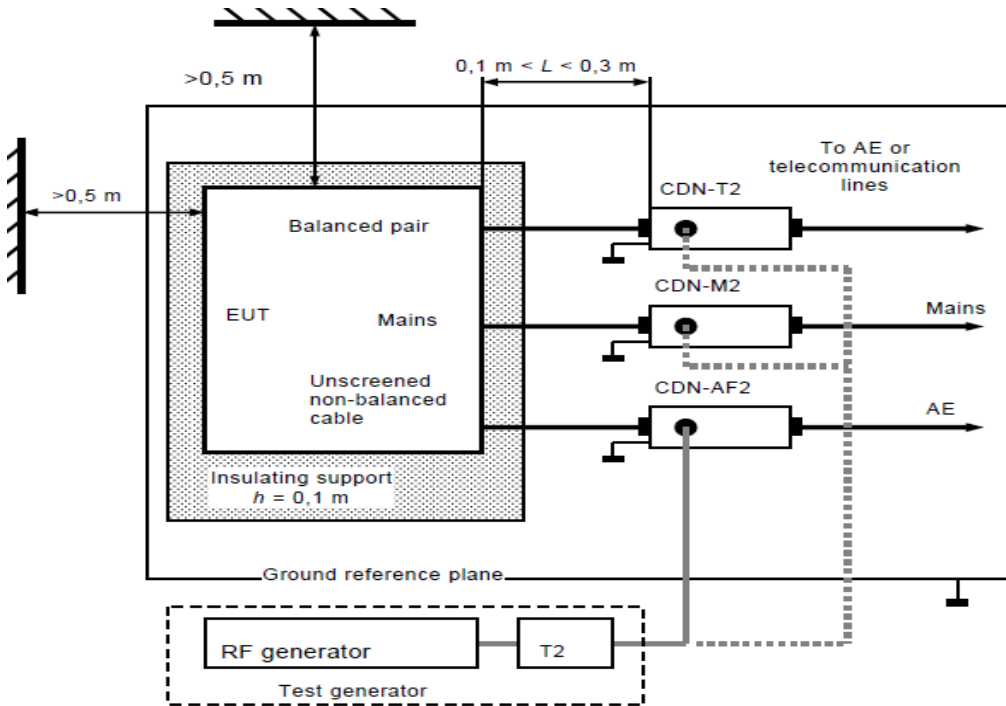

- Note:**
1. The EUT is setup 0.1m above Ground Reference Plane
 2. The CDNs and / or EM clamp used for real test depends on ports and cables configuration of EUT.
 3. For the actual test configuration, please refer to the related item – Photographs of the Test Configuration.

11.4. Measurement Equipment

DESCRIPTION & MANUFACTURER	MODEL NO.	SERIAL NO.	CALIBRATED UNTIL
Compact RF Simulator Teseq	NSG 4070-30	E1ES017	Apr.19, 2020
Coupling-Decoupling Network Lüthi Elektronik-Feinmechnik	CDN L-801 M2/M3	E1C4003	Apr.19, 2020
Electromagnetic Injection Clamp Teseq	EM101	E1C3008	Mar.29, 2021

11.5. Test Result and Data

Final Test Result	: PASS
Pass performance criteria	: A
Required performance criteria	: A
Basic Standard	: EN 61000-4-6
Product Standard	: EN 50130-4, EN 55024, EN 55035
Coupling mode	: CDN-(M2/M3) for power ports EM-CLAMP for Signal Ports
Temperature	: 22 °C
Relative Humidity	: 48%
Atmospheric Pressure	: 101 kPa

For EN 50130-4

Frequency : 0.15~100MHz, Modulation : AM 80%,1KHz sine wave and PM 1Hz (0.5s ON, 0.5s OFF) Dwell time:3.0s Frequency Step Size : 1 % of preceding frequency value			
Frequency	Test mode	Voltage(V)	Result
0.15 ~ 100MHz	Power port	10	A
0.15 ~ 100MHz	Signal port	10	A

For EN 55024

Frequency : 0.15~80MHz, Modulation : AM 80%,1KHz sine wave, Dwell time:3.0s Frequency Step Size : 1 % of preceding frequency value			
Frequency	Test mode	Voltage(V)	Result
0.15 ~ 80MHz	Power port	3	A
0.15 ~ 80MHz	Signal port	3	A

For EN 55035

Frequency : 0.15~80MHz, Modulation : AM 80%,1KHz sine wave Dwell time:3.0s			
Frequency Step Size : 1 % of preceding frequency value			
Frequency	Test mode	Voltage(V)	Result
0.15 ~ 10MHz	Power port and signal port	3	A
10 ~ 30MHz	Power port and signal port	3 ~ 1	A
30 ~ 80MHz	Power port and signal port	1	A

11.6. Test Photographs



12. Power Frequency Magnetic Field Immunity Test

12.1. Test Setup

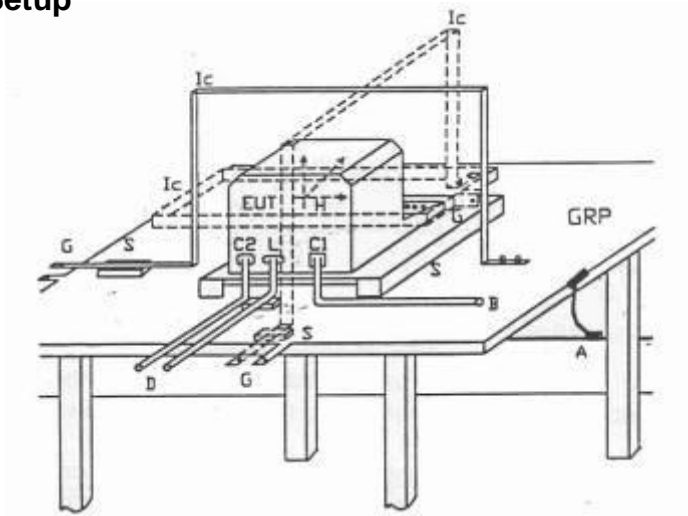

GPR	: Ground plane	C1	: Power supply circuit
A	: Safety earth	C2	: Signal circuit
S	: Insulating support	L	: Communication line
EUT	: Equipment under test	B	: To power supply source
Lc	: Induction coil	D	: To signal source, simulator
E	: Earth terminal	G	: To the test generator

12.2. Test Severity Levels

Level	Magnetic field strength (A/m)
1	1
2	3
3	10
4	30
5	100
X ¹⁾	special

NOTE 1 "X" is an open level. This level can be given in the product specification.



12.3.Measurement Equipment

DESCRIPTION & MANUFACTURER	MODEL NO.	SERIAL NO.	CALIBRATED UNTIL
Signal Conditioning Unit- Lumped Impedance Schaffner	CCN 100-1	E1HF002	Apr.19, 2021
5KV AC Power Source Schaffner	NSG 1007	E1HF001	Apr.19, 2021
Field coil	INA 703 coil	E1M 6002	N/A
Software	Shchaffner Win 2100V3	N/A	N/A

12.4. Test Result and Data

Final Test Result : **PASS**
 Pass performance criteria : A
 Required performance criteria : A
 Basic Standard : EN 61000-4-8
 Product Standard : EN 55024, EN 55035
 Temperature : 22°C
 Relative Humidity : 48%
 Atmospheric Pressure : 101 kPa

For EN 55024

Power Frequency Magnetic Field : <u>50/60</u> Hz, <u>1</u> A/m		
Coil Orientation	Testing duration	Results
X-axis	1.0 Min	A
Y-axis	1.0 Min	A
Z-axis	1.0 Min	A

For EN 55035

Power Frequency Magnetic Field : <u>50/60</u> Hz, <u>1</u> A/m		
Coil Orientation	Testing duration	Results
X-axis	1.0 Min	A
Y-axis	1.0 Min	A
Z-axis	1.0 Min	A

12.5. Test Photographs



13. Voltage Dips and Voltage Interruptions Immunity Test Setup

13.1. Test Conditions

1. Source voltage and frequency : AC 100/230/240V / 50Hz, Single phase.
2. Test of interval : 10 sec.
3. Level and duration : Sequence of 3 dips/interrupts.
4. Voltage rise (and fall) time : 1 ~ 5 μ s.
5. Test severity :

Voltage dips and Interrupt reduction (%)	Test Duration (period)
>95%	250
30%	25
>95%	0.5

13.2. TEST SETUP

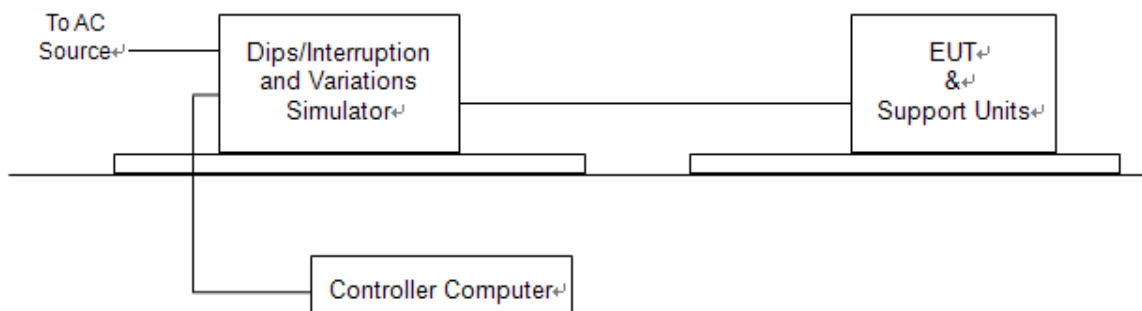

For the actual test configuration, please refer to the related item – Photographs of the Test Configuration.

13.3. Measurement Equipment

DESCRIPTION & MANUFACTURER	MODEL NO.	SERIAL NO.	CALIBRATED UNTIL
Power Fail Simulator	PFS 503N	E1HF003	Mar.03, 2021
Power Source	NetWave	S1S1022	Mar.03, 2021

13.4. Test Result and Data

Final Test Result : **PASS**
 Pass performance Criteria : C for voltage interruption, A for voltage dips,
 Required performance Criteria : C for voltage interruption, B/C for voltage dips
 Basic Standard : EN 61000-4-11
 Product Standard : EN 50130-4 and EN 55024
 Temperature : 22°C
 Relative Humidity : 48%
 Atmospheric Pressure : 101 kPa

For EN 50130-4

Voltage(UT): AC 230 V 50 Hz Interval(s) : 10s Times : 3										
Test mod	Test level UT %	Durations (period / ms)	Phase / Result							
			0	45	90	135	180	225	270	315
Voltage interruptions	100%	250	C	C	C	C	C	C	C	C
Voltage dips	20%	250	A	A	A	A	A	A	A	A
	30%	25	A	A	A	A	A	A	A	A
	60%	10	A	A	A	A	A	A	A	A

Test mod	Test level	Result
Voltage variations	Unom+10%	A
	Unom-15%	A

For EN 55024

Voltage(UT): AC 230 V 50 Hz Interval(s) : 10s Times : 3										
Test mod	Test level UT %	Durations (period / ms)	Phase / Result							
			0	45	90	135	180	225	270	315
Voltage interruptions	>95%	250	C	C	C	C	C	C	C	C
Voltage dips	30%	25	A	A	A	A	A	A	A	A
	>95%	0.5	A	A	A	A	A	A	A	A

For EN 55035

Voltage(UT): AC 230 V 50 Hz Interval(s) : 10s Times : 3										
Test mod	Test level UT %	Durations (period / ms)	Phase / Result							
			0	45	90	135	180	225	270	315
Voltage interruptions	>95%	250	C	C	C	C	C	C	C	C
Voltage dips	30%	25	A	A	A	A	A	A	A	A
	>95%	0.5	A	A	A	A	A	A	A	A

13.5. Test Photographs



14. Photographs of EUT



--- END ---