

# **Mobile Network Video Recorder (8104 and 8208 Series)**

**User's Manual**







# Foreword

## Models

MNVR 8104 and 8208 Series

## Safety Instructions

The following categorized signal words with defined meaning might appear in the manual.

Symbol	Description
 DANGER	Indicates a high potential hazard which, if not avoided, will result in death or serious injury.
 WARNING	Indicates a medium or low potential hazard which, if not avoided, could result in slight or moderate injury.
 CAUTION	Indicates a potential risk which, if not avoided, could result in property damage, data loss, lower performance, or unpredictable result.
 TIPS	Provides methods to help you solve a problem or save you time.
 NOTE	Provides additional information as the emphasis and supplement to the text.

## Revision History

Version	Revision Content	Release date
V1.0.0	First release.	March 2023

## About the Manual

- The manual is for reference only. If there is inconsistency between the manual and the actual product, the actual product shall prevail.
- We are not liable for any loss caused by the operations that do not comply with the manual.
- The manual would be updated according to the latest laws and regulations of related regions. For detailed information, see the paper manual, CD-ROM, QR code or our official website. If there is inconsistency between paper manual and the electronic version, the electronic version shall prevail.
- All the designs and software are subject to change without prior written notice. The product updates might cause some differences between the actual product and the manual. Please contact the customer service for the latest program and supplementary documentation.
- There still might be deviation in technical data, functions and operations description, or errors in print. If there is any doubt or dispute, please refer to our final explanation.
- Upgrade the reader software or try other mainstream reader software if the manual (in PDF format) cannot be opened.
- All trademarks, registered trademarks and the company names in the manual are the properties of their respective owners.
- Please visit our website, contact the supplier or customer service if there is any problem occurred when using the device.

- If there is any uncertainty or controversy, please refer to our final explanation.

# Important Safeguards and Warnings

This chapter describes the contents covering proper handling of the Recorder, hazard prevention, and prevention of property damage. Read these contents carefully before using the Recorder, comply with them when using, and keep it well for future reference.

## Requirements

- Do not place or install the Recorder near a heat source or where there is direct sunshine.
- Do not install the Recorder in a humid, dusty, or smoggy place.
- Install the Recorder horizontally or in a stable place. Take measures to prevent it from falling.
- Do not drip or splash liquid onto the Recorder. Make sure that the Recorder does not bear any objects filled with liquid to prevent liquid from flowing into the Recorder.
- Prevent foreign objects from entering the Recorder, which might result in damage.
- Install the Recorder in a place with good ventilation. Do not clog the air vents of the Recorder.
- Use the Recorder only within the rated input and output range.
- Do not dismantle the Recorder without permission.
- Do not transport the Recorder with the front panel on the bottom.
- Transport, use and store the Recorder under the allowed humidity and temperature conditions.
- Do not expose the Recorder to water or excessive moisture when washing the car. A failure to follow this instruction might result in short circuit, fire, or other malfunctions.
- The dust on the circuit board will cause short circuit, which affect the normal operation of the Recorder and even damage the Recorder. To make the Recorder work stably for a long time, please regularly use the brush to remove the dust from components, including circuit board, connectors, and chassis.
- Keep the Recorder installed horizontally and make sure the internal anti-vibration components work properly.
- Unlock the HDD box before pulling it out; otherwise there might cause damage to the Recorder.
- After all the cables are connected, tie up the cables to avoid the dangers such as short circuit, heat and electric shock resulted from loose cables.
- When a Recorder is connected with a car mount display, mount the camera at least 2m away from the display. If the camera and display are too close, tune down the volume of the car mount display to avoid squeal.

## Power Requirements

- Use the battery exactly as prescribed; otherwise, the battery might catch fire or explode!
- Always replace with the same type of batteries!
- Use the wires (power cords) recommended for the region where the Recorder is used within the specified range of specifications!
- The appliance coupler is a disconnection Recorder. Keep a convenient angle when using it.
- Take care to complete the circuit connection. A failure to follow this instruction might result in Recorder damage.
- Prevent short circuit from occurring on all external wiring parts.
- After all the lines connections are completed, you can start connecting power cable.

- Ensure the project is well grounded to avoid interference to video and audio signals and avoid electrostatic or induced voltage to damage the Recorder.
- Unplug the power cable before you remove the audio/video signal cable, RS-232 or RS-485 cable; otherwise these ports might be damaged.

# Table of Contents

Foreword.....	I
Important Safeguards and Warnings.....	III
<b>1 Product Introduction .....</b>	<b>8</b>
1.1 Overview .....	8
1.2 Functions.....	8
1.3 Unpack and Check.....	9
<b>2 Structure and Installation .....</b>	<b>11</b>
2.1 Structure.....	11
2.1.1 Front Panel .....	11
2.1.2 Rear Panel .....	12
2.1.3 Port Description .....	13
2.1.4 Dimensions .....	17
2.2 Installation.....	17
2.2.1 Installing HDD .....	18
2.2.2 Installing SIM and SD Card .....	20
2.2.3 Installing Antenna .....	20
2.2.4 Fixing the Recorder .....	22
2.2.5 Connecting Cable .....	24
<b>3 Basic Settings.....</b>	<b>30</b>
3.1 Booting up Recorder.....	30
3.2 Initializing Recorder .....	30
3.3 Logging in to Recorder .....	32
3.4 Configuring IP Address .....	34
3.5 Configuring General Settings.....	36
3.5.1 Setting General Information.....	36
3.5.2 Date and Time Settings.....	36
3.6 Configuring Remote Recorders .....	38
3.6.1 Initializing the Remote Recorder .....	38
3.6.2 Adding a Remote Recorder .....	41
3.6.3 Modifying IP Address of Remote Recorder .....	43
3.7 Configuring Record .....	44
3.8 Storage Plan .....	46
3.8.1 Configuring Recording Schedule.....	46
3.8.2 Configuring Snapshot Schedule .....	47
<b>4 Function Modules Operations .....</b>	<b>49</b>
4.1 Live .....	49
4.1.1 Live Channels .....	50
4.1.2 Voice Talk.....	51
4.1.3 PTZ Control.....	52
4.2 Record Playback .....	56
4.2.1 Playback Control Bar.....	57
4.2.2 Playing Back Video Recordings.....	57
4.2.3 Clipping Recording File .....	59
4.3 Viewing Alarm Info .....	60

<b>5 System Settings .....</b>	<b>61</b>
5.1 Configuring Alarm Event Settings .....	61
5.1.1 Configuring Video Detect Settings .....	61
5.1.2 Configuring Alarm Input Settings .....	64
5.1.3 Configuring Exception .....	66
5.1.4 Configuring Alarm Out Settings.....	68
5.2 Configuring AI Settings.....	69
5.2.1 Face Detection and Recognition.....	70
5.2.2 Active and Safe Drive.....	81
5.2.3 Number Plate.....	88
5.2.4 Passenger Flow Measurement.....	90
5.3 Backing up File .....	91
5.4 Configuring Display Output Settings .....	93
5.4.1 Tour Settings.....	93
5.4.2 TV Adjustment .....	95
5.4.3 Video Mirror Settings.....	95
5.5 Configuring Camera Parameters .....	96
5.5.1 Camera Properties .....	96
5.5.2 Encode Parameters .....	97
5.5.3 PTZ.....	102
5.5.4 Channel Type.....	103
5.5.5 PoE.....	104
5.6 Configuring Network Parameters .....	105
5.6.1 Port.....	105
5.6.2 Wireless Network.....	106
5.6.3 Cellular .....	109
5.6.4 Email .....	110
5.6.5 Register.....	112
5.6.6 P2P.....	113
5.6.7 Operation Platform .....	114
5.7 Managing Storage Device .....	114
5.7.1 Basic .....	114
5.7.2 Disk Manager.....	115
5.7.3 FTP .....	116
5.8 Configuring System.....	118
5.8.1 Configuring Serial Port Parameters.....	118
5.8.2 Managing Security .....	119
5.8.3 Configuring Vehicle Info.....	120
5.9 Managing User Account .....	123
5.9.1 Managing User.....	124
5.9.2 Managing ONVIF User.....	126
5.9.3 Managing Group.....	128
5.9.4 Resetting Password.....	129
<b>6 Update.....</b>	<b>133</b>
6.1 System Version .....	133
6.2 Update.....	133
<b>7 System Maintenance .....</b>	<b>135</b>

7.1 Requirement for Maintenance .....	135
7.2 System Information .....	135
7.2.1 Log.....	135
7.2.2 Network Info.....	136
7.2.3 Disk.....	136
7.2.4 Channel Info.....	137
7.2.5 Satellite Info .....	137
7.3 Automatic Maintenance .....	138
7.3.1 Auto Reboot.....	138
7.3.2 Auto Boot up .....	139
7.3.3 Auto Shutdown System.....	139
7.3.4 Acc Delay.....	140
7.4 Backup and Restore.....	140
7.4.1 Backing up Configurations.....	140
7.4.2 Importing Configurations.....	141
7.4.3 Restoring to Default.....	142
7.5 Network Sniffer .....	143
<b>8 Operating by DSS .....</b>	<b>145</b>
<b>9 FAQ .....</b>	<b>146</b>
<b>Appendix 1 Mouse Operations .....</b>	<b>150</b>
<b>Appendix 2 HDD Capacity Calculation.....</b>	<b>152</b>
<b>Appendix 3 Cybersecurity Recommendations .....</b>	<b>153</b>



# 1 Product Introduction

## 1.1 Overview

MNVR 8104 and 8208 series mobile video monitoring products are developed on the new generation of platform, integrating video, locating, driving recording and intelligent analysis. This product can be widely used for car mount monitoring in public transportation, long-range passenger transport, police patrol, urban management patrol, cash carriers, hazardous goods transport, and logistics transport, or video monitoring in harsh environments.

It has the following features:

- 4/8 channels of IPC input and 2 channels of HDCVI analog video input.
- H.264/H.265 encoding ensures high encoding efficiency and saves storage space.
- Netcom wireless network modules (3G, 4G and Wi-Fi modules are optional) are built in after full consideration of network application needs of vehicle mount products.
- Professional car-mount design in standard size features low power consumption and novel shape.
- Wide power voltage range adapts to various car mount power supply.
- Unique HDD and SD card storage design makes recording backup and management easier.

## 1.2 Functions

Function	Description
Removable HDD	The extractable and seismic design make you lock and move the HDD easily to realize data backup. Just connect the removable HDD to the USB port of PC, you can perform data-related operations conveniently.
Storage	Stores the data in the dedicated format which cannot be falsified and ensures the data security.
Compression	Supports multi-channel audio and video signals, and each channel signal supports real-time compression by independent hardware to realize the sync between sound and image.
Backup	<ul style="list-style-type: none"><li>● Plug in a USB storage device (such as USB flash drive and mobile HDD) to back up.</li><li>● You can back up the data by downloading the files from the Recorder HDD and SD card through Internet.</li></ul>
Video playback	<ul style="list-style-type: none"><li>● Every channel supports real-time and independent recording, and you can play backward, monitor on Internet, query and download recordings.</li><li>● Supports several playback modes: Slow playback, fast playback, backward playback, and frame-by-frame playback.</li><li>● Displays time when the event occurred during playback.</li></ul>
Operation through network	Supports remote operations through network, such as real-time remote monitoring, recorded video search and playback, and PTZ control.

Alarm linkage	<ul style="list-style-type: none"> <li>● Outputs signals such as car door signal, cornering lamp signal, reversing and braking signal, to give an indication and take a record.</li> <li>● Supports two channels of electric level alarm output to realize easy alarm linkage.</li> <li>● Supports protective circuit for alarm input port and alarm output port, which protect the Recorder from damage.</li> </ul>
Communication interfaces	<ul style="list-style-type: none"> <li>● Offers RS-485 interfaces to connect to external Recorders.</li> <li>● Offers RS-232 interfaces to connect to external car mount display.</li> <li>● Offers standard Ethernet ports that support remote network accessing.</li> </ul>
Smart operations	<ul style="list-style-type: none"> <li>● Mouse operations.</li> <li>● The same settings in the menu can be quickly copied and pasted.</li> </ul>
Satellite positioning	Supports positioning function and recording linkage. Recording search can be linked with vehicle moving track.
Cellular, Wi-Fi networks	Adopts the latest wireless communication technology, which has improved the manageability of the Recorder.
Dual stream	To cope with the low-bandwidth and instability of wireless network, the Recorder adopts the dual stream technology (respectively encode the real-time video and encode video in network transmission) to optimize the coding of network transmission, which improves the control capability of wireless network transmission.
Rollover and collision detection	The integrated G-sensor supports rollover and collision detection and timely releases alarms through the platform.

## 1.3 Unpack and Check

When you receive the device, unpack the box for checks.

Firstly, check if there is any damage on the device appearance. Secondly, open the accessory box to check if the accessories are complete against the packing list.



For tools or accessories not mentioned in the list, please purchase them.

Table 1-1 Packing list

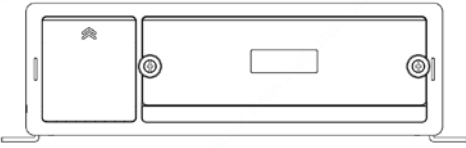



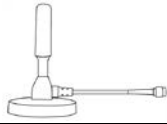
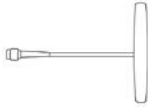



Figure	Name	Quantity
	Device	1
	Lug	2
	Pass key	2

Figure	Name	Quantity
	GPS antenna	1
	3G/4G antenna	1
	Wi-Fi antenna	1
	Accessories bag	1
	Network port waterproof connector	1
	Alarm signal connector	1
	Quick start guide	1

### Matching Product (not supplied)

1. DSM camera
2. ADAS camera
3. SD card
4. SIM card
5. HDD (max. 2 TB per disk)

# 2 Structure and Installation

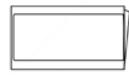
Describes the installation of hardware. Prior to installation, you need to know about the front panel, rear panel, structural sizes, and interface definition of the device. Then you can install corresponding HDD, SIM card, SD card, antenna, and devices.



The following figures are for reference only, and the actual product shall prevail.

## 2.1 Structure

### 2.1.1 Front Panel

Figure 2-1 Front panel of MNVR8104/8208

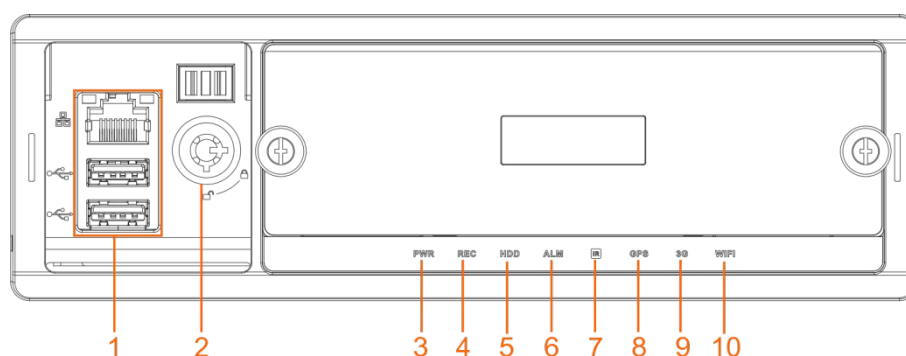





Table 2-1 Descriptions of interfaces and indicators

No.	Item	Description
1	RJ-45 network port	One network port.
	USB interface	Two USB ports that connect to peripheral devices such as USB storage device and mouse.
2	Lock switch (Device switch)	When pulling out HDD, the Device must be unlocked, and if the Device is turned on, it will shut down automatically. To protect the HDD, this Device cannot be turned on if it is unlocked. Turning on the device only after locking it
3	PWR	The red light is always on when the Device is powered on, and off when the Device is powered off
4	REC	Recording status indicator. The blue light is always on when recording, and off when not
5	HDD	HDD status indicator. The light keeping blue indicates that there is HDD and the light off indicates no disk.
6	ALM	Alarm status indicator. The light keeping red indicates alarm of video loss, low battery and high temperature and off when no alarm occurs.
7	IR	Receives infrared signal from remote control.

8	GPS	<p>GPS status indicator. Glows blue when GPS positioning is working properly, and the indicator is off when GPS function is not enabled.</p> <p> This function is supported on the Device with GPS positioning module.</p>
9	3G	<p>3G status indicator. Glows blue when 3G dial-up is working properly, and the indicator is off when 3G function is not enabled.</p> <p> This function is supported on the Device with 3G module.</p>
10	Wi-Fi	<p>Wi-Fi status indicator. Glows blue when Wi-Fi connection is correct, and the indicator is off when Wi-Fi is disconnected.</p> <p> This function is supported on the Device with Wi-Fi module.</p>

## 2.1.2 Rear Panel

The illustration of the rear panels of the Recorder. Table 2-2 describes interface functions. For interface definitions, see "2.1.3 Port Description."

Figure 2-2 Rear panel

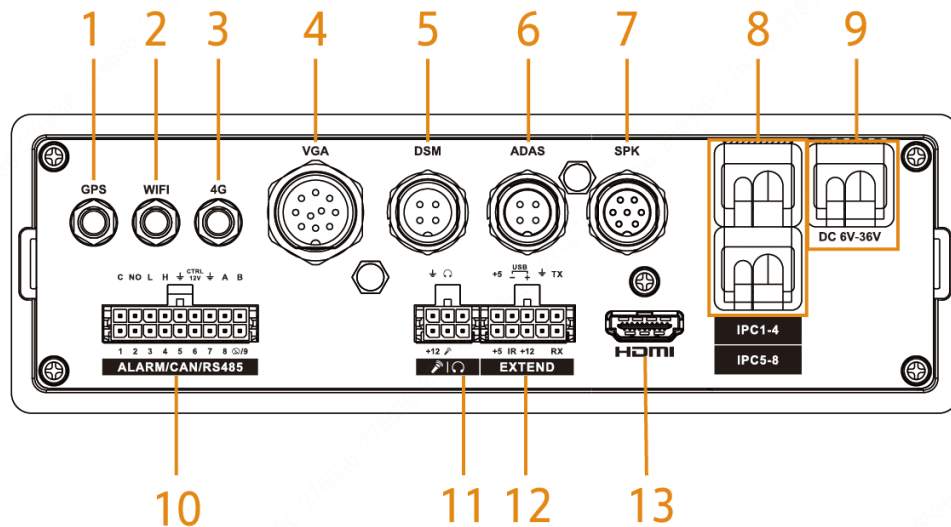





Table 2-2 Descriptions of rear panel interfaces

No.	Port	Description
1	Positioning antenna port	<p>Connects with positioning antenna for receiving satellite positioning signals.</p> <p> This function is supported on the Recorder with positioning module.</p>
2	Wi-Fi antenna port	<p>Connects to Wi-Fi antenna and receives Wi-Fi signals.</p> <p> This function is supported on the Recorder with Wi-Fi module.</p>

3	3G/4G antenna port	Connects to 3G/4G antenna for receiving 3G/4G signals.  This function is supported on the Recorder with 3G/4G modules.
4	VGA	Outputs analog video data to the connected display with VGA port.
5	DSM	Connects to camera that detects tired face.
6	ADAS	Connects to camera that helps drive.
7	SPK port	Connects to mobile small-size display to show information and give out voice reminding. See "2.1.3.7 SPK."
8	IPC1-4	Connects to IP camera. 
	IPC5-8	Different devices corresponds to different number of channels
9	Power cable	Connects to DC 6V-DC 36V power supply for getting power from the car accumulator. <ul style="list-style-type: none"> <li>• The red end with fuse is the anode of the power supply (always-live wire).</li> <li>• The black wire is the ground wire.</li> <li>• The orange one is the ACC signal (key starting wire).</li> </ul>
10	ALARM/CAN/485	<ul style="list-style-type: none"> <li>• Alarm input/output port: Includes alarm input/output port, grounding, and 12V output port.</li> <li>• CAN port: Used for data transfer between the Device and vehicle CAN network or other devices with CAN port</li> <li>• A, B: Controls PTZ operations.</li> </ul>
11	Voice talk port	Connects to voice talk device.
12	EXTEND port	See "2.1.3.3 Extend."
13	HDMI interface	Used to connect with HDMI display.

## 2.1.3 Port Description



This Manual only describes functions of all jacks of each interface. You can follow these descriptions to prepare cables or contact our sales staff for purchasing cables.

### 2.1.3.1 Power Input

Figure 2-3 Power input interface

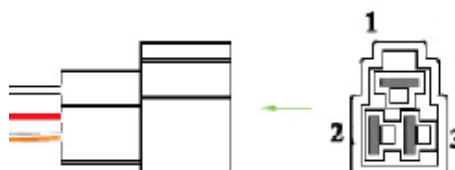
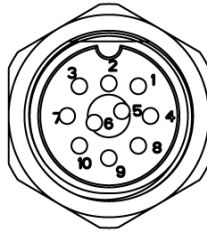

Table 2-3 Power input interfaces (left to right)

No.	Description
1	Ground cable (in black)
2	Anode input (in red)
3	ACC signal input (in orange)

### 2.1.3.2 VGA

Figure 2-4 VGA port



No.	Function	No.	Function	No.	Function
1	+12V/1A output	5	Audio output	9	VGA line sync
2	Ground line	6	VGA_B	10	VGA field sync
3	VGA_G	7	VGA_R	—	—
4	RXD_232	8	TXD_232	—	—

### 2.1.3.3 Extend

Figure 2-5 EXTEND port

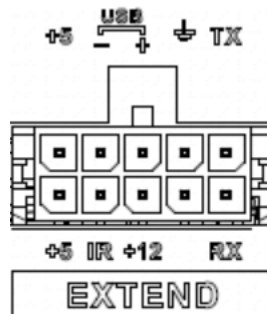

Name	Function
+5	USB +5V (up)
+5	USB +5V (low)
-	USB data- and USB data+ that connect to USB port.
+	
IR	Reserved for custom.
+12	+12V/1A output.
⏏	Ground
VO	AV video output
RX	RS-232 serial port sender and receiver that connects to RS-232 port
TX	

### 2.1.3.4 Voice Talk

Figure 2-6 Voice talk port

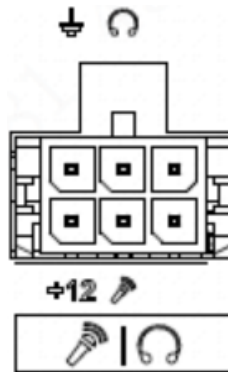

Name	Function
+12	+12V output
⏏	Ground
🎤	Mic In that can connect to microphone.
🎧	Mic Out that can connect to earphone.

### 2.1.3.5 DSM

Figure 2-7 DSM port



Table 2-4 DSM port description

No.	Description
1	VCC
2	Power source ground port
3	Audio signal port
4	Video signal port



### 2.1.3.6 ADAS

Figure 2-8 ADAS port



Table 2-5 ADAS port description

No.	Description
1	VCC
2	Power source ground port
3	Audio signal port
4	Video signal port

### 2.1.3.7 SPK

Figure 2-9 SPK port

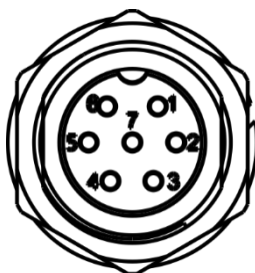

Table 2-6 SPK port description

No.	Description
1	12V_EXT
2	GND
3	RXD_232
4	TXD_232
5	AUDIO_OUT
6	AUDIO_GND
7	NC

## 2.1.4 Dimensions

Figure 2-10 Dimension (1) [Unit: mm (inch)]

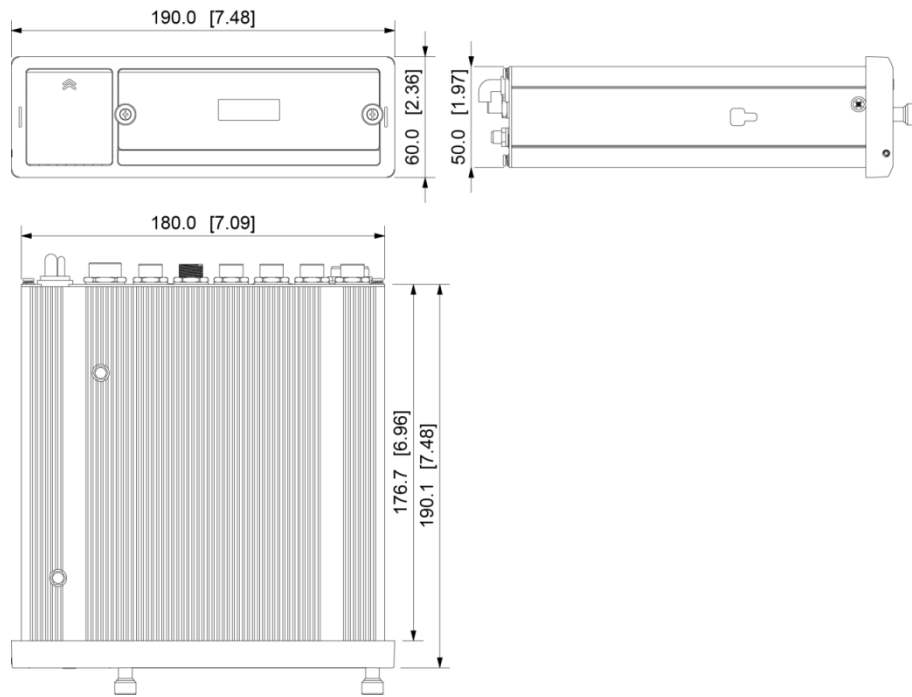
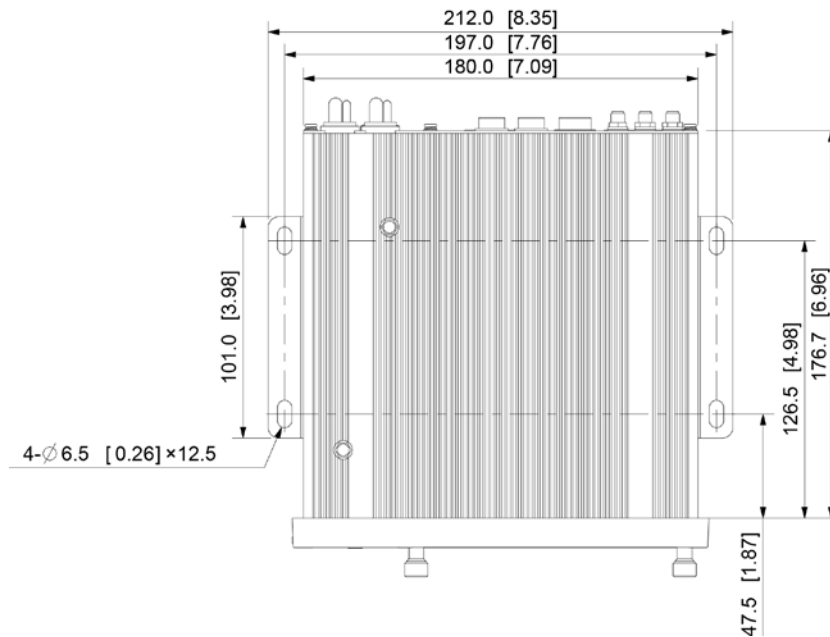

Figure 2-11 Dimension (2) [Unit: mm (inch)]



## 2.2 Installation

When you receive the Recorder, unpack the box to check the Recorder appearance and structures, and then install the SIM card and SD card.



- Before completing the installation, make sure the Recorder is disconnected from power, and do not plug or unplug components when the power is connected.

- After the installation is complete, the Device electronic lock must be in "locked" status before powering on the Device.

## 2.2.1 Installing HDD

MNVR8104 series support 1 HDD, and MNVR8208 series support dual HDDs. This chapter takes MNVR8208 series for example.

**Step 1** Gently press the left front cover.

The left front cover automatically opens.

**Step 2** Use a pass key to unlock the door.

Figure 2-12 Open door lock switch (dual HDDs).

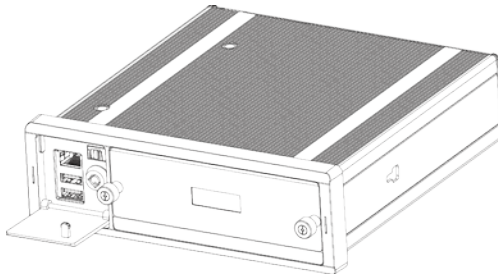

**Step 3** Loosen the two screws at the front panel and take out the HDD carrier along the guide rail.

Figure 2-13 Take out the HDD carrier (dual HDDs).

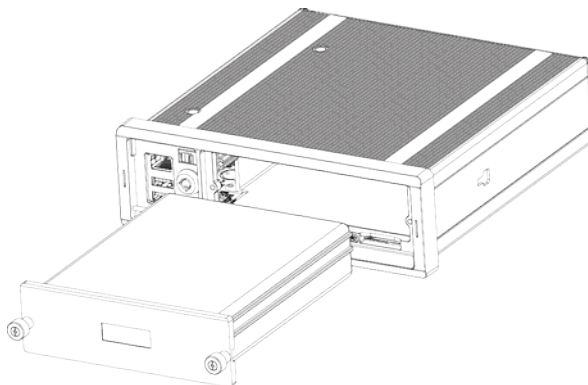

**Step 4** Loosen two screws on the back panel of the HDD carrier, take out the rear carrier panel, and remove the HDD carrier enclosure.

Figure 2-14 Remove the HDD carrier (dual HDDs)

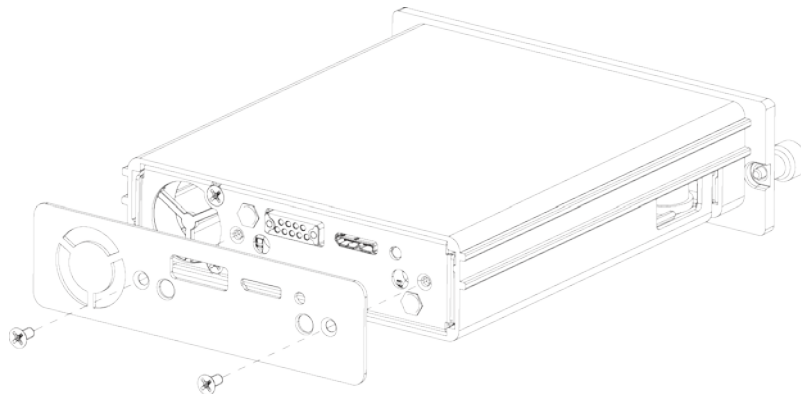

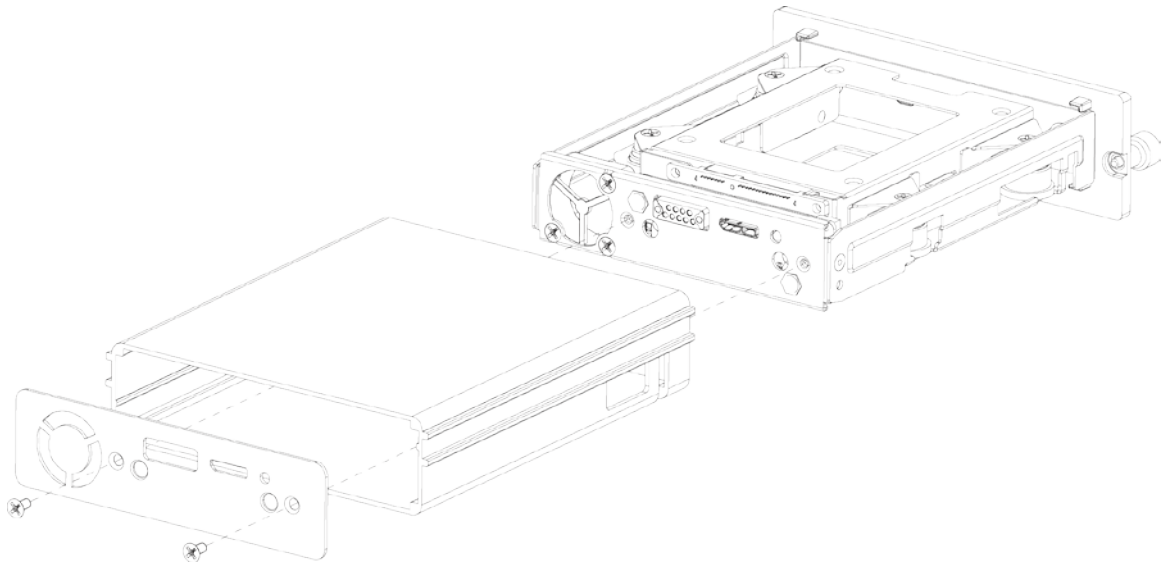

**Step 5** Loosen two screws of the HDD holder and remove the holder.

Figure 2-15 Remove the HDD holder (dual HDDs)

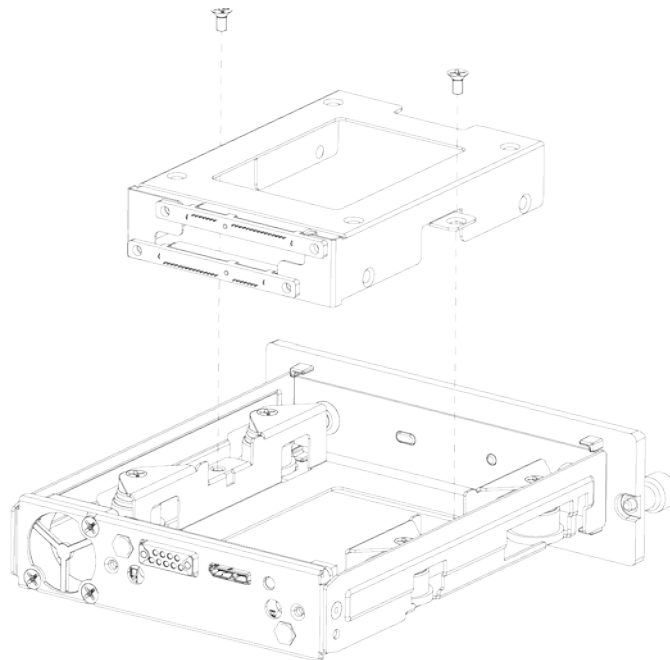

**Step 6** Use four screws to fix each HDD and the HDD holder, and install the HDD holder back to the Recorder.

Fix the upper HDD to the top of the HDD holder, and the lower HDD to the side of the HDD holder.

Figure 2-16 Installing HDD (dual HDDs)

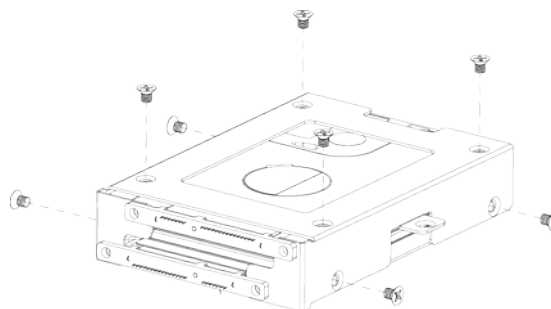

**Step 7** Install the HDD carrier enclosure in place along the rails, and then fix the HDD enclosure rear panel with two screws.

Place the HDD carrier back to the Recorder, tighten two screws and close the door lock.

## 2.2.2 Installing SIM and SD Card

By default, the Device is delivered without the SIM card and SD card. Install them as you need.

- To set up a dial up network connection, you need to purchase and install your own SIM card.
- To store recording data, you need to purchase and install an SD card.



Only standard SIM card is supported.

**Step 1** Push the SIM card pinhole using a pin, and then pull out the card slot.

**Step 2** Put the SIM card into the slot.

**Step 3** Push back the card slot.

### Preparation

The Recorder is powered off.

### Procedure

The SIM card slot and SD card slot are inside the Device.

**Step 1** Gently press the left front cover.

The left front cover automatically opens.

**Step 2** Use the pass key to unlock the Recorder.

**Step 3** Loosen the two screws at the front panel and take out the HDD carrier along the guide rail. Open the card slot cover. You can see SIM card slot and SD card slot in Figure 2-17.

**Step 4** Insert SIM card and SD card into the slot, and then push back the slot.

Figure 2-17 Install SD card

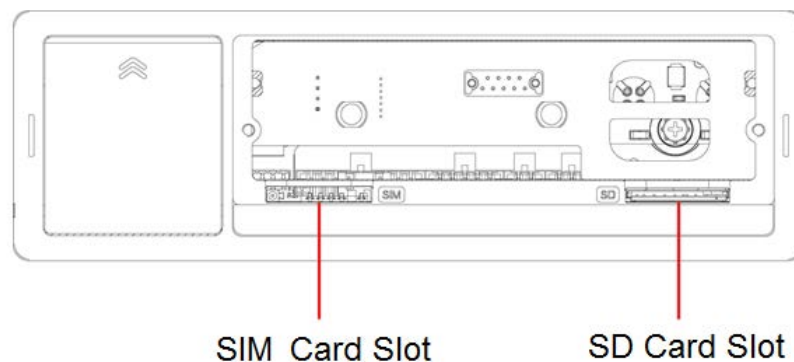

**Step 5** Close the slot cover, and then use the pass key to lock the Recorder.

## 2.2.3 Installing Antenna

The Recorder antenna is installed to connect the Recorder to the network and to locate the position of the vehicle.

### 2.2.3.1 Installing Network Antenna



When installing sticking antenna, make sure there is no metal material below the sticking spot. For installation of mobile network antenna, see Figure 2-18. The flat antenna is recommended to be vertically attached to near the wind shield (such as on the instrument panel, or under the wind shield), or concealed inside the instrument panel.

Figure 2-18 Inside installation of mobile network antenna



### 2.2.3.2 Installing Antenna

Positioning method include the currently mainstream GPS positioning, with corresponding GPS antenna.

In this manual, GPS antenna is used as an example to illustrate the installation steps of locating antennas. The installation process of other locating antenna is identical.

#### 2.2.3.2.1 Outside Installation

**Step 1** Place the GPS antenna on the left front of the roof. See Figure 2-19.

The antenna is magnetically attached to the roof of the vehicle. For more reliable fixation, the GPS antenna can be pasted on the roof with 3M adhesive in the accessories.



To make the sensitivity and accuracy of positioning free of interference, ensure that there is no high-power electrical or electronic interference source (such as a fan or AC compressor) or obstacles within 1 meter around the GPS antenna.

**Step 2** Insert the GPS antenna lead wire into the antenna lead hole on the roof of the vehicle and connect to the GPS antenna port inside the vehicle.

The requirements of the GPS antenna lead hole are as follows.

- The inner radius is at least 10mm.
- It must be waterproof.
- Easy to replace and maintain the antenna.

Figure 2-19 Outside Installation



### 2.2.3.2.2 Inside Installation

When limited by waterproof and wiring requirements, the antenna can be installed inside the vehicle.

You can place the antenna horizontally on the dashboard close to the windshield, and make the GPS cable facing upward to enhance the signal, as shown in Figure 2-20.

Figure 2-20 Inside Installation



### 2.2.4 Fixing the Recorder



- Install the Recorder on the vehicle where it cannot be seen from outside. Avoid places with

high temperature or near the air conditioning system. High temperature shortens the life of the Recorder. If going into the Recorder, the condensing water from the air conditioner can short circuit or burn the Recorder.

- Connect the Recorder with devices such as mobile display first. Then power on the Recorder.

**Step 1** Install lugs onto the Recorder.

- 1) Place washers onto the fixing screw.
- 2) Use fixing screws with washers, mount lugs to the bottom of the Recorder respectively, and tighten the lugs.

Figure 2-21 Install the lugs onto the Recorder.

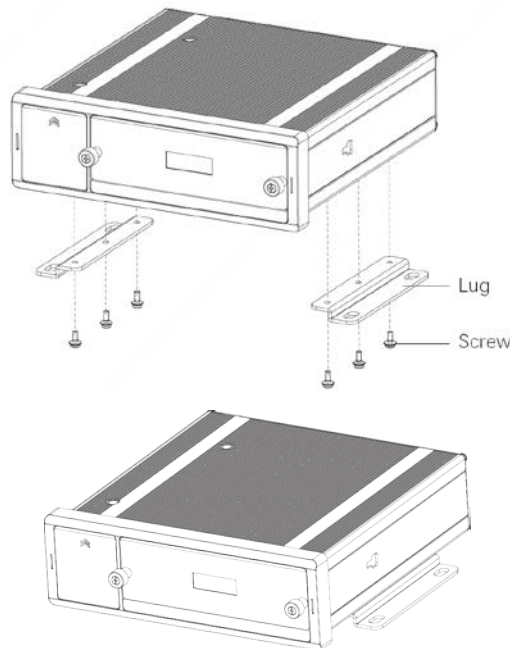

**Step 2** Fix the Recorder onto the vehicle.

- 1) Punch holes on the vehicle according to the installation dimensional drawing.
- 2) Use screws to fix the Device onto the vehicle.

Figure 2-22 Fix the Recorder onto the vehicle

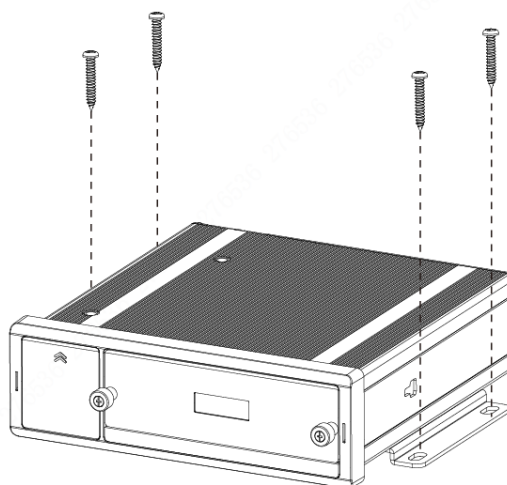

**Step 3** Connect cables to the Recorder.

- Check the voltage of the accumulator. The working voltage of this Recorder ranges from 6V to 36V. To make sure the Recorder works stably, directly get power supply from the accumulator.



- When installing the basic wires, do not use excessive force to pull the control wires.

## 2.2.5 Connecting Cable

Introduce the connection of power cable and alarm input and output.

### 2.2.5.1 Connecting to Power Cables



- Before connecting the power cable, make sure the input voltage is between 6V DC and 36V DC. If it is out of the range, it will damage the Recorder.
- Make sure that the positive and negative poles of the power are connected correctly. If not, the Recorder may be damaged.
- The diameter of the power cable should be more than 1.0 mm<sup>2</sup>. Use power cables recommended by our company.
- When connecting the cables to the Recorder, make sure that the main power switch of the vehicle is turned off and the key of the vehicle is placed in the off state.

#### 2.2.5.1.1 Overview

For power cable of the Recorder, see Figure 2-23.

Connect one end of the power cable to the power port of the Recorder or directly use the power cable from the Recorder. Connect the other end to the vehicle battery.

- The red one with fuse is positive pole of the power (normal wire).
- The black one is the grounding cable.
- The orange one is the ACC signal (key starting wire).

Figure 2-23 Power cable

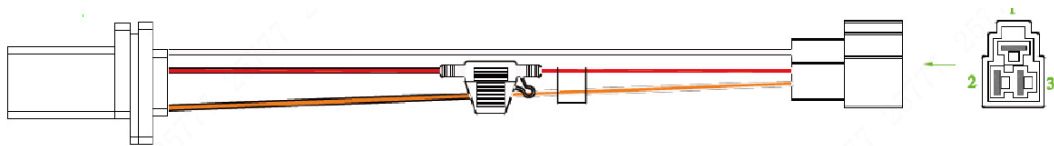

#### 2.2.5.1.2 Obtaining Connection Modes

To ensure correct cable connection, it is necessary to obtain the connection mode of the main power switch through three methods (By connection mode here, it means the main power switch is connected to the positive or negative pole of the battery).

- Consult the vehicle manufacturer the connection modes of the main power switch of the vehicle.
- Measure with a multimeter: Disconnect the main switch, and then measure the voltage between the vehicle body and the positive pole of the vehicle battery. If the voltage is 12V or 24V, it means that the main switch disconnects the positive pole. If the voltage is 0V, then the main switch disconnects the negative pole.
- Visual inspection: Whether the switch cable near the vehicle battery is connected to the positive pole or the negative pole.

### 2.2.5.1.3 Connecting Operation

The Recorder must be connected to the ground wire, ACC signal, and constant electricity.

**Step 1** Enable the main power switch on the vehicle, place the key in the OFF state, and then measure the normal live electricity of the vehicle.

Use a multimeter to measure the voltage on the fuse by switching to the DC voltage range. When the multimeter detects voltage, it measures the normal live electricity on the vehicle. Generally, the voltage is 24V DC for large vehicles and 12V DC for small vehicles. However, this is subject to actual data.

**Step 2** When the vehicle key is placed at the ACC state or the ON state, the ACC signal of the vehicle is measured.

Use a multimeter to measure the voltage on the fuse by switching to the DC voltage range. When the multimeter detects voltage, remove the car key. If the voltage changes to 0V, it means that the measured signal is ACC on the car.

**Step 3** Turn off the main power switch on the vehicle, and place the key in the OFF state.

**Step 4** Connect the power cable according to the main power switch installation mode. See Figure 2-24 and Figure 2-25.



- Before connecting with power cord, select proper fuse. 7.5A fuse is recommended.
- The positive and negative poles of the battery must be equipped with protective devices such as fuses.
- For vehicles where the main power switch is installed at the cathode of the accumulator, isolation installation is needed.

Figure 2-24 Vehicle main power switch installed on the positive pole of the vehicle battery

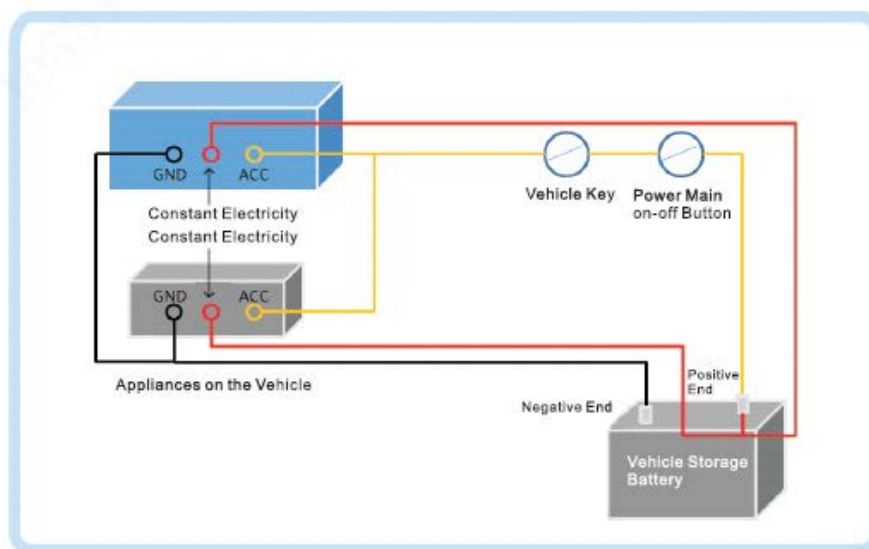
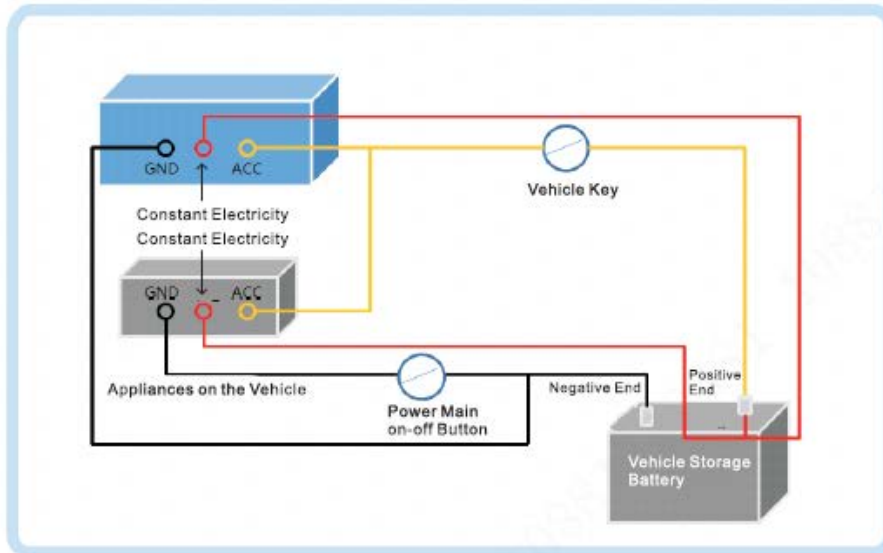

Figure 2-25 Vehicle main switch installed on the negative pole of the vehicle battery



## 2.2.5.2 Audio and Video Input and Output Connection

This section helps you understand the connection of audio and video input and output when you need to use this function.

### 2.2.5.2.1 Audio and Video Input

The video and audio data is input through RJ-45 network port. When connecting cable, the waterproof connector needs to be installed.

**Step 1** Take out the waterproof connector from the accessory box, and connect the gasket toward the arrow direction onto the waterproof connector. See Figure 2-26.

Figure 2-26 Gasket installation



**Step 2** Put the network cable (without Ethernet port) through the main part of waterproof connector, gasket and encap, and then make the Ethernet plug. See Figure 2-27.

Figure 2-27 Cabling and Ethernet plug making



**Step 3** Connect the rubber gasket to the Ethernet port. See Figure 2-28.

Figure 2-28 Rubber gasket installation



**Step 4** Inset the Ethernet plug into the Ethernet port, and then tighten the waterproof connector. See Figure 2-29.

Figure 2-29 Waterproof connector fastening

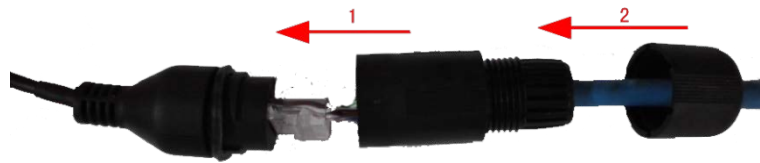

See Figure 2-30 for the connected waterproof connector.

Figure 2-30 Connection completed



## 2.2.5.2.2 Audio and Video Output

### Video Output

The Recorder is provided with one CVBS (PAL/NTSC 1.0V<sub>P-P</sub>, 75Ω) port and VGA port, and supports the simultaneous output from these two ports.

Read the following contents carefully before using the computer instead of monitor.

- For VGA output, you need to prepare a VGA adapter cable to connect to computer.
- To extend the Device life, do not keep the Device running for a long time.
- Regular demagnetizing helps keep the monitor working properly.
- Stay away from devices with strong electromagnetic interference.

### Audio Output

The audio output signal parameter is larger than 200mv 1KΩ. The audio output port can directly connect to the display with audio function on the vehicle or active speaker, and the port can also drive other sound output devices through amplifier.

### 2.2.5.3 Alarm Input and Output Connection

Before using the alarm function, learn about the connections method of alarm input and output port.

#### Alarm Input

- The alarm input port supports alarm signal from ground and Recorder of 12V-24V voltage.
- If the alarm Recorder is connected to the Recorder and other Recorders, use relay for isolation.

#### Alarm Output

The alarm output port cannot be connected to high-power load (less than 1A). When constructing the output circuit, the excessive current should be prevented from causing damage to the relay. Use the contactor for isolation when applying high-power loads.

#### No Restriction for Alarm Input Types

The alarm input can be Normally Open (NO) or Normally Closed (NC).

#### 2.2.5.3.1 Port Definition

Figure 2-31 Alarm input/output port

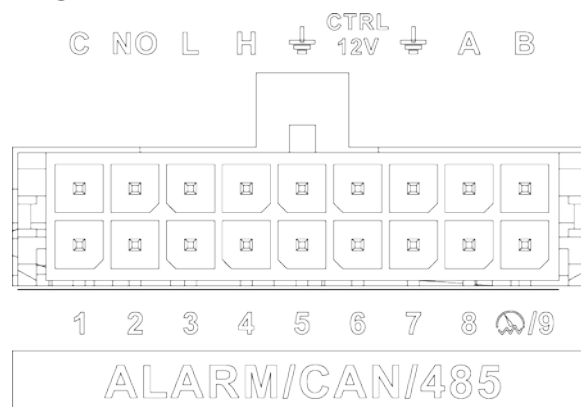

Name	Function
1-9	Alarm input 1-9, where 1-8 are local alarm input, 9 is a combination of impulse and alarm (but only one function, impulse or alarm, can be used).
C, NO	Outputs alarm signal to alarm device. <ul style="list-style-type: none"> <li>• "NO" represents normally open type.</li> <li>• C: Common alarm output port.</li> </ul>
L, H	CAN port.
⏏	Ground line.
CTRL 12V	12V/0.75A output with switch control.
A, B	RS-485 port that connects to speed dome with PTZ function.

#### 2.2.5.3.2 Alarm Input Port

- Both NO and NC are supported.

- The GND of alarm detector is in parallel connection with COM (the power supply of alarm detector should be from external power source). See Figure 2-32.
- The GND of alarm detector is in parallel connection with GND of Recorder.
- Connect the NC port of alarm detector to the alarm input port (ALARM).
- When supplying power from external power source to the alarm Recorder, the alarm Recorder should be common-grounded with the Recorder.

Figure 2-32 Normally Closed alarm input illustration

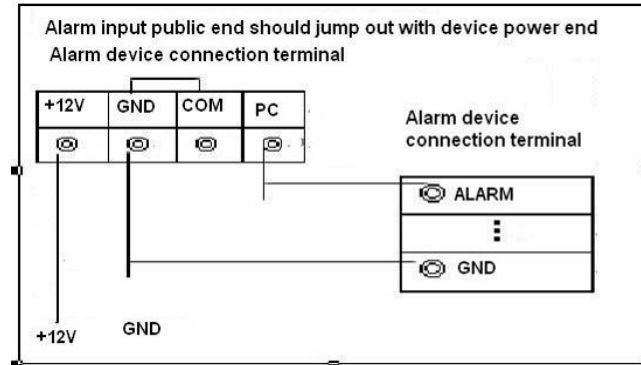

# 3 Basic Settings

This Recorder can be operated following instructions on the local interface or web interface. This section introduces the web interface instructions. The Local interface is similar and would not be elaborated here.



Browsers including Safari, Firefox, and IE are supported.

## 3.1 Booting up Recorder



- Before booting up the Recorder, check if input voltage matches rated voltage of the Recorder.
- Refer to international standard to offer the power input (power input that is with stable power value and less interference) to ensure the Recorder works stably and prolong its service life.
- In the first power-on, the Recorder needs connection to the ACC to work as intended.

Rotate the Recorder key to  and rotate the vehicle key to ACC position. The power indicator is on, and the Recorder is ready for work.



For the first boot up or after restoring to the default factory settings, the initialization interface is displayed on the screen. Follow on-screen instructions to initialize your Recorder prior to use.

## 3.2 Initializing Recorder

When you are opening the Recorder for the first time or you have allowed your system to be restored the factory settings, you need to initialize the Recorder. Only after that can you operate and configure your Recorder.

### Preparation

Please make sure the correct network connection between PC and the Recorder.

### Procedure

Step 1 Open the browser, enter the Recorder IP address (the default IP address is 192.168.1.108), and then press Enter.

The **Device Initialization** interface is displayed.

Figure 3-1 Device initialization interface

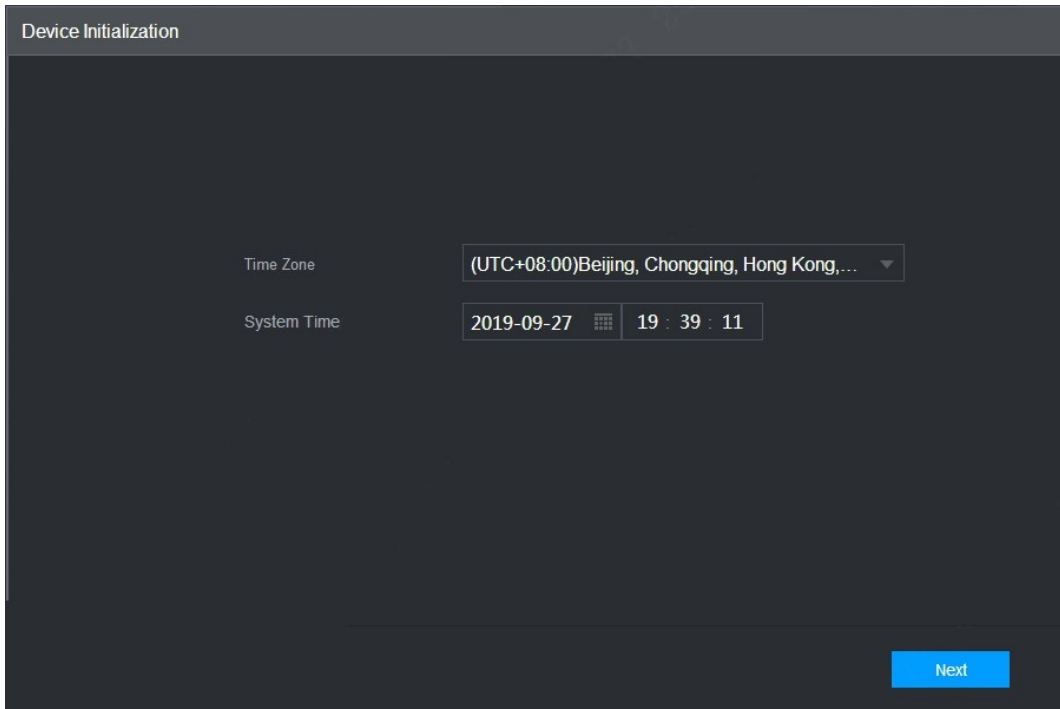

**Step 2** Select **Time Zone** and **System Time**. Then click **Next**.

Figure 3-2 Password protection

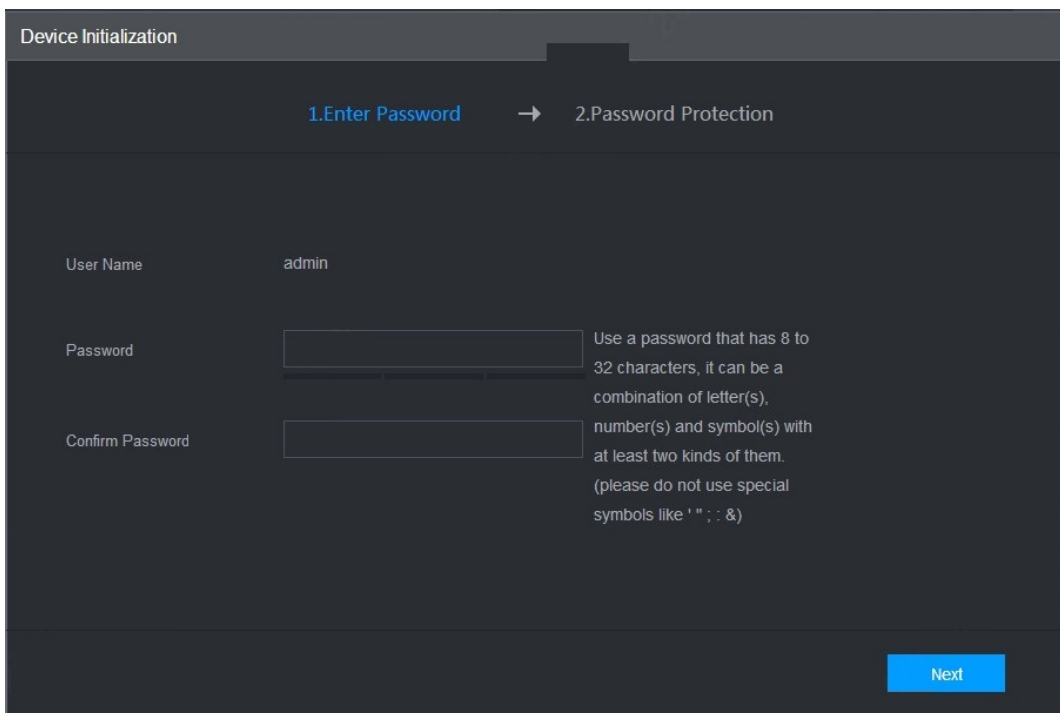

**Step 3** Enter your password and enter it again to confirm it. Then click **Next**.

Then an interface is displayed to let you fill in the password protection settings. See Figure 3-3.



You are recommended to use strong password. The password must consist of 8 to 32 non-blank characters and contain at least two types of characters among upper case, lower case, number, and special character (excluding ' " ; : & ).



Figure 3-3 Password protection settings

The screenshot shows a 'Device Initialization' screen with a progress indicator at the top showing '1. Enter Password' and '2. Password Protection'. The '2. Password Protection' step is active. Below the progress indicator, there are three sections for password protection settings:

- Email Address:** A checkbox is checked, and there is an empty text input field. To the right, it says 'To reset password, please input properly or up...'
- Security Questions:** A checkbox is checked. There are three questions, each with a dropdown menu and an answer input field:
  - Question 1: 'What is your favorite children's book?' (dropdown)
  - Answer: (input field)
  - Question 2: 'What was the first name of your first boss?' (dropdown)
  - Answer: (input field)
  - Question 3: 'What is the name of your favorite fruit?' (dropdown)
  - Answer: (input field)

At the bottom right, there are two buttons: 'Back' and 'Finished'.

Step 4 You are recommended to fill in the email address and answer the password protection questions.

Step 5 Click Finished.

### 3.3 Logging in to Recorder

You can log in to and then configure the Recorder.

Step 1 Open the browser, enter the Recorder IP address, and then press Enter.

The **Login** interface appears. See Figure 3-4.

Figure 3-4 Web login interface

The screenshot shows the 'Mobile Video Recorder' web login interface. It features a dark background with the title 'Mobile Video Recorder' at the top. Below the title, there are two input fields: the first contains the username 'admin', and the second contains a masked password '.....' with an eye icon to toggle visibility. Below the password field, there is a link that says 'Forgot Password'. At the bottom, there is a prominent blue 'Login' button.

Step 2 Enter username and password, and click Login.

The web interface is displayed.



- For **admin** account, if you forget password, click **Forgot password** to find back the password. For details, see "5.9.4Resetting Password".

Figure 3-5 WEB interface



Table 3-1 Description of WEB interface





No.	Name	Description
1	SETTING	Click  or <b>Setting</b> . See Figure 3-5.
2	Time	Display the current time.
3	User	Display the user that currently logs in.
4	Logout	Click  , the system displays as Figure 3-7. Select <b>Logout</b> or <b>Restart</b> as needed.
5	QR Code	Click  , the system displays as Figure 3-8. Scan device serial number to add the device to APP.
6	Desktop	Click  to return to WEB main interface.
7	Operation	System operation

Figure 3-6 Setting

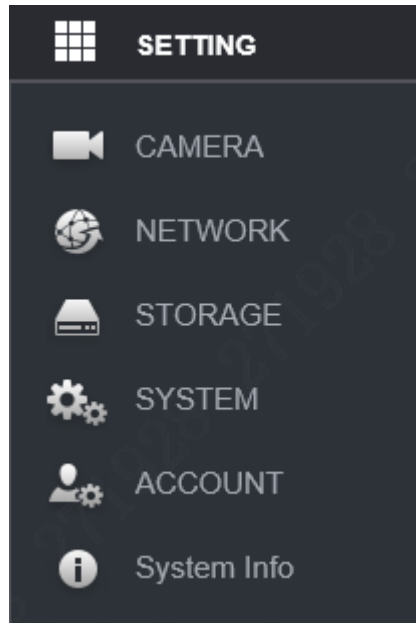

Figure 3-7 Logout

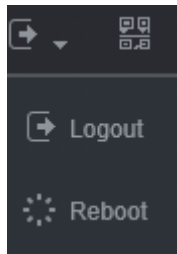

Figure 3-8 QR Code



### 3.4 Configuring IP Address

Connect the Recorder to the network and make sure the Recorder can communicate with other Recorders in the network diagram.

## Preparation

Make sure the Recorder is connected to the network properly.

## Procedure

**Step 1** Select SETTING > NETWORK > TCP/IP.

The **TCP/IP** interface is displayed. See Figure 3-9.

Figure 3-9 TCP/IP

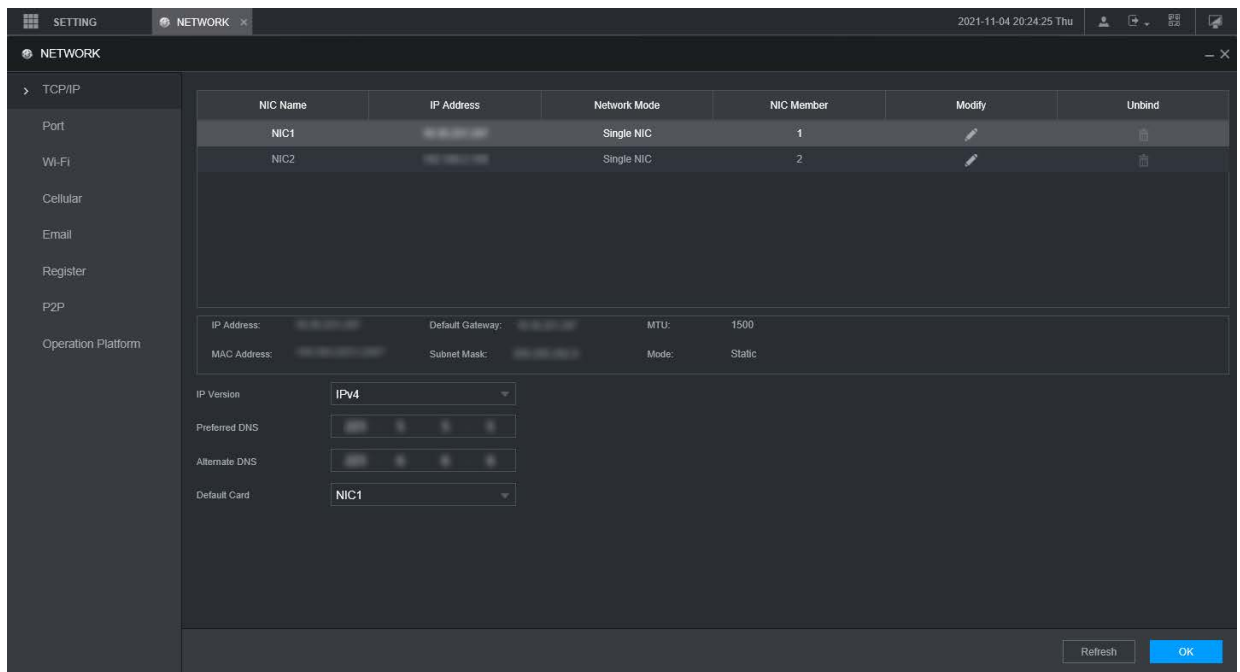

**Step 2** Configure serial port parameters. See Table 3-2.

Table 3-2 Network settings

Parameter	Description
IP Version	Click <b>IPv4</b> or <b>IPv6</b> . Both versions are supported.  For IPv6 version, in the <b>IP address</b> box, <b>Gateway</b> box, <b>Preferred DNS</b> box, and <b>Alternate DNS</b> box, enter 128 bits and cannot be blank.
MAC address	Host's MAC address, cannot be modified.
DHCP	Obtains IP address automatically. With DHCP enabled, <b>IP Address</b> , <b>Subnet Mask</b> and <b>Default Gateway</b> cannot be configured. You can check the current IP address whether the DHCP takes effect or not.
IP address	According to your network plan, enter the modified IP address, gateway and subnet mask.
Subnet Mask	
Default gateway	 IP address and gateway must be in the same network segment.
Preferred DNS	IP address of the preferred DNS
Alternate DNS	IP address of the alternate DNS

**Step 3** Click **OK**.

## 3.5 Configuring General Settings

You can configure the basic settings, including time and date settings.

### 3.5.1 Setting General Information

Set the general information of the Recorder, including video recording strategy when the Disk is full, recording length, menu standby duration, license plate, and more.

**Step 1** Select SETTING > SYSTEM > General > Basic.

The **Basic** interface is displayed. See Figure 3-10.

Figure 3-10 Basic

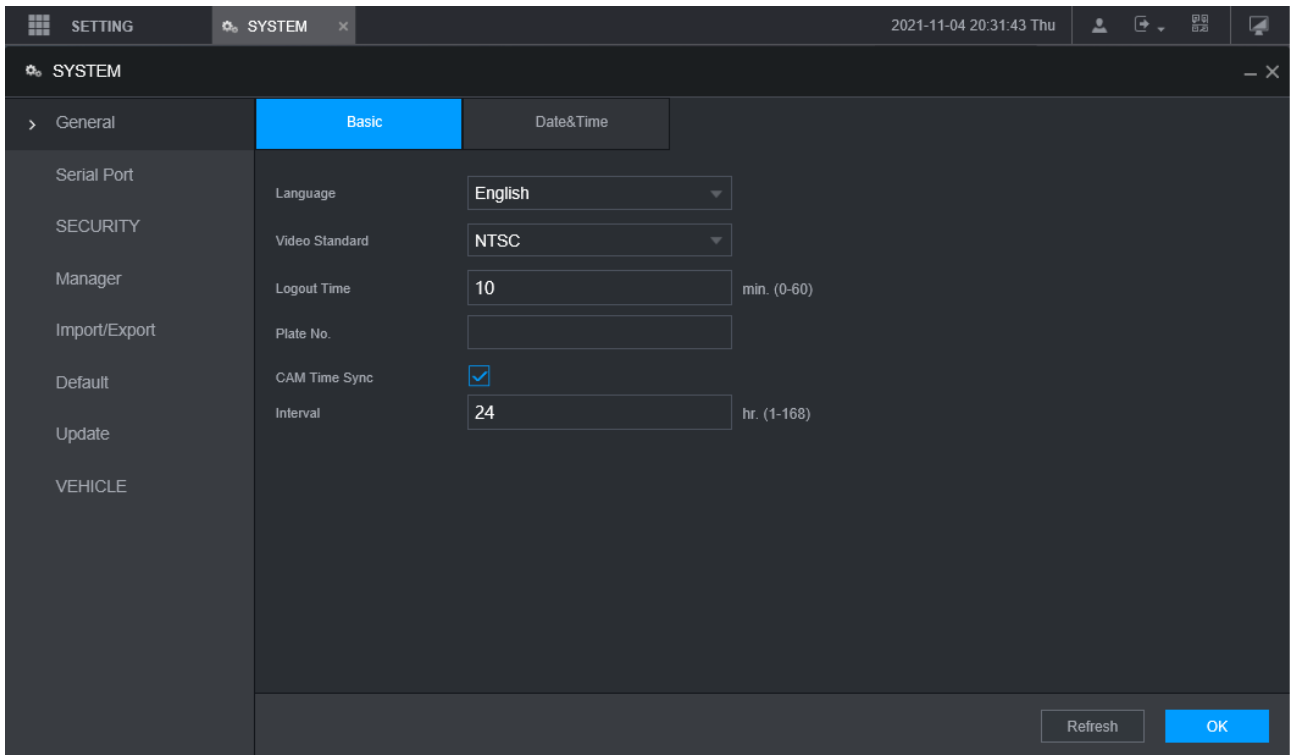

**Step 2** Configure more settings.

Table 3-3 General settings parameters description

Parameter	Description
Language	Select a language for the Recorder system.
Video Standard	Displays the video encode standard.
Logout Time	Configure time from 0 min to 60 min.
Plate No.	Enter the license plate number of vehicle where the Recorder is located.
CAM Time Sync	You can click the <b>CAM Time Sync</b> check box and enter the interval for camera sync with the Recorder.

**Step 3** Click **OK**.

### 3.5.2 Date and Time Settings

You can configure settings such as date format, time format, and timing mode.

**Step 1** Select SETTING > SYSTEM > General > Date & Time.

The **Date & Time** interface is displayed. See Figure 3-11.

Figure 3-11 Date and time settings

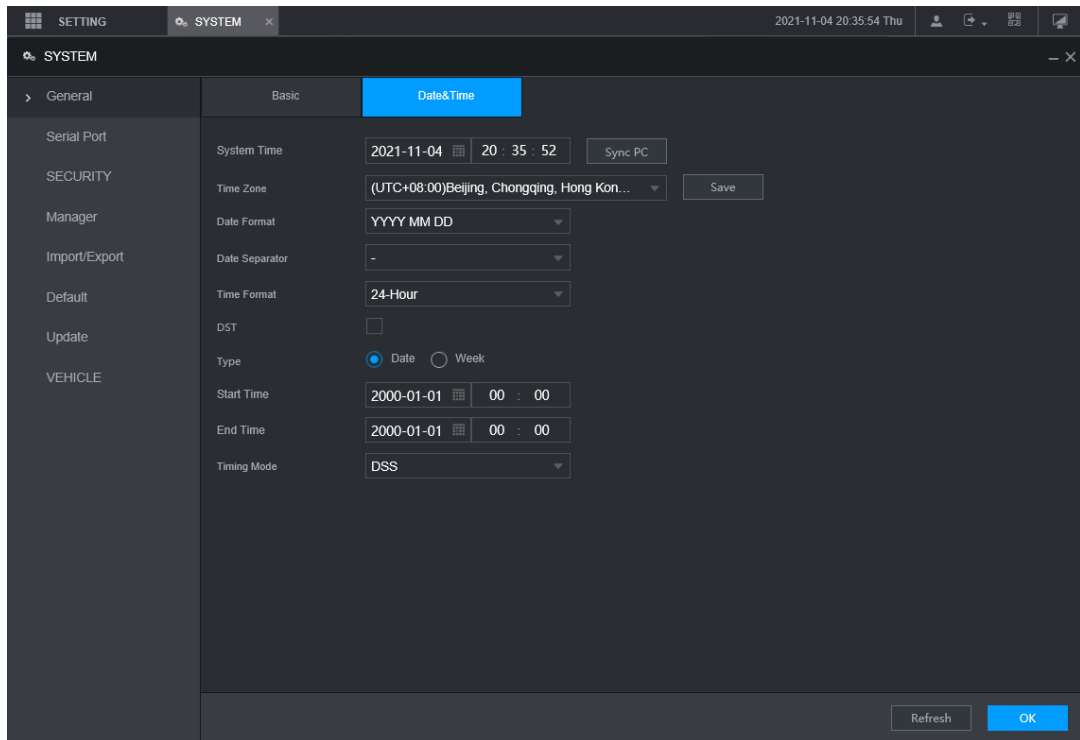

**Step 2** Configure Serial port parameters. See Table 3-4.

Table 3-4 Date and time settings parameters description

Parameter	Description
Date format	Select a date format.
Time format	Select a time format.
Time zone	In the <b>Timing Mode</b> list, if <b>GPS</b> or <b>NTP</b> is selected, configure this parameter. Configure the Time zone that the Recorder is at.
System Time	Displays the current system date and time.
Sync PC	Click <b>Sync PC</b> to sync the system time with the PC from where you login the web interface.
DST	The DST is applied in some countries or regions. Select the <b>DST</b> check box if it is applied where the Recorder is located
DST Type	
Start Time	
End Time	2. According to the local regulations, configure the type, begin time and end time for the DST.
Timing Mode	Select a timing mode, including DSS, GPS, and NTP. The default selection is NTP <ul style="list-style-type: none"> <li>● <b>DSS</b>: The system time syncs with DSS platform.</li> <li>● <b>GPS</b>: The system time syncs with satellite.</li> <li>● <b>NTP</b>: The system time syncs with NTP server that you configured.</li> </ul>
Server Address	In the <b>Timing Mode</b> list, if <b>NTP</b> is selected, configure this parameter. After configuring NTP server, the Recorder syncs time with NTP server.
Manual Update	3. In the <b>Timing Mode</b> list, select <b>NTP</b> to enable the NTP timing function. 4. Configure parameters.

Port	<ul style="list-style-type: none"> <li>◇ Server Address: Enter IP address of NTP server.</li> <li>◇ Manual Update: Click <b>Manual Update</b> to sync the Recorder time with NTP server.</li> </ul>
Interval	<ul style="list-style-type: none"> <li>◇ Port: The system supports TCP protocol only and the default setting is 123.</li> <li>◇ Interval: Enter the interval that you want the Recorder to sync time with the NTP server. The maximum value is 65535 minutes.</li> </ul>

Step 3 Click **OK**.

## 3.6 Configuring Remote Recorders

This section describes how to add cameras to channels. Connect the IPC to the Ethernet port on the rear panel of the Recorder. You can use a holder or tie strap to fix the port.

### 3.6.1 Initializing the Remote Recorder

Only the initialized remote Recorder can be added. If the remote Recorder that you want to add has been initialized, ignore this section.

#### Preparation

Make sure the remote Recorder supports initialization.

#### Procedure

Step 1 Select **SETTING > CAMERA > Camera List**.

The **Camera List** interface is displayed. See Figure 3-12.

Figure 3-12 Camera List

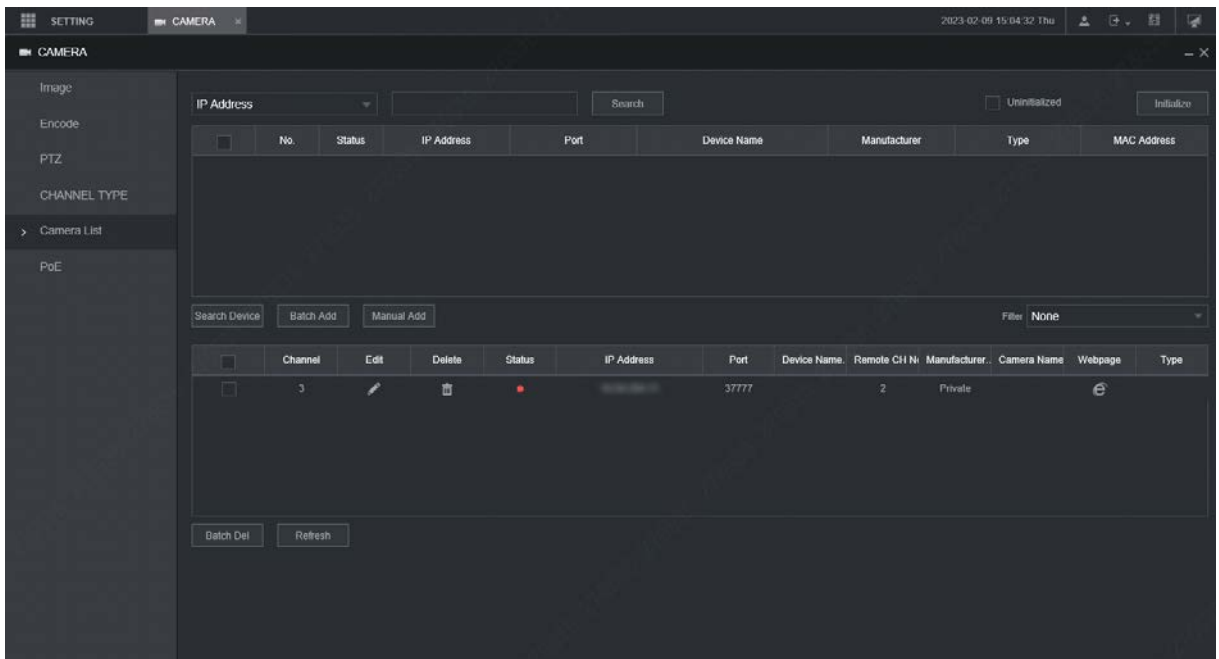

Step 2 Click **Search**.

The searched recorders are displayed.

**Step 3** Click the **Uninitialized** check box.

The uninitialized recorders are displayed.

**Step 4** Click the check box the uninitialized Recorder, and then click **Initialize**.

The **Enter Password** interface is displayed. See Figure 3-13.

Figure 3-13 Enter password interface

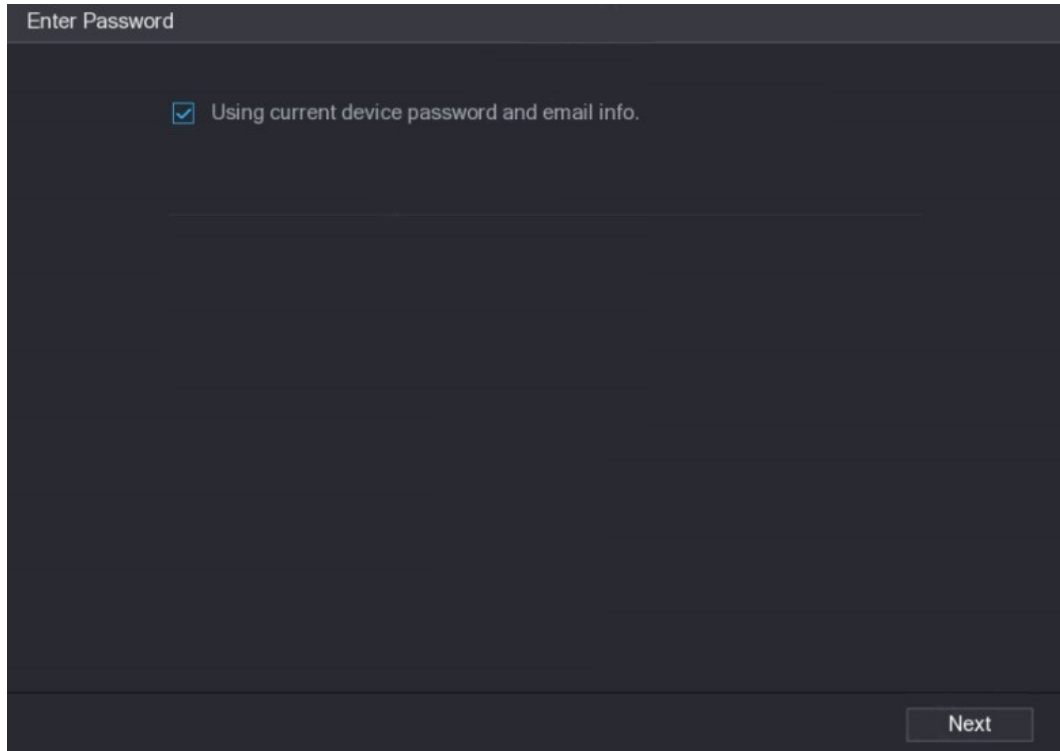

**Step 5** Configure the password by either of the following two ways.

- Using current Recorder password and email info. Select the **Using current device password and Email** check box, and the remote Recorder uses the password and email info of the Recorder.
- Manually configure password for remote Recorders.
  - 1) Clear the Using Current Recorder password and Email check box.  
The password setting interface is displayed. See Figure 3-14.



Figure 3-14 Set a password

Enter Password

Using current device password and email info.

User admin

Password

Use a password that has 8 to 32 characters, it can be a combination of letter(s), number(s) and symbol(s) with at least two kinds of them.(please do not use special symbols like ' ' ; ; & )

Confirm Password

Next

- 2) In the **Password** box, enter the new password and enter it again in the **Confirm Password** box. Click **Next**.

The password setting interface is displayed. See Figure 3-15.

Figure 3-15 Password protection

Password Protection

Email Address

To reset password, please input properly or update in time

Back Next Skip

- 3) Set password protection.
  - ◇ Click the **Email Address** check box, and then enter the email address. Click **Next**.
  - ◇ Click **Skip** if you do not want to set up password protection.

The **Modify IP** interface is displayed.

Figure 3-16 Modify IP interface

Modify IP

Checked Device No.: 1

DHCP

STATIC

IP Address: [192.168.1.100]

Subnet Mask: [255.255.255.0]

Default Gateway: [192.168.1.1]

Username: admin

Password: [ ]

Incremental Value: 1

1	Serial No.	IP Address
1		192.168.1.100

OK Cancel

**Step 6** The Recorder starts initializing Recorder. After initialization is completed, see Figure 3-17.  
Figure 3-17 Initialization completed

Device Initialization

Device Initialization Finished

[Progress Bar]

1	IP Address	Serial No.	Results
1	192.168.1.100	0000000000000000	Initialize:Succeed Modify IP:Succeed

Finished

**Step 7** Click Finished.

### 3.6.2 Adding a Remote Recorder

You can add a remote Recorder manually or by search.

**Step 1** Select SETTING > CAMERA > Camera List.

The **Camera List** interface is displayed.

**Step 2** Adding a remote recorder.

- Search and Add
  1. Click Search, the searched Recorders are displayed.
  2. Double-click on an IP address or select the check box of a Recorder, and then click Add.  
The Recorder displays in the added Recorder area.
- Manual Add
  1. Click Manual Add.  
The **Manual Add** interface is displayed. See Figure 3-18.

Figure 3-18 Manual add

2. Configure more settings. See Table 3-5.



The parameters might be different depending on the model you purchased.

Table 3-5 Manual add parameters description



Parameter	Description
Channel	The channel number of the remotely connected device. You can only select a channel that has not added remote devices.
Manufacturer	Select a manufacturer according to the actual situation. Parameters might vary by manufacture. Follow specific parameters on the interface.
IP address	Enter the IP address of remote Recorder.
TCP Port	TCP service port. The default setting is 37777. You can configure this parameter according to your actual situation.
RTSP Port	Enter RTSP Port number of remote Recorder. The default setting is 554.  This must be set up when you select Onvif as the Manufacturer.
HTTP Port	Enter HTTP Port number of remote Recorder. The default setting is 80.  This must be set up when you select Onvif as the Manufacturer.
Username	Enter the user name and password to login to the remote Recorder
Password	

Remote Channel	Select the channel number that you want to connect.
Decode Strategy	Select decode strategy from real-time, normal and fluent.
Encryption	Select "Encryption" and the system will encrypt and protect the transmitted data.  <ul style="list-style-type: none"> <li>• This must be set up when you select Onvif as the Manufacturer.</li> <li>• This function requires the IPC to enable HTTPS.</li> </ul>
Service type	This must be set up when you select Onvif or Custom as the Manufacturer When selecting different manufacturers, the service types are different. Select the service type based on your needs.

3. Click **OK**.

The Recorder displays in the added Recorder area.



- If the remote Recorder that you want to add has the same IP address and TCP port with the existing added Recorder, then this Recorder cannot be added.
-  indicates connection is successful;  indicates connection failed.
- To delete an added Recorder, select it, and then click **Delete**; to modify the information of an added Recorder, click  or double-click the Recorder.

### 3.6.3 Modifying IP Address of Remote Recorder

You can modify the IP address of remote Recorder according to your network plan.

**Step 1** Select SETTING > CAMERA > Camera List.

The **Camera List** interface is displayed.

**Step 2** In the **Added Recorder** list, click  corresponding to a Recorder.

The **Edit** interface is displayed. See Figure 3-19.

Figure 3-19 Edit

Channel: 3  
Manufacturer: Private  
IP Address: [blurred]  
TCP Port: 37777 (1~65535)  
User Name: admin  
Password: [dots]  
Remote Channel: 1  
Decoder Buffer: Default

OK Cancel

**Step 3** Enter the user name and password of remote Recorder.



The system automatically obtains the user name, which is **admin** by default.

**Step 4** Enter the IP address of remote Recorder according to your network plan.

**Step 5** Click **OK**.

After modification, the new IP address is displayed in the added Recorder area.

## 3.7 Configuring Record

The record mode is consisted of manual mode and auto mode. You can also enable or disable the snapshot function.

- Auto: The recording starts automatically according to the record type and recording time as configured in the recording schedule.
- Manual: Keep general recording for 24 hours for the selected channel.



Manual recording operation requires the user have the permission to access **STORAGE** settings.

Check to ensure the HDD installed in the Recorder has been formatted properly.

**Step 1** Select **SETTING > STORAGE > Record Mode**.

The **Record Mode** interface is displayed. See Figure 3-20.

Figure 3-20 Record Mode

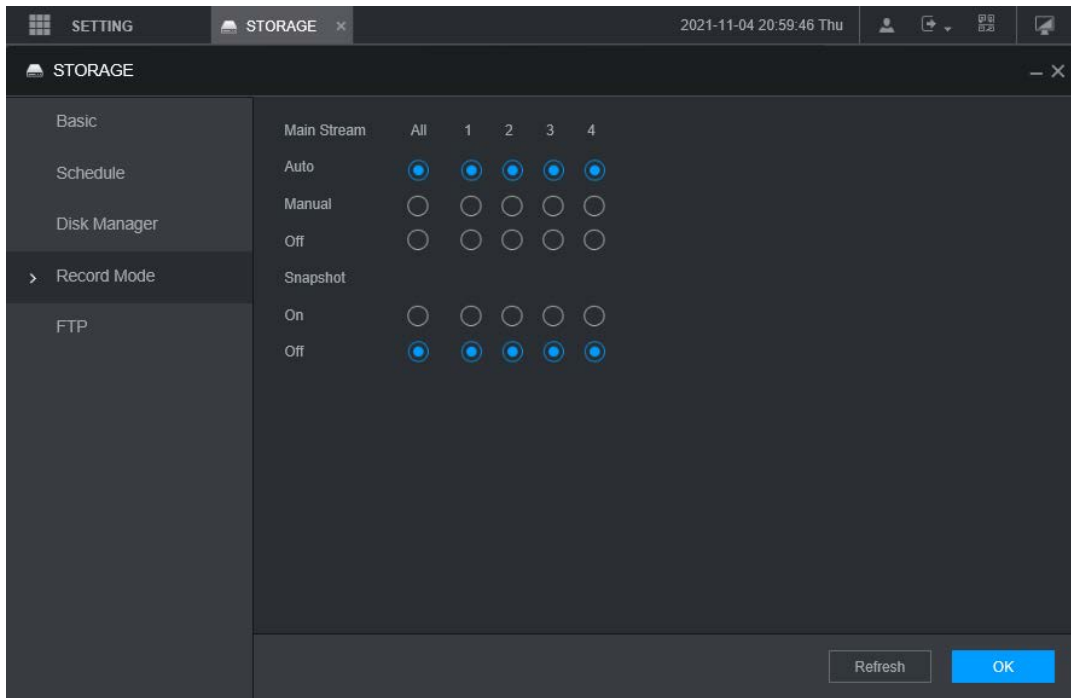

**Step 2** Configure Serial port parameters, for the detailed description, see Table 3-6.

Table 3-6 Record Mode parameter description

Parameter	Description
Channel	Displays the channel number. You can select one or several channels or select <b>All</b> .
Status	Indicates the recording status of corresponding channels. The choices include Auto, Manual, Enable, and Stop. <ul style="list-style-type: none"> <li><input checked="" type="radio"/>: Selected</li> <li><input type="radio"/>: Not selected</li> </ul>
Auto/Manual/Off	Select the recording mode, including Manual, Auto, and Stop. <ul style="list-style-type: none"> <li>Manual: Top priority. When the <b>Manual</b> check box is selected, the system keeps general recording for 24 hours for the corresponding channel.</li> <li>Auto: The system starts recording according to the record type (such as general alarm, motion detect, and system alarm) and recording time.</li> <li>Off: Do not record.</li> </ul>
Enable/Off	Enable or disable the scheduled snapshot for the corresponding channels.

**Step 3** Click **OK**.

## 3.8 Storage Plan

### 3.8.1 Configuring Recording Schedule

All channels record 24 hours by default. You can configure the record type and recording time as needed.

#### Preparation

The auto recording function is enabled for the corresponding channel. For details, see "3.7 Configuring Record."

#### Procedure

- Step 1** Select SETTING > STORAGE > Schedule > Record.  
The **Record** interface is displayed. See Figure 3-21.

Figure 3-21 Record

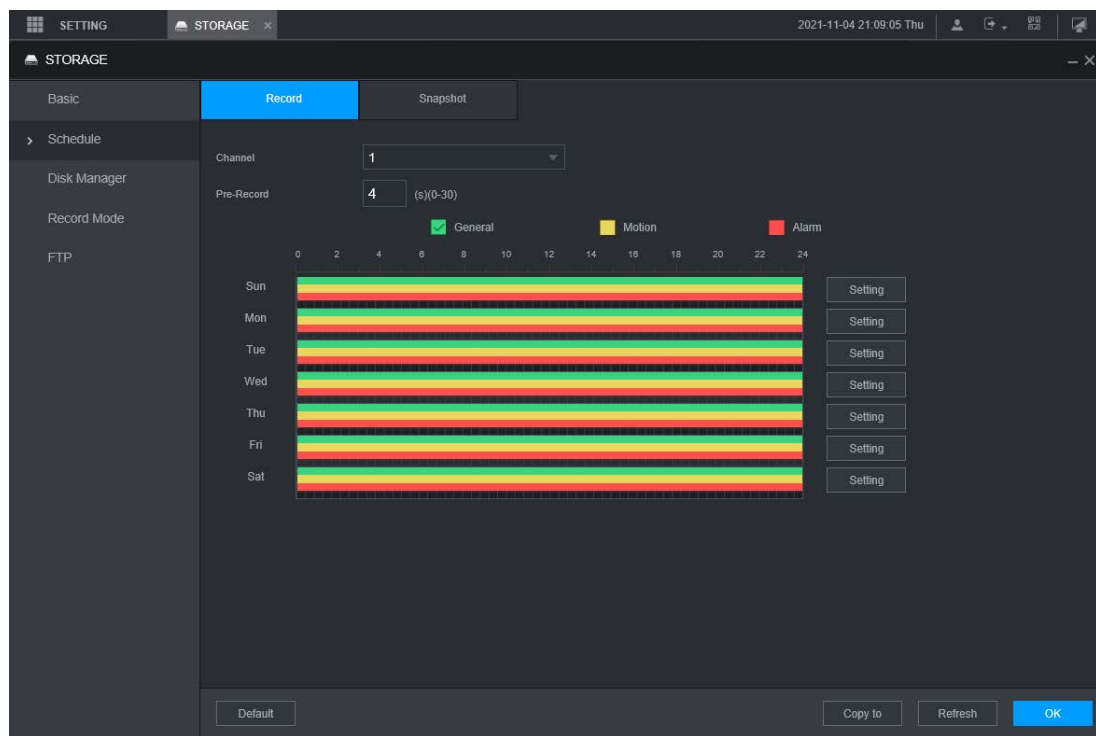

- Step 2** Configure pre-record parameters. See Table 3-7.

Table 3-7 Pre-record parameters description

Parameter	Description
Channel	Select a channel to configure the corresponding recording schedule. If you configure the same setting for all channels, select <b>All</b> .
Pre-record	Start recording from 0s to 30s before the alarm event occurs. If you enter 0 seconds, there will be no pre-recording.

- Step 3** Configure the recording time period.
- 1) Click **Setting** corresponding to the weekday.  
The **Period** interface is displayed. See Figure 3-22.

Figure 3-22 Period

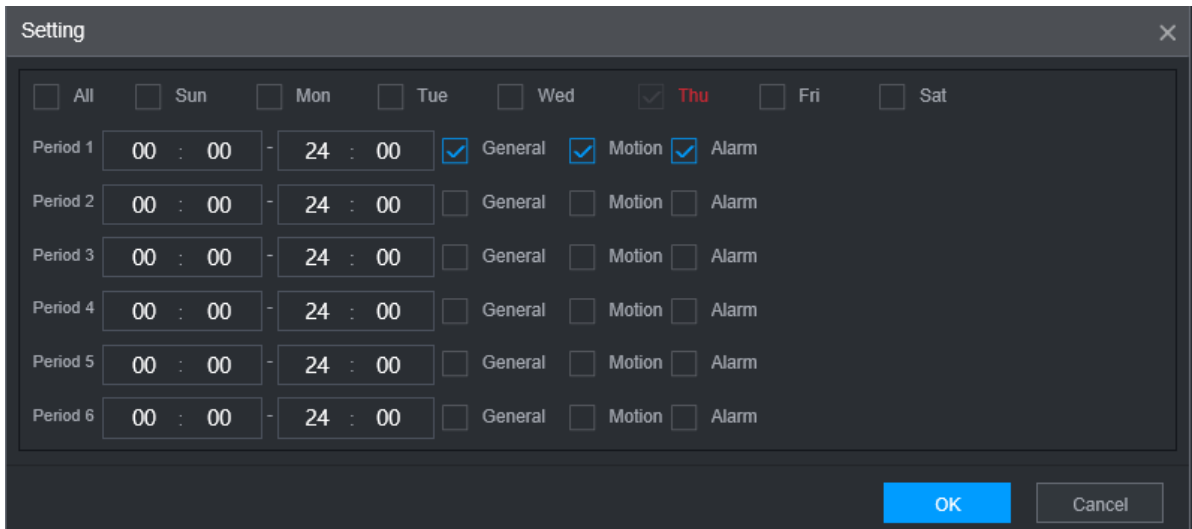

- 2) Select the record type and a weekday, and configure the period.



If the **Motion** check box and the **Alarm** check box are selected, the corresponding alarm linkage should be enabled. For example, if the alarm type is **Motion**, select **Enable Channel**, and select the recording channel.

- 3) Click **OK** to return to the **Record** interface.

**Step 4** Click **OK**.



Click **Copy** to copy the settings to other channels.

## 3.8.2 Configuring Snapshot Schedule

You can configure the storage schedule for taking the snapshot.

### Preparation

The snapshot function is enabled for the corresponding channel. For details, see "3.7 Configuring Record."

### Procedure

- Step 1** Select **SETTING > STORAGE > Schedule > Snapshot**.  
The **Snapshot** interface is displayed. See Figure 3-23.



Figure 3-23 Snapshot

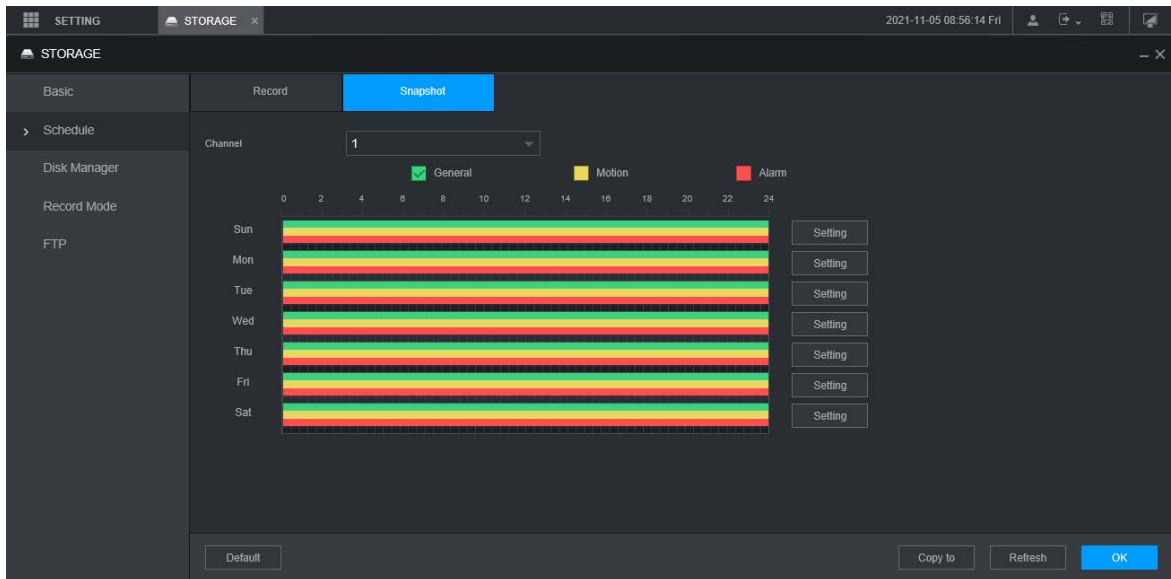

**Step 2** Configuring time period for taking snapshots.

1) Click **Setting**.

The **Period** interface is displayed. See Figure 3-24.

Figure 3-24 Period

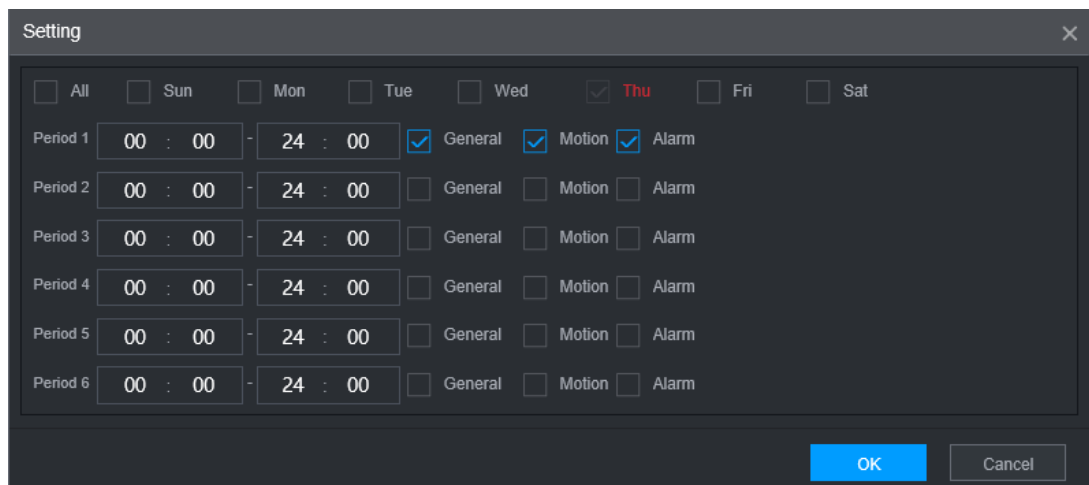

2) Select the snapshot type and weekday, and configure the period for taking snapshot.

3) Click **OK** to return to the **Snapshot** interface.

**Step 3** Click **OK**.

# 4 Function Modules Operations

Operate the Recorder on local interface or web interface. Two kinds of interface operation are similar. This section takes web interface operation for example.

## 4.1 Live

After you logged in to the web interface, the **LIVE** interface is displayed.

Figure 4-1 Live

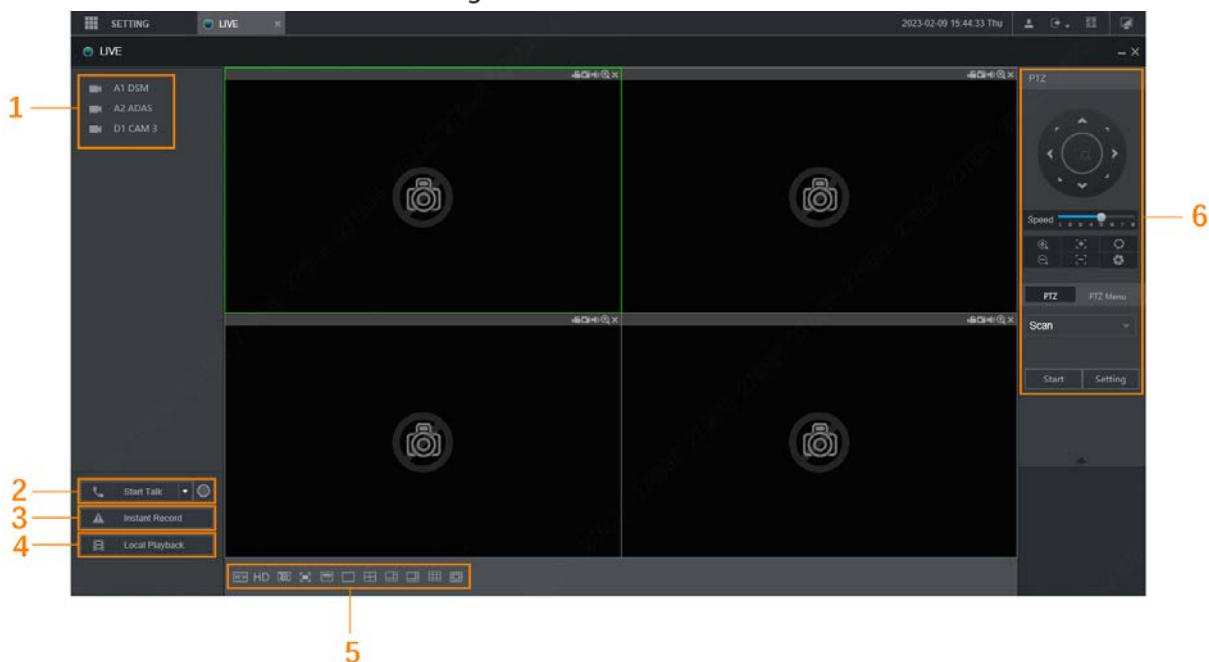





Table 4-1 Live interface parameters description

No.	Name	Description
1	Live channels	See "4.1.1 Live Channels."
2	Start Talk	See "4.1.2 Voice Talk."
3	Instant Recording	Click <b>Instant Record</b> , the recording type switches to Manual, and the icon turns to  ; click <b>Instant Record</b> again to switch the record type back to Auto.  This function is only supported by main stream.
4	Local Playback	Plays back the video file (.dav) stored on the PC. Click <b>Local Playback</b> , select the video file in the pop-up dialog box, and then click <b>Open</b> to start playing back the video file
5	Window function operations	<ul style="list-style-type: none"> <li>Configure the image quality, playback fluency, full screen, vertical sync, and window split mode.</li> <li>For real-time monitoring, you can select the fluency or real-time to be the priority according to your actual requirement.</li> <li>Select  to split the live window as necessary.</li> </ul>

6	PTZ	See "4.1.3 PTZ Control."
---	-----	--------------------------

### 4.1.1 Live Channels

Display the list of monitoring channels.

Figure 4-2 Monitoring channels



### Operations in Monitoring Channels







Click any monitoring channel to display its live video. See Figure 4-3.

Figure 4-3 Live video



Table 4-2 Video monitoring window parameters description

No.	Parameter	Description
192.168.1.16_3_4101Kbps_M	Recorder information	Displays the IP address, channel number, bit stream, and stream type (M represents main stream; S represents sub stream)

	Local Record	Click this icon to start recording; click it again to stop recording.  The recorded files are stored in C:\Record Download by default. You can modify this path if needed.
	Snapshot	Click this icon to start taking snapshot.  The snapshots default storage path is C:\PictureDownload. You can modify this path if needed.
	Audio	Mute/unmute audio.
	Area zoom in	Click the icon, and then draw a box at any area to zoom in the selected part. Right-click or click the icon again to restore to the original status.
	Close	Close the live view in the window.

## Bit Rate

The system supports switching between main stream and sub stream in real-time monitoring window. See Figure 4-4.

Figure 4-4 Bit rate

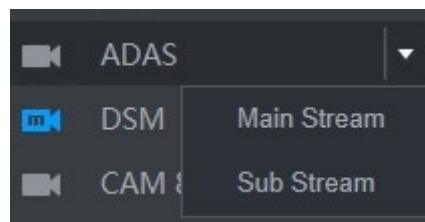

### 4.1.2 Voice Talk

You can do the two-way voice talk between the Device and Client.

Figure 4-5 Voice intercom

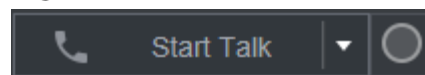

- Click **Start Talk** to enable the voice talk between the Device and Client.
- Click the drop-down list to select the voice talk mode. Available options include: DEFAULT, PCM, G711a, and G711u.

After enabling voice talk, the **Start Talk** icon turns to **End Talk**. Click **Stop Talk** if you want to end the talk.

### 4.1.3 PTZ Control

You can perform the operations through PTZ control panel, such as PTZ directions, speed, zoom, focus, and iris. See Figure 4-6.



- PTZ support rotating Recorder toward eight directions, up, down, left, right, left up, right up, left down, right down.
- Speed function controls the movement speed. The larger the value is, the faster the PTZ moves.
- Click / to display or hide the **PTZ** settings and **PTZ** menu functions.

Figure 4-6 PTZ Console



#### 4.1.3.2 PTZ

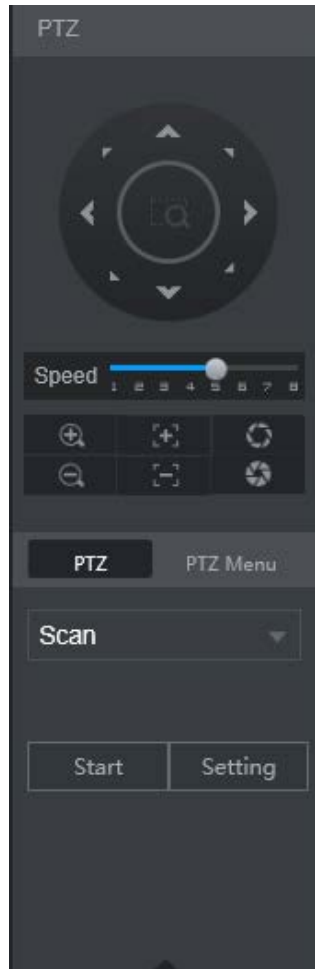

You can configure scan, preset, tour, pattern, and auxiliary functions. For details, see Figure 4-7 and Table 4-3.

Figure 4-7 PTZ



Table 4-3 PTZ functions settings parameters

Parameter	Description
Scan	<p>After setting up scan, the camera automatically scans the configured left border and right border.</p> <ol style="list-style-type: none"> <li>In the <b>PTZ Setup</b> list, select <b>Scan</b>, and then click <b>Setup</b>. Two buttons of <b>Set the left border</b> and <b>Set the right border</b> are displayed.</li> <li>Through the PTZ control panel, move the camera to the left border that you want and click <b>Set the left border</b>; move the camera to the right border that you want and click <b>Set the right border</b>. Configuration finished.</li> <li>Click <b>Start</b> to start scanning; click <b>Stop</b> if you want to end scanning.</li> </ol>
Preset point	<p>You can quickly move the PTZ camera to the configured presets after configuration. In the PTZ setup list, select Preset, and then move the camera to the direction that you want to monitor.</p> <ol style="list-style-type: none"> <li>Click <b>Preset</b>, and control the PTZ console to turn the camera to the target monitoring direction.</li> <li>In the Preset box, enter the preset value.</li> <li>Click <b>Add</b> to complete adding preset.</li> <li>In the Preset box, enter the preset value, and then click <b>Go to</b>, the camera moves to the location of preset. Click <b>Del</b> to delete the preset.</li> </ol>
Calling Tours	<p>The PTZ camera repeats performing tours among the configured presets after configuration.</p> <ol style="list-style-type: none"> <li>Click <b>Tour</b> and set up the value of the tour</li> <li>Click <b>Add</b>, and then enter the preset value</li> <li>Click <b>Add Preset</b> or <b>Del Preset</b> to add or delete the presets</li> </ol> <p> You can do this repeatedly to add presets to delete presets from the tour</p> <ol style="list-style-type: none"> <li>Enter the tour value, and then click <b>Start</b>. The camera starts rotating according to the configured tour. Click <b>Del</b> to delete the tour.</li> </ol>

Touring pattern	<p>The PTZ camera repeats movement according to the configured patterns. The operation records include the information such as the manual operations and focus adjustment</p> <ol style="list-style-type: none"> <li>1. Click <b>Pattern</b> and enter the pattern value</li> <li>2. Click <b>Add</b>. Two buttons of <b>Start Rec</b> and <b>Stop Rec</b> are displayed.</li> <li>3. Click <b>Start Rec</b>. Then operate the PTZ control panel to adjust the camera with regard to the parameters such as monitoring direction, zoom, and focus.</li> <li>4. Click <b>Stop Rec</b> to complete the touring pattern setting.</li> <li>5. Enter the pattern value, and then click <b>Start</b>. The camera moves according to the configured patterns. Click <b>Stop</b> to stop the pattern.</li> </ol>
Pan	In the <b>PTZ Setup</b> list, Click <b>Pan</b> , and then click <b>Start</b> . The camera keeps rotating with 360° horizontally. Click <b>Stop</b> to stop rotating.
Light	<p>Controls the light of external Recorder through RS-485 command. To use this function, make sure it is supported on the external Recorder</p> <p>In the <b>PTZ Setup</b> list, Click <b>Light</b>. Click <b>On</b> to turn on the light, and click <b>Off</b> to turn off the light.</p>
Using Flip function	Select and click <b>Flip</b> if you want to flip display the video image
Reset	Click <b>Reset</b> to reset the PTZ
POFE	<p>If you select this, PTZ will automatically turn to certain fixed position after device on.</p>  <p>To make this function work, you need to configure preset 2 first, and then turn on the device and enable POFE, PTZ will turn to preset 2 position.</p>
PONE	<p>If you select this, PTZ will automatically turn to certain fixed position after device off.</p>  <p>This function needs to configure preset 65 beforehand, after choosing this and turn off device, PTZ will turn to that preset position.</p>

### 4.1.3.3 PTZ Menu

After the PTZ menu is turned on, it displays on the monitoring window. You can configure the settings for the options such as camera, PTZ, and system, and apply the settings through arrow buttons and **Save** button.



This function is supported only on the camera with PTZ menu function.

**Step 1** Turn on the camera monitoring screen.

**Step 2** On the PTZ control interface, click the **PTZ Menu** tab.

The **PTZ Menu** is displayed. See Figure 4-8. For details, see Table 4-4.

Figure 4-8 PTZ menu

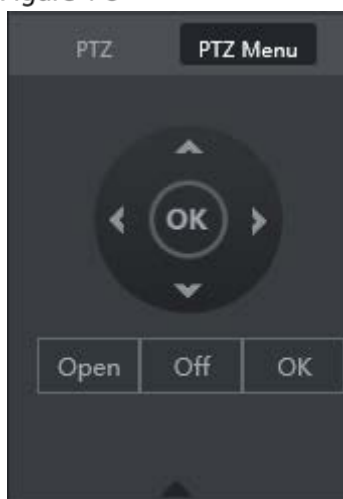



Table 4-4 PTZ menu parameters description

Parameter	Description
	Up and down buttons: Select the item that is pointed.
	Left and right buttons: When the item is pointed, perform configurations to the item.
Open	Click <b>Open</b> to turn on the <b>PTZ menu</b> that is displayed on the monitoring window.
Off	Click <b>Off</b> to turn off the <b>PTZ menu</b> .
OK	The <b>OK</b> button provides the following functions. <ul style="list-style-type: none"> <li>● If there is sub-menu for an item, click <b>OK</b> to enter the sub-menu.</li> <li>● Move the pointer to <b>Return</b>, and then click <b>OK</b> to return to the higher level menu.</li> <li>● Move the pointer to <b>Exit</b>, and then click <b>OK</b> to exit the menu.</li> </ul>

**Step 3** Click **On**.

The OSD menu is displayed on the monitoring screen.

Table 4-5 OSD menu parameters description

Parameter	Description
Camera	Move the pointer to <b>Camera</b> , and then click <b>OK</b> to enter the sub-menu of <b>Camera</b> . You can configure the camera parameters such as image, exposure, backlight, white balance, day & night, zoom, and focus.
PTZ	Move the pointer to <b>PTZ Setup</b> , and then click <b>OK</b> to enter the sub-menu of <b>PTZ Setup</b> . You can configure the PTZ parameters such as preset, tour, scan, pattern, pan, and reboot.
System Manager	Move the pointer to <b>System</b> , and then click <b>OK</b> to enter the sub-menu of <b>System</b> . You can configure the settings such setting analog PTZ, restoring factory default, and viewing camera version and PTZ version.
Back	Move the pointer to <b>Return</b> , and then click <b>OK</b> to return to the higher level menu.
Exit	Move the pointer to <b>Exit</b> , and then click <b>OK</b> to exit the menu.

**Step 4** Click **Off** to turn off the PTZ menu.



## 4.2 Record Playback

On the **SEARCH** interface, you can play back or download video recording files.

On the main web interface, click **SAERCH**.

Figure 4-9 Playback

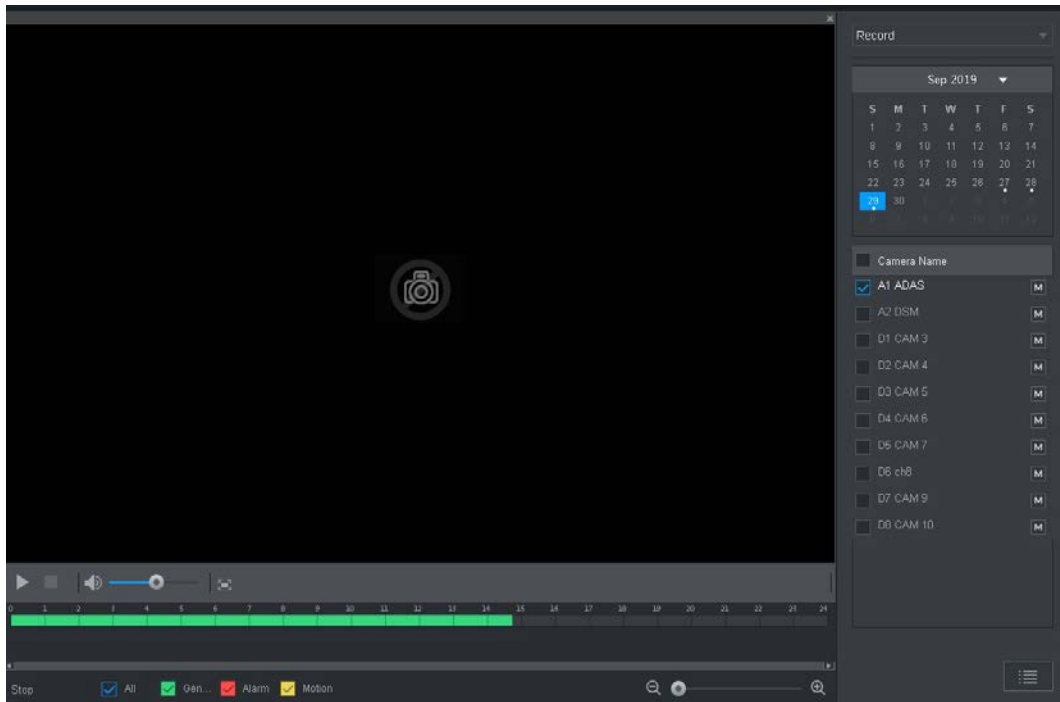

















Table 4-6 Playback function bar

No.	Function	Description
1	Playback control bar	See "4.2.1 Playback Control Bar."
2	Volume adjustment	Controls playback volume, including: <ul style="list-style-type: none"> <li>, means mute.</li> <li>, means not mute, and the volume can be adjusted.</li> </ul>
3	Full screen button	To play the video recording in full screen.
4	Video editing	Captures and saves certain video sections.
5	Sync	With <b>Sync</b> selected, when you click in the progress bar to play back the recordings, the playback time of other channels will sync with the selected channel in the following ways: <ul style="list-style-type: none"> <li>If the playback time of other channels is before the time of the selected channel, other channels will speed up the playback till synced with the selected channel.</li> <li>If the playback time of other channels is after the time of the selected channel, other channels will pause to wait till synced with the selected channel.</li> </ul>
6	Record type selection	The record types include Regular, MD, and Alarm. You can select the type as needed.

7	Time bar	Move the slider or click   to adjust the time bar.
8	Playback type	To select the playback type. Only record playback is supported at present.
9	Date selection	Click to select the date the recording on which you want to play back.
10	Camera name	You can set the cameras to focus on.  You can select up to 4 cameras.
11	File list	In the file list, you can play back the recordings by file name, download video recordings by file name or time, and verify the completeness.



## 4.2.1 Playback Control Bar

Table 4-7 Playback control bar

Icon	Function	Description
	Play	When this icon displays, it means the video is paused or not being played. You can click this icon to play the video.
	Stop	Click this icon to stop playback.
	Backward playback	Click this icon to play the video recording backward.
	Previous frame	Click this icon to jump to the previous frame.  You need to pause the playback before using play by frame.
	Next frame	Click this icon to play the next frame.  You need to pause the playback before using play by frame.
	Slow playback	Click this icon to adjust the slow playback speed. Click  to start slow playback.
	Fast playback	Click this icon to adjust the fast playback speed. Click  to start fast playback.

## 4.2.2 Playing Back Video Recordings

You can play back video recordings by time or file name. During playback, you can conduct the following operations.

- In the channel window, click  at the upper right corner and select the area you want to enlarge. The area is enlarged. Click this icon again or right-click in the window to exit.
- Click  at the upper right corner to take a snapshot.
- Click  at the upper right corner to close playback.

## 4.2.2.1 Playing Video Recordings by Date

Step 1 Select the date for searching for the video recordings, and set the corresponding channel as needed.

Step 2 Select a date with video recordings and the channel window, and then select the record type.

Figure 4-10 Record type



Step 3 Click  to start playing back video recordings.

## 4.2.2.2 Playing Video Recordings by File Name

Step 1 Select the date for searching for the video recordings, and set the corresponding channel as needed.

Step 2 Select a date with video recordings and the channel window.

Step 3 Click File list.

The video recordings are displayed in the list.

Figure 4-11 File list

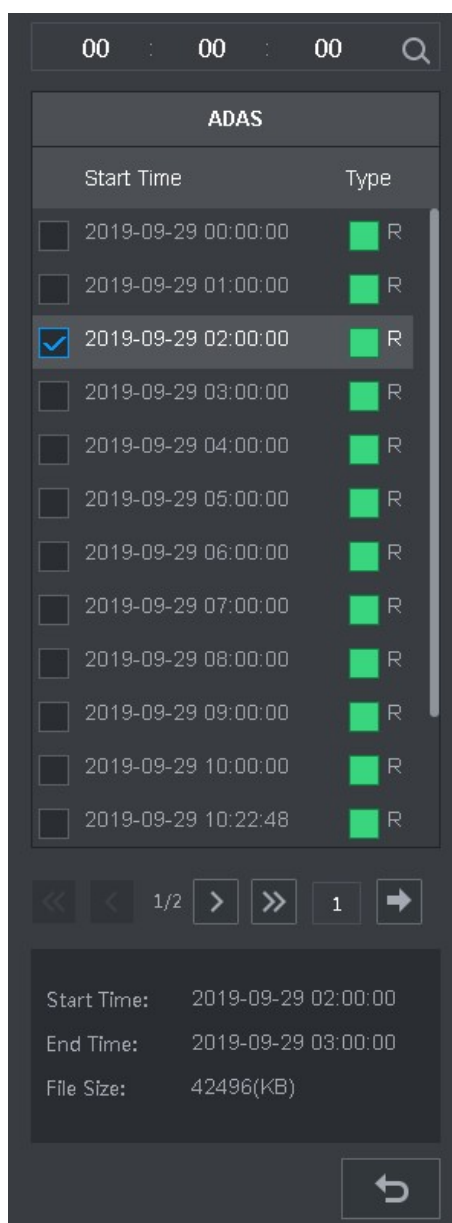

**Step 4** Set the start time of the file to be searched for, and then click . The recording files are displayed.

**Step 5** Double-click the video recordings to start playback.





### 4.2.3 Clipping Recording File

You can clip sections of video recordings and save to the PC.

**Step 1** Search for the video recordings that you want to clip by using the calendar and timeline.

**Step 2** Select the channel number.

**Step 3** Clip the video by either of the following ways.

- Method A: Click , and the  and  sliders appear at the two ends of the timeline. Move the sliders to the proper time points, and then click  to clip

- and save the section between the time points.
- Method B: In the text box shown below, enter the start time and end time, and then click  to clip and save the section during this period.

Figure 4-12 Clip and save



The system displays a downloading progress bar. After the download is completed, the clipped video files are saved in the "RecordDownload" folder by default. You can also change the path as needed.

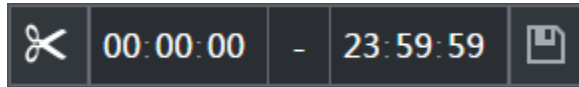

Click  to stop downloading the recordings.

## 4.3 Viewing Alarm Info

You can view the alarm information during a fixed period.

- Step 1** On the main web interface, select **ALARM > Alarm Info**.
- Step 2** Select **Type** to set the alarm type to be searched for, including All, Motion Detect, Video Loss, Tampering, Abnormality, Local and Smart Alarm.
- Step 3** Set the start time and end time.
- Step 4** Click **Search**. Alarm information in the set type during the set period is displayed.

Figure 4-13 Alarm info (2)

No.	Log Type	Log Time	Details
1	Reset GPS	2019-09-27 23:25:02	
2	Reset GPS	2019-09-27 23:25:02	
3	Net Disconnection	2019-09-27 22:25:33	
4	Net Disconnection	2019-09-27 22:25:33	
5	Net Disconnection	2019-09-27 22:25:26	
6	Net Disconnection	2019-09-27 22:25:26	
7	PoE Reset	2019-09-27 21:59:39	
8	PoE Reset	2019-09-27 21:59:39	
9	PoE Reset	2019-09-27 21:59:39	
10	PoE Reset	2019-09-27 21:59:39	
11	PoE Reset	2019-09-27 21:59:39	

- Step 5** Click **Backup** to back up the obtained alarm information to a local directory.



You need to install relevant controls before backup.

# 5 System Settings

You can set up system information following instructions on the Local interface or web interface. This section introduces the web interface instructions. The Local interface is similar and would not be elaborated here.



- Some functions can only be configured on the Local interface. The actual interface shall prevail.
- Some functions are not used in actual operations, so they are not described in detail in the document.
- In this section, when you have configured the settings for a channel, click **Copy** to apply the settings to other channels. Click **Refresh** to display the latest configuration. Click **Default** to restore to factory default settings.

## 5.1 Configuring Alarm Event Settings

Alarm information settings include the setting of video detection, alarm input, abnormality and alarm output.

### 5.1.1 Configuring Video Detect Settings

Video detection includes motion detection, video loss, and tampering. This function detects the abnormal changes and triggers alarms.

#### 5.1.1.1 Configuring Motion Detect Settings

When the moving object appears and moves fast enough to achieve the preset sensitivity value, the system triggers an alarm and alarm linkage.

**Step 1** On the main web interface, select **ALARM > Video Detection > Motion Detect**.

**Step 2** Select the channel number and select **Enable** to enable the motion detect function for the channel.

**Step 3** Set MD region.

- 1) Click **Setting** behind **Region**.  
The **Setting** interface is displayed.

Figure 5-1 Region setting

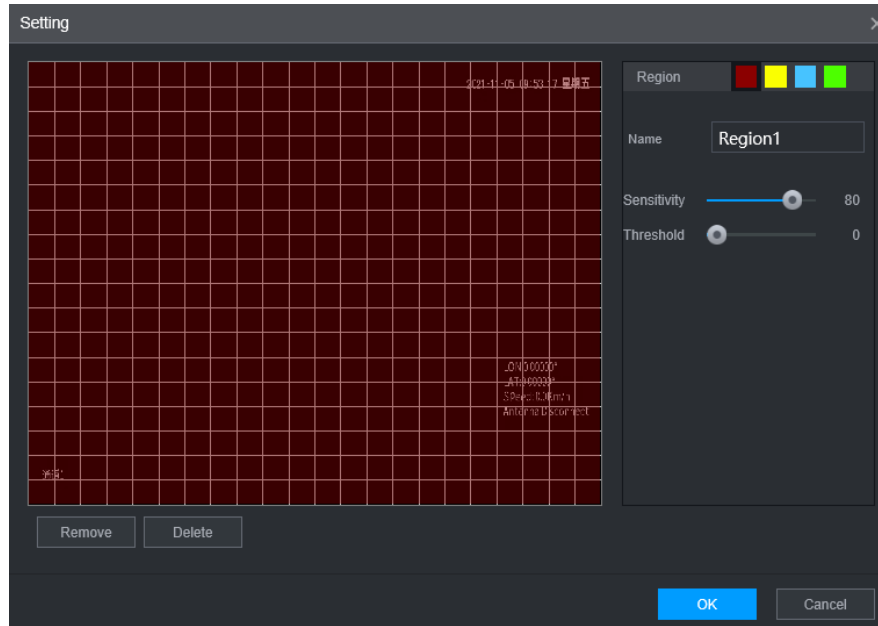

- 2) Select a region and name it.

The higher the sensitivity value is, the easier the motion detect is triggered; the lower the threshold is, the easier the motion detect is triggered. By default, the whole video image is for motion detect.



Each color represents a separate region, and you can set different motion detect regions.

- 3) Hold down the left button of the mouse, drag to select the region to be detected, and set up its sensitivity and threshold value.





Channel alarm events: As long as any one of the four regions triggers alarm, the channel that houses the region will give alarm.

- 4) Click **OK**.

**Step 4** Configure alarm linkage parameters.

Table 5-1 Alarm linkage parameters

Parameter	Description
Delay	When an alarm ends, the alarm recording will stop after a period of delay.
Alarm output	Connect with an alarm device (such as an alarm light or siren) on the alarm output interface, click <b>Setting</b> to set the alarm output device, and activate the alarm linkage output port. When an alarm event takes place, the system can trigger corresponding alarm output devices.
Latch	Click <b>Setting</b> under <b>Alarm Out</b> to set the latch. Set a length of time during which the device continues alarm output after the alarm ends.

Record channel	<p>Select the corresponding check box and set a record channel. When an alarm event occurs, the corresponding channel starts recording automatically.</p>  <p>Two more conditions must be satisfied before recording function works:</p> <ul style="list-style-type: none"> <li>• Motion detect recording is enabled.</li> <li>• Auto recording is enabled.</li> </ul>
Snapshot	<p>Select the corresponding check box and set the channel. When an alarm event occurs, the corresponding channel starts capturing automatically.</p>  <p>You can also configure the frequency, size, and quality of the snapshots.</p>
Anti-dither	<p>Click <b>More</b> to set the anti-dither time.</p> <p>The system records only one event during this period.</p>
Show message	<p>Click <b>More</b>, and select the corresponding check box to trigger a pop-up message in your local host PC when an alarm event occurs.</p>
Buzzer	<p>Click <b>More</b>, and select the corresponding check box to trigger a buzzer noise on the device when an alarm event occurs.</p>
Log	<p>Click <b>More</b>, and select the corresponding check box to enable the device to create a local alarm log when an alarm event occurs.</p>
Send email	<p>Click <b>More</b>, and select the corresponding check box. When an alarm event occurs, the system sends email to the specified mailbox.</p>  <p>Set your e-mail first before enabling this function. See "5.6.3Cellular."</p>

Step 5 Click **OK**.

### 5.1.1.2 Configuring Loss Detect Settings

When video loss occurs, the system triggers an alarm and configured actions.

Step 1 On the main web interface, select **ALARM > Video Detection > Video Loss**.

The **Video Loss** interface is displayed.

Figure 5-2 Video loss

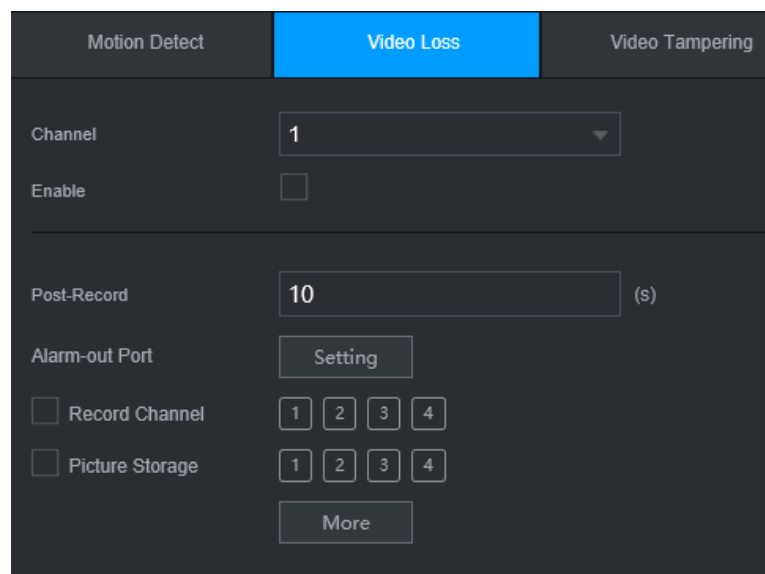



- Step 2 Select **Channel** and select **Enable** to enable the video tampering detect function for the channel.
- Step 3 Configure alarm linkage parameters.
- Step 4 Click **OK**.

### 5.1.1.3 Configuring Tampering Settings

When the camera is covered intentionally, or the video is displayed in a single color due to sunlight or other reasons, that is the monitoring cannot be continued normally, the system triggers alarm and links to the configured actions.

- Step 1 On the main web interface, select **ALARM > Video Detection > Video Tampering**. The **Video Tampering** interface is displayed.

Figure 5-3 Video Tampering

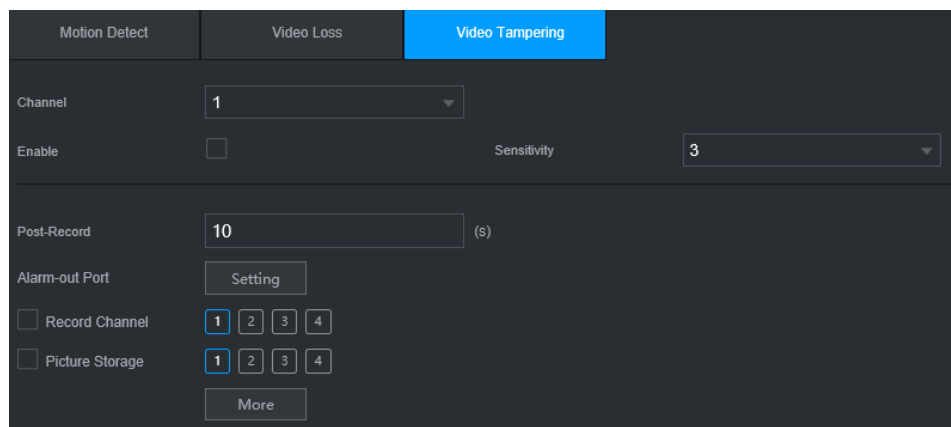

- Step 2 Select **Channel** and select **Enable** to enable the video tampering detect function for the channel.
- Step 3 Set the sensitivity of detection.  
The higher the sensitivity, the easier it is to detect a moving object, but the false alarm rate might increase.
- Step 4 Configure alarm linkage parameters.
- Step 5 Click **OK**.

### 5.1.2 Configuring Alarm Input Settings

You can select different types of input according to different sources of alarm and set up alarm output methods.

- Step 1 On the main web interface, select **ALARM > ALARM > Local**.

Figure 5-4 Alarm input

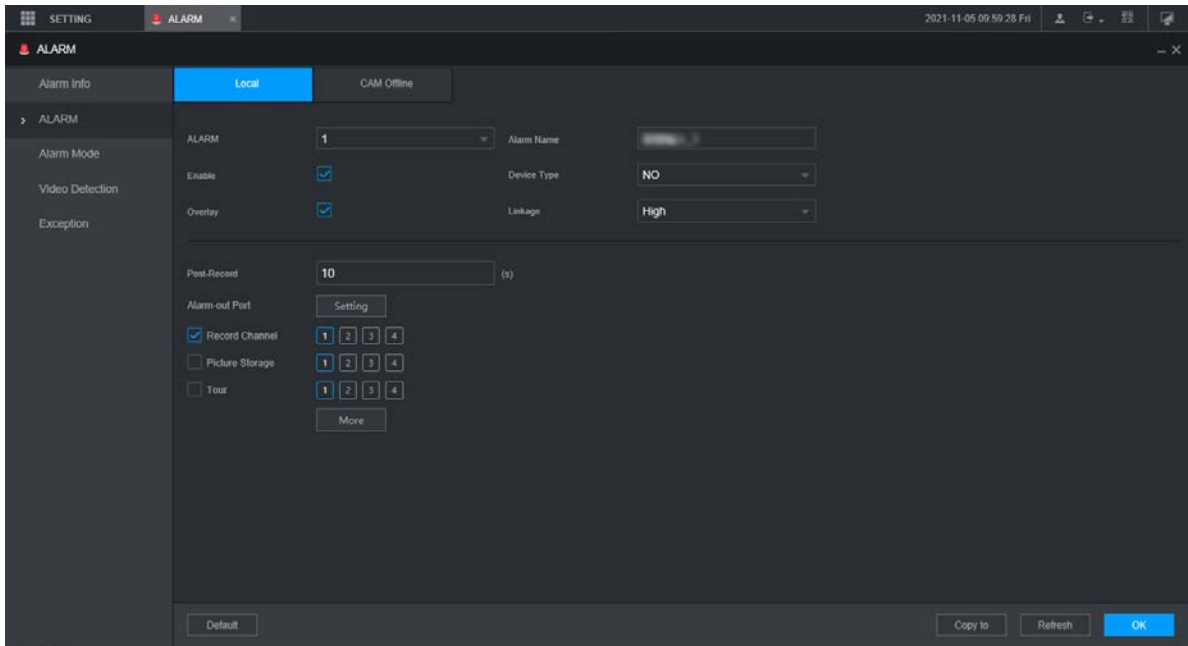

**Step 2** Click **Local** or Camera **Offline** tab as needed.

- Local: The alarm signal detected by the alarm input port on the device.
- Camera Offline: The alarm signal generated when the IP camera is offline.

**Step 3** Select the **Alarm In** channel number and select **Enable**.







For emergency alarm button, you can only select Channel **10** from the **Alarm In** drop-down list. When you press the emergency alarm button, the Recorder will receive the emergency alarm from Channel **10**.

**Step 4** Configure more settings.

Table 5-2 Alarm input parameters

Parameter	Description
Alarm name	Enter a customized alarm name.
Type	If the <b>Event Type</b> is <b>Local Alarm</b> , configure this parameter. <ul style="list-style-type: none"> <li>• <b>NO</b>: The alarm signal is disconnected normally. The alarm is triggered when alarm signal is connected.</li> <li>• <b>NC</b>: The alarm signal is connected normally. The alarm is canceled when alarm signal is disconnected.</li> </ul>
Overlay	Select the <b>Overlay</b> check box to overlay alarm names onto channel images.
Trigger	If the <b>Event Type</b> is <b>Local Alarm</b> , configure this parameter. If the alarm signal is 12V/24V voltage, select <b>High</b> as the triggering mode; if the alarm signal is ground voltage, select <b>Low</b> as the triggering mode.
Post record	When an alarm ends, the alarm recording will stop after a period of delay.
Alarm out	Connect the alarm device such as light and siren to the alarm output port. Select the corresponding check box and set an alarm output device. With the alarm linkage output port enabled, when an alarm event occurs, the system links the alarm device to trigger an alarm.

Latch	Click <b>Setting</b> under <b>Alarm Out</b> to set the latch. Set a length of time during which the device continues alarm output after the alarm ends.
Record channel	Select the corresponding check box and set a record channel. When an alarm event occurs, the corresponding channel starts recording automatically.  Two more conditions must be satisfied before recording function works: <ul style="list-style-type: none"> <li>• Alarm recording is enabled.</li> <li>• Auto recording is enabled.</li> </ul>
Snapshot	Select the corresponding check box and set the channel. When an alarm event occurs, the corresponding channel starts capturing automatically.  You can also configure the frequency, size, and quality of the snapshots.
Tour	Select the corresponding check box and the channel. When an alarm event occurs, a tour of the selected channels is displayed on the device local interface.  When the alarm linkage tour is finished, the Live interface returns to the window split mode as before the alarm occurs.
Anti-dither	Click <b>More</b> to set the anti-dither time. The system records only one alarm input event during this period.
Show message	Click <b>More</b> , and select the corresponding check box to trigger a pop-up message in your local host PC when an alarm event occurs.
Buzzer	Click <b>More</b> , and select the corresponding check box to trigger a buzzer noise on the device when an alarm event occurs.
Log	Click <b>More</b> , and select the corresponding check box to enable the device to create a local alarm log when an alarm event occurs.
Send email	Click <b>More</b> , and select the corresponding check box. When an alarm event occurs, the system sends email to the specified mailbox.  Set your e-mail first before enabling this function.

Step 5 Click **OK**.

### 5.1.3 Configuring Exception

You can configure the ways to handle the device when errors occur.

Step 1 On the main web interface, select **ALARM > Exception > Disk**.

The **Disk** interface is displayed. See Figure 5-5

Figure 5-5 Disk

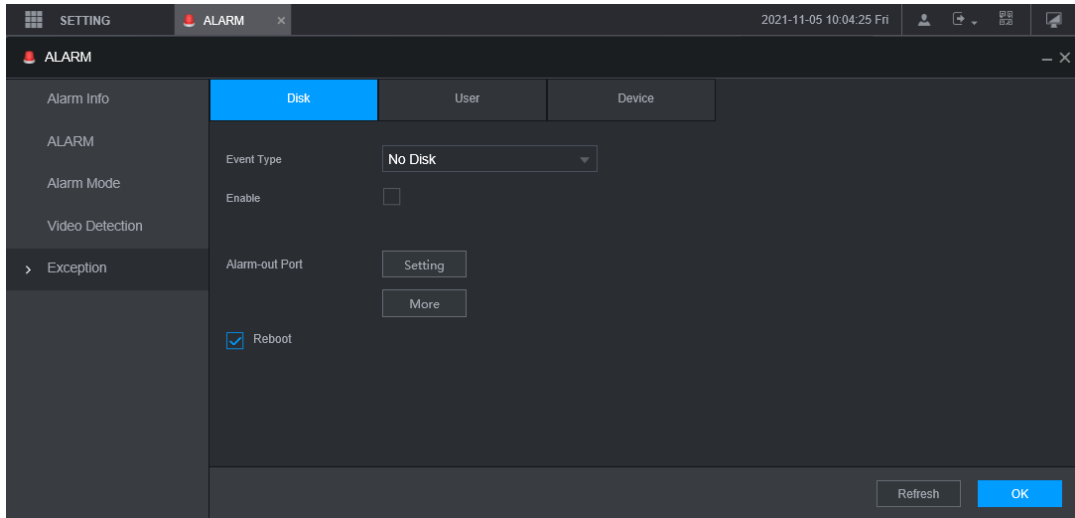

**Step 2** Select the event type, and select **Enable** to enable the handling of corresponding abnormal events.

**Step 3** Configure more settings. See Table 5-3.

Table 5-3 Abnormality setting parameters

Parameter	Description
Event type	<p>You can configure corresponding abnormal events on the following three tabs.</p> <ul style="list-style-type: none"> <li>● HDD: To set the ways to handle abnormal HDD events, including No HDD, HDD Errors, HDD No Space.</li> <li>● User: Set the ways to handle illegal login events.</li> <li>● Device: Set the ways to handle abnormal device events, including Temperature Too High, Low Battery Safety Exception, Network Security Exception, Over Speed, Low Speed, Collision, Turnover, Rapid Turn, Rapid Speedup, Sharp Brake and ACC Power Off.</li> </ul> <p> The event type might be different depending on the model you purchased, and the actual interface shall prevail.</p>
Lower Than	Select <b>Disk</b> tab, and if the <b>Event Type</b> is <b>Low Space</b> , configure this parameter. You can set the percentage of Disk remaining space. When Disk remaining space is lower than this percentage, an alarm will occur.
Login Attempt	Select <b>User</b> tab, and if the <b>Event Type</b> is <b>Illegal Login</b> , configure this parameter. The maximum number of allowed password input errors during user login. If the number of password input errors reaches this value, the user account will be locked.
Lock time	Select <b>User</b> tab, and if the <b>Event Type</b> is <b>Illegal Login</b> , configure this parameter. Set the time for locking the user account when the number of password input errors reaches the set value.
High Temperature	Select <b>Device</b> tab, and if the <b>Event Type</b> is <b>High Temperature</b> , configure this parameter. Enter the upper limit of device temperature. The alarm is triggered when the device temperature exceeds this value.
Lower Than	Select <b>Device</b> tab, and if <b>Event Type</b> is <b>Battery Low Voltage</b> , configure this

Auto	parameter.
Accumulator voltage	The supply voltage to the device from the vehicle and the percentage of available supply voltage capacity. When the vehicle is in ACC Off, and the voltage supplied to the device is less than the percentage of available capacity, the system triggers an alarm.
Max speed	Select <b>Device</b> tab, and if the <b>Event Type</b> is <b>Over Speed</b> , configure this parameter. The upper limit of vehicle speed. When the vehicle speed exceeds this value, the system triggers an alarm.
Min speed	Select <b>Device</b> tab, and if <b>Event Type</b> is <b>Low Speed</b> , configure this parameter. The lower limit of vehicle speed. When the vehicle speed is lower than this value, the system triggers an alarm.
Alarm output	Connect the alarm device such as light and siren to the alarm output port. Select the corresponding check box and set an alarm output device. With the alarm linkage output port enabled, when an alarm event occurs, the system links the alarm device to trigger an alarm.
Latch	Click <b>Setting</b> under <b>Alarm Out</b> to set the latch. Set a length of time during which the device continues alarm output after the alarm ends.
Show message	Click <b>More</b> , and select the corresponding check box to trigger a pop-up message in your local host PC when an alarm event occurs.
Send email	Click <b>More</b> , and select the corresponding check box. When an alarm event occurs, the system sends email to the specified mailbox.  Set your e-mail first before enabling this function.
Buzzer	Click <b>More</b> , and select the corresponding check box to trigger a buzzer noise on the device when an alarm event occurs.
System log	Click <b>More</b> , and select the corresponding check box to enable the device to create a local alarm log when an alarm event occurs.
Refresh	Select the <b>Refresh</b> check box. If No Disk alarm occurs, the system restarts within three minutes.

Step 4 Click **OK**.

## 5.1.4 Configuring Alarm Out Settings

You can set the alarm output type.

Step 1 On the main web interface, select **ALARM > Alarm Mode**.

The **Alarm Mode** interface is displayed.

Figure 5-6 Alarm mode

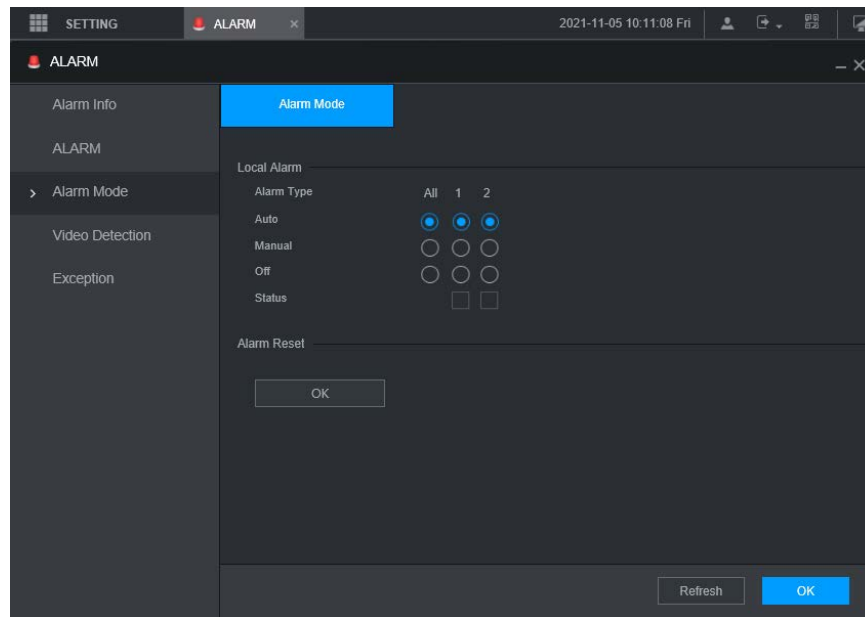

**Step 2** Select alarm type.

- Auto: After the alarm linkage is configured, when an alarm event occurs, the corresponding alarm output port triggers an alarm.
- Manual: After the alarm linkage is configured, no matter whether there is an alarm event occurs, the corresponding alarm output port triggers an alarm.
- Stop: After the alarm linkage is configured, no matter whether there is an alarm event occurs, the corresponding alarm output port never triggers an alarm.

**Step 3** Click **OK**.

Status: Indicates the status of each alarm output port.  indicates there is an alarm output, and  indicates there is not.

## 5.2 Configuring AI Settings

AI features include: Face detection and recognition, active and safe drive, license plate detection, and passenger flow counting. Only when the AI feature is enabled and set can the corresponding function take effect.

- Face Detection and Recognition
  - ◇ Face detection: The system can analyze and process the video images collected by cameras. When specific face information is detected, the system triggers alarm linkage.
  - ◇ Face matching: The system can compare the detected faces with the information in the configured face library, and trigger alarm linkage.
- Active and safe drive
  - ◇ ADAS: Advanced Driver Assistance System for detecting Lane Departure, Vehicles Too Close and Vehicle Collision pre-warnings, and alarm linkage is triggered and reported to the platform.
  - ◇ DSM: The system can analyze and process the driver behavior information collected by cameras, and detect actions such as lowering head, yawning, smoking, looking around, and not in position.

- License plate detection: Collect license plate and compare the key information with the preset detection rule and trigger an alarm once the detected behavior matches the detection rule.
- Passenger flow counting: Select the alarm channel and count the passenger flow data of the station.



- Before enabling the face matching function, enable the face detection function.
- You can enable up to 4 smart functions at the same time. (1-channel DSM, 1-channel ADAS, 1-channel face detection and 1-channel license plate detection).
- You can enable up to 2 channels of face detection and license plate detection at the same time.

## 5.2.1 Face Detection and Recognition

### 5.2.1.1 Face Detection

The system can analyze and process the video images collected by cameras, and detect whether there are faces in the video images. You can find the videos with detected faces through AI search and play back these videos.



- The installation position of the camera should be horizontal with the face as much as possible, and the overhead angle should not exceed 15 °, and the backlight scene should be avoided.
- Due to the update of the device version, the description may be inconsistent with the interface. Please refer to the actual display interface of the device for details.

#### 5.2.1.1.1 Parameter Settings

You can set up face detection parameters. When specific face information is detected, the system will trigger alarm linkage.

**Step 1** On the main web interface, select **AI > Parameters > Face Detection**.

The **Face Detection** interface is displayed. See Figure 5-7.

Figure 5-7 Face detection

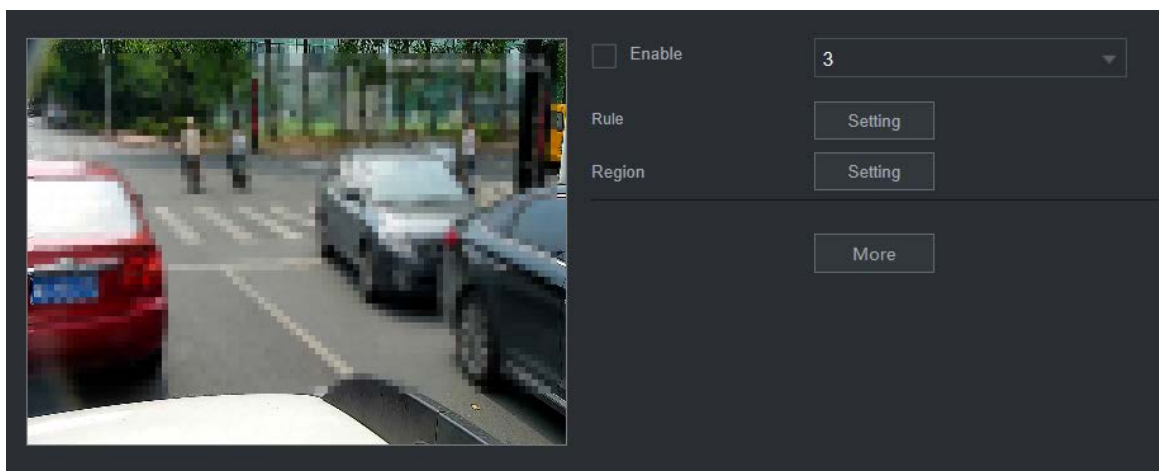

**Step 2** Select the channel number and select **Enable** to enable face detection.

**Step 3** Configure parameters. See Table 5-4 for details.

Table 5-4 Face detection parameters

Parameter	Description
Rule	<ol style="list-style-type: none"> <li>1. Click <b>Setting</b>.</li> <li>2. Set the maximum size and minimum size of the face detection region. Press and hold the left mouse button and drag four corners of the blue box to adjust the size.</li> </ol>  <ul style="list-style-type: none"> <li>• Faces smaller than the minimum size or bigger than the maximum size will not be detected.</li> <li>• The maximum size cannot be smaller than the minimum size.</li> </ul>
Region	Click <b>More Setting</b> and select <b>Region</b> . Set up the face detection region.
Buzzer	Click <b>More Setting</b> and select <b>Buzzer</b> . Activate a buzzing sound when an alarm is triggered.
System log	Click <b>More Setting</b> and select <b>System Log</b> . Record face detection log information in the system log.

**Step 4** Click **OK**.

### 5.2.1.1.2 AI Search

You can set up search parameters and filter out specific face recordings for playback.

**Step 1** On the main web interface, select **AI > AI Search > Face Detection**.

The **Face Detection** interface is displayed.

Figure 5-8 Face Detection

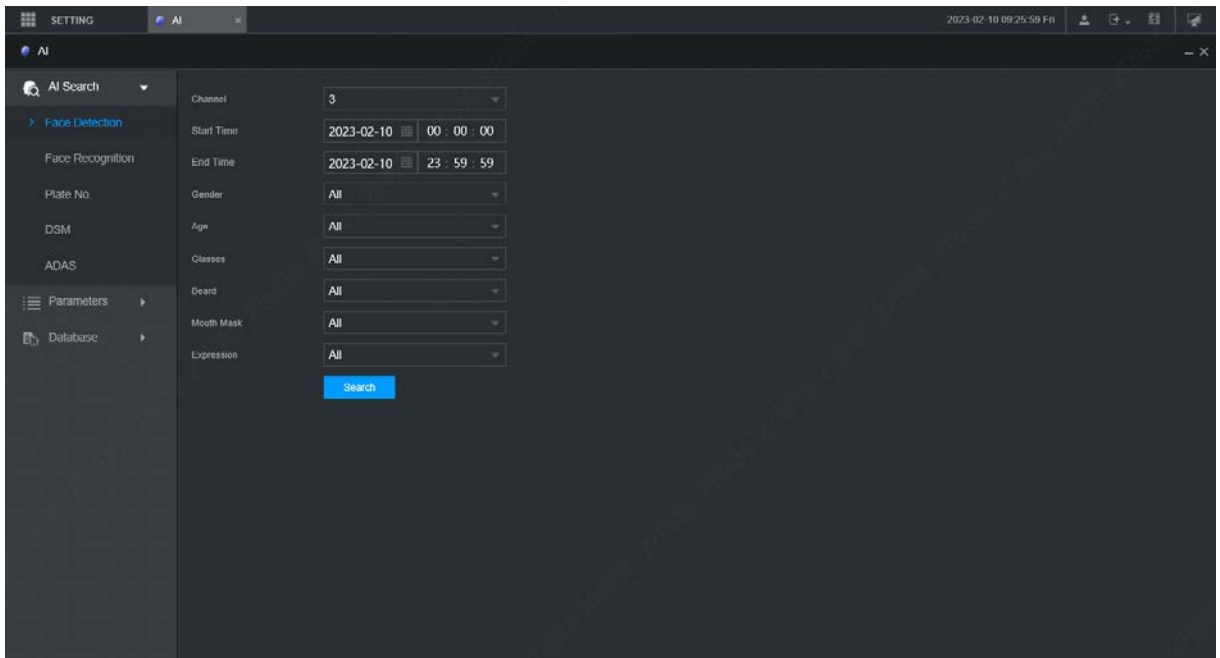

**Step 2** Select the channel, start time and end time, and select face detection details (such as gender, age, glasses, beard, mask and face) as needed.

**Step 3** Click **Search**.

The search results are displayed. See Figure 5-9.



Figure 5-9 AI search result (1)

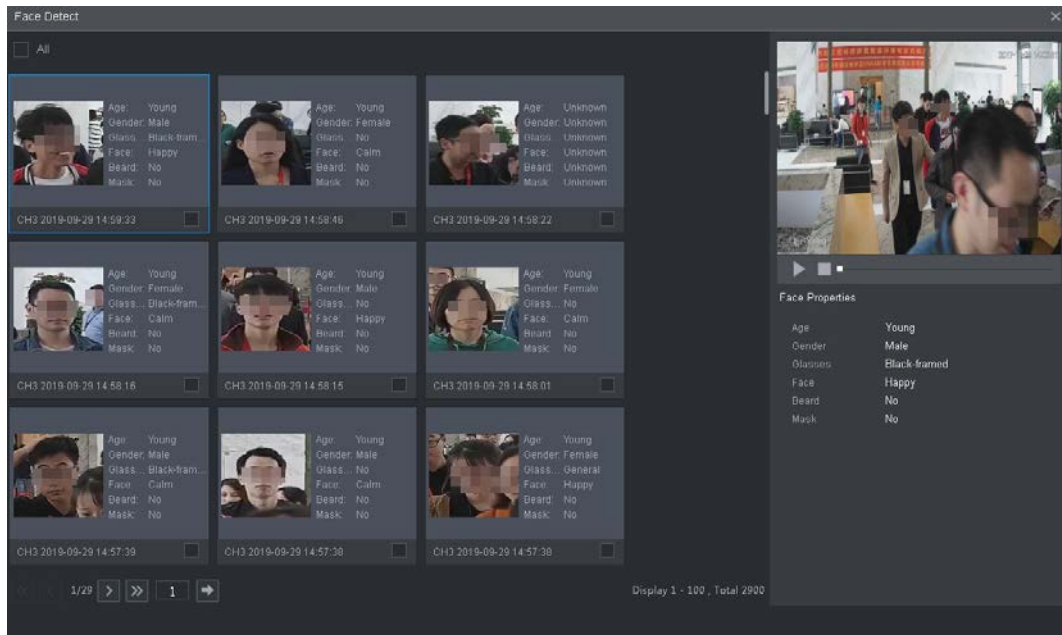

**Step 4** Select the face image you need to view, and click . The system starts playing back the video file that the image belongs to.



Double-click the playback interface to switch between full screen and small screen.

**Step 5** (Optional) Back up files.

- 1) Select files and click **Backup**.  
The **Export** interface is displayed. See Figure 5-10.
- 2) Select the backup address, path, backup type and file type, and click **Export**.  
File backup is completed.

Figure 5-10 Export (1)

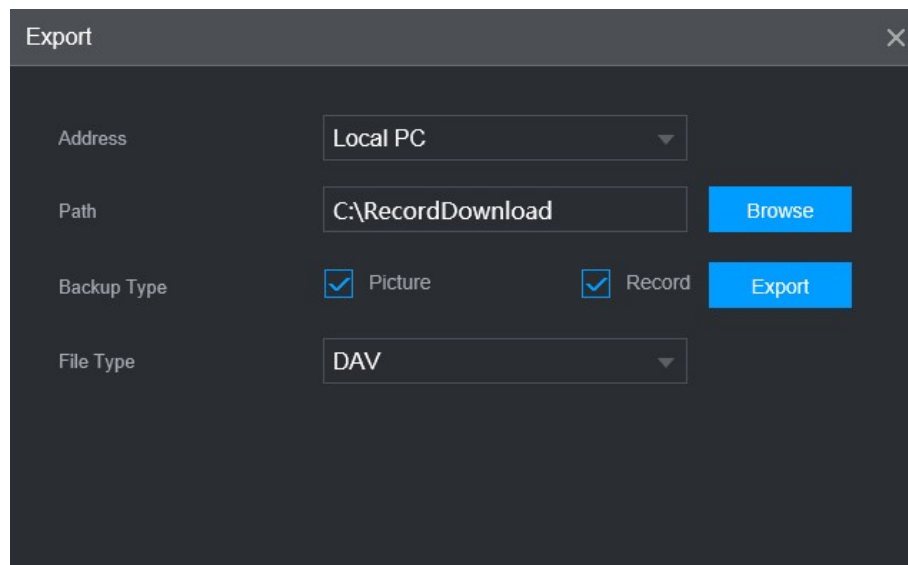

### 5.2.1.2 Face Matching

The face matching function can be used in two scenarios: AI Live and AI Search.

- In AI Live, the system can compare the detected faces with the faces in the configured face library, and display the results in AI Live interface.
- In AI Search, the system can search by face attributes or image comparison.



Before enabling the face matching function, enable the face detection function for the channel first.

### 5.2.1.2.1 Face Library Management

After successfully configuring the face library, the detected faces are compared with the information in the face library. Configuring a face library includes creating a face library, adding face images, and modeling faces.

You can create up to 20 face libraries and register up to 100,000 face images.



- To protect privacy, the faces in the images have been blurred intentionally.
- There is a DSM face library by default. It is configured from the platform, and cannot be modified and removed on the Recorder.

## Creating Face Library

**Step 1** On the main web interface, select **AI > Database > FACE LIBRARY**.

The **FACE LIBRARY** interface is displayed. See Figure 5-11.

Figure 5-11 Face library (1)

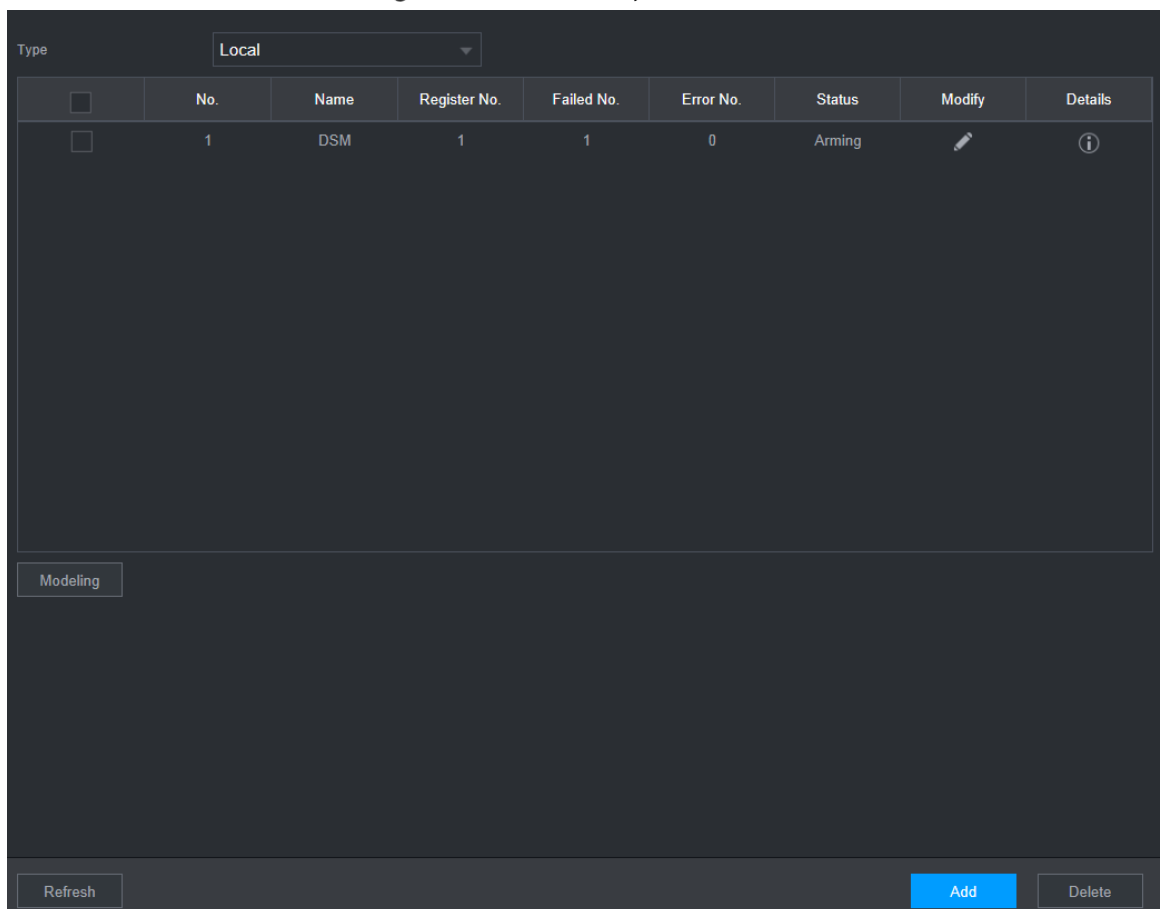

**Step 2** Click **Add**.

The **Add** interface is displayed. See Figure 5-12.

Figure 5-12 Add

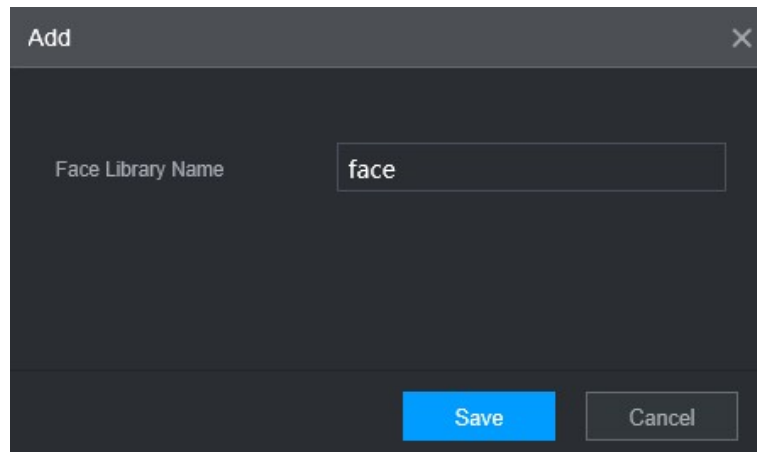

**Step 3** Enter Face Library Name and click **OK**.

The face library is saved successfully, and the **FACE LIBRARY (2)** interface is displayed. See Figure 5-13.



- Click the corresponding  in the face library list to modify the face library name.
- Click the corresponding  in the face library list to add face images to the face library.
- Select a face library and click **Modeling**. The system will extract the feature attributes of images in the face library for subsequent face matching.
- Select a face library and click **Del** to delete it.

Figure 5-13 Face library (2)



## Adding Face Images

You can add face images to the created face library, and single add and batch import are both supported.

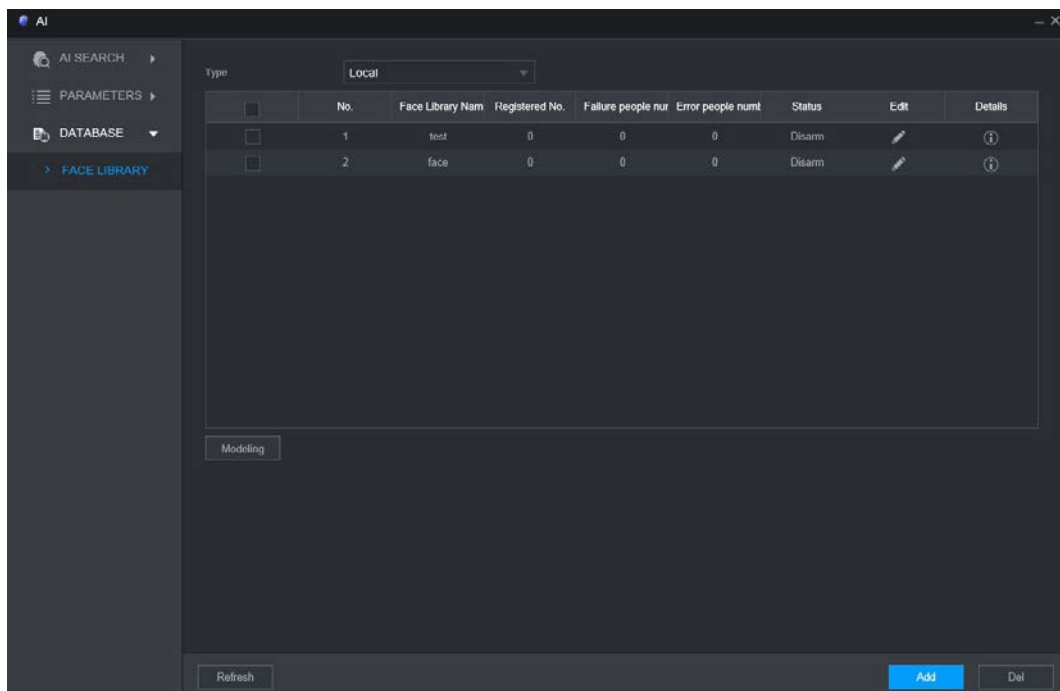

Both single add and batch import require to obtain face images from the USB flash drive. Images should be smaller than 256K with resolution from 200×200 through 6000×5000.

## Single Add

You can add face images one by one. When registering a small number of face images, use this method.

**Step 1** On the main web interface, select **AI > Database > FACE LIBRARY**.

The **FACE LIBRARY** interface is displayed. See Figure 5-13.

**Step 2** Click  corresponding to the face library to be configured.

The **Details** interface is displayed. See Figure 5-14.

Figure 5-14 Details (1)

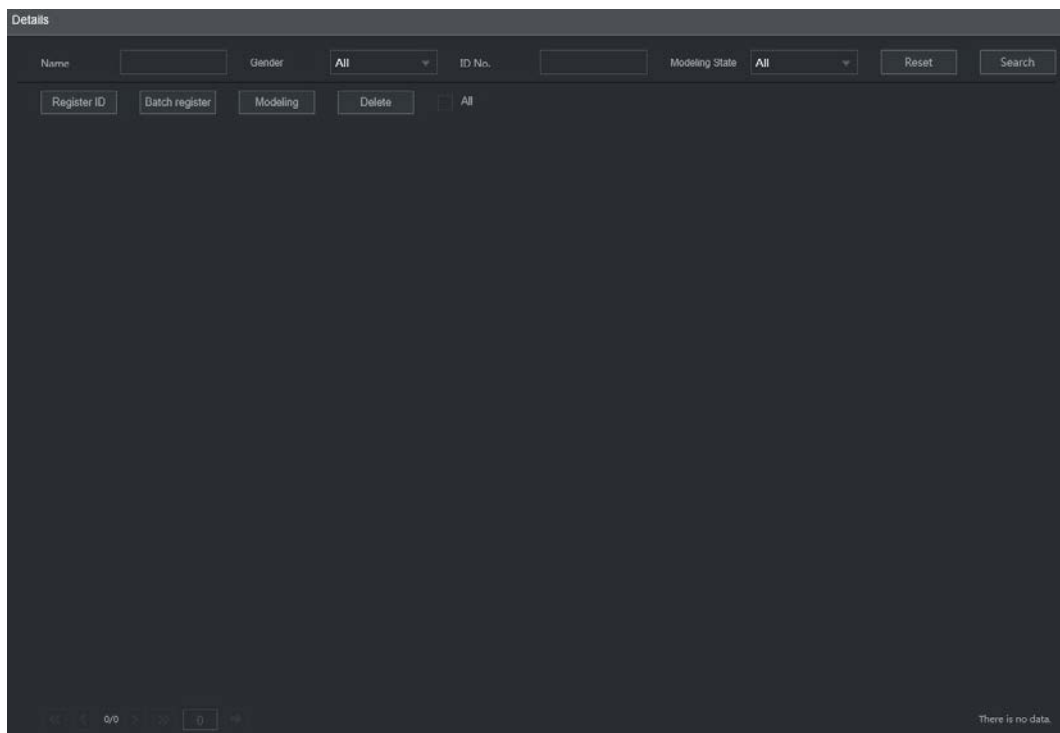

**Step 3** Click Register ID.

The **Register ID** interface is displayed. See Figure 5-15.

Figure 5-15 Register ID (1)

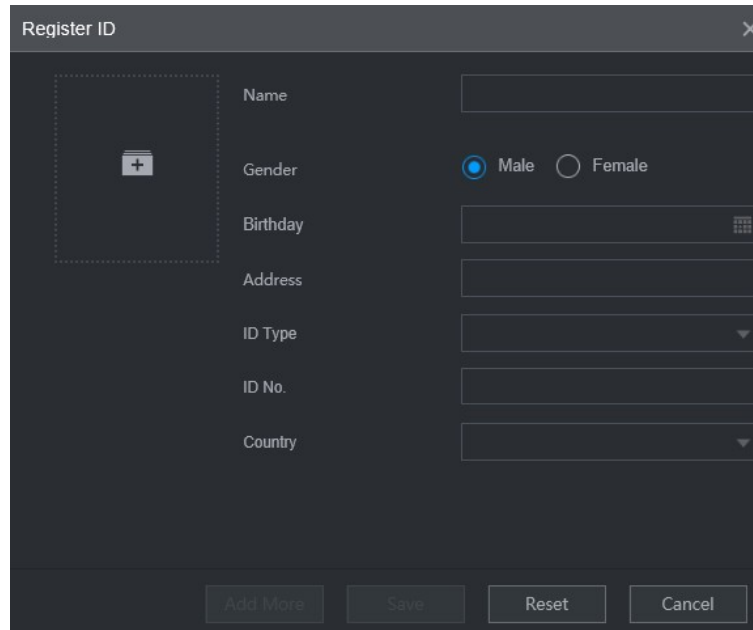

The screenshot shows a 'Register ID' window with a dark theme. On the left, there is a dashed box containing a plus sign icon. To the right of this box are several input fields: 'Name' (empty text box), 'Gender' (radio buttons for 'Male' and 'Female', with 'Male' selected), 'Birthday' (calendar icon), 'Address' (empty text box), 'ID Type' (dropdown menu), 'ID No.' (empty text box), and 'Country' (dropdown menu). At the bottom, there are four buttons: 'Add More', 'Save', 'Reset', and 'Cancel'.

**Step 4** Click  to add face photos.

Select a picture and fill in registration information. For system display, see Figure 5-16.

Figure 5-16 Register ID (2)

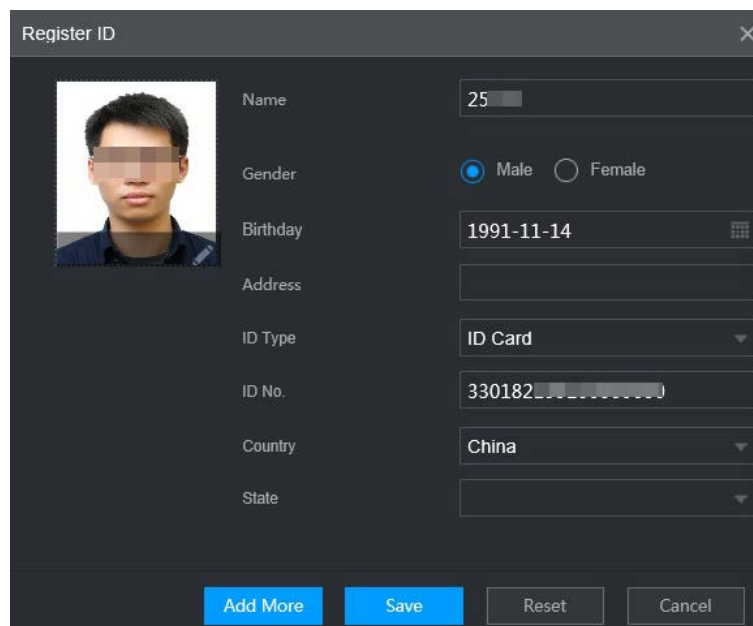

The screenshot shows the 'Register ID' window with a face photo of a man. The registration information is filled in: 'Name' is '25', 'Gender' is 'Male', 'Birthday' is '1991-11-14', 'Address' is empty, 'ID Type' is 'ID Card', 'ID No.' is '330182...', 'Country' is 'China', and 'State' is empty. The 'Add More' and 'Save' buttons are highlighted in blue. The 'Reset' and 'Cancel' buttons are grey.

**Step 5** Click **OK**.

The system displays "Operation is done successfully" and returns to the **Details** interface. See Figure 5-17.



If face image shows "Modeling", it means that the system is extracting the feature attributes of the photo. Click **Search** to refresh the interface, and "Modeling succeeded" is displayed. If modeling fails, the photo cannot be used for face matching.

Figure 5-17 Details (2)

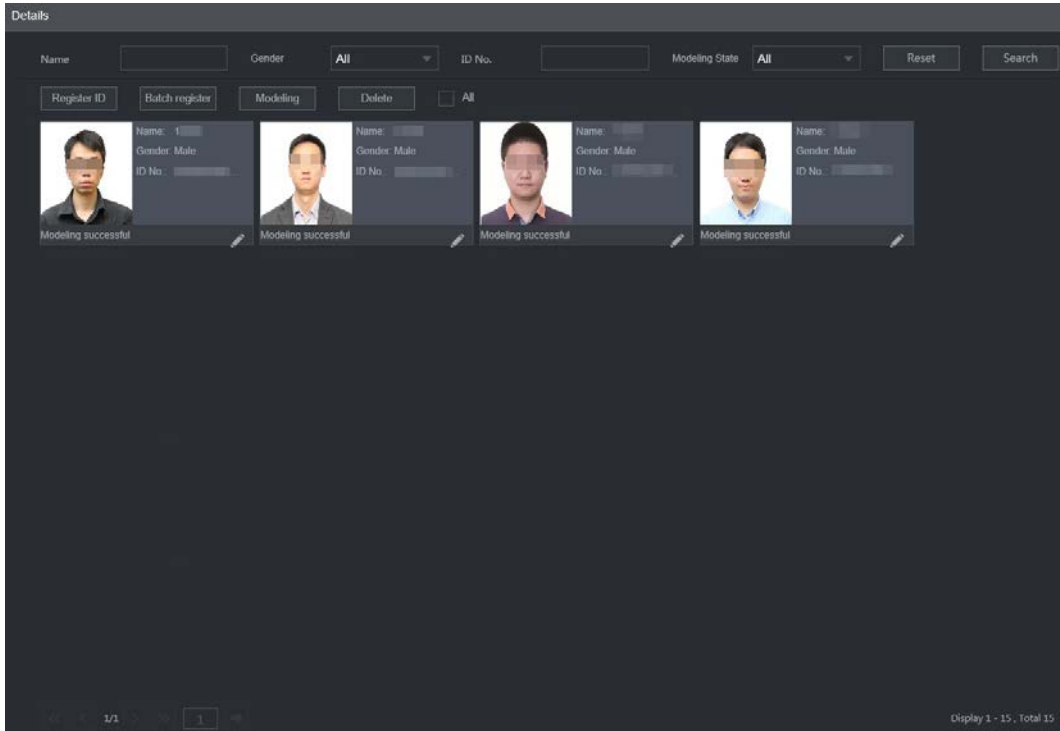

### Batch Add

If there are many face images to be registered, you can use the batch add function to import face images in batch.

**Step 1** Name the face images in the format of "Name#S Gender#B Birthday#N Country#P Province#T IDType#MID No.#A Address.jpg." For details, see Table 5-5.



Name is required and the rest are optional.

Table 5-5 Naming rules for batch import

Item	Description
Name	Enter the corresponding name.
Gender	Enter number 1 for male and 2 for female.
Birthday	Fill in the number in the format of yyyy-mm-dd, for example, 2017-11-23.
Country	Enter the corresponding country abbreviation.
Province	Fill in the English name of the province.
ID Type	Fill in the numbers, "1" for ID card, "2" for passport, and "3" for official card.
ID No.	Fill in the ID number.
Address	Enter the corresponding residence address.

**Step 2** On the face library details interface, click **Batch register**.

The **Batch register** interface is displayed. See Figure 5-18.

Figure 5-18 Batch register

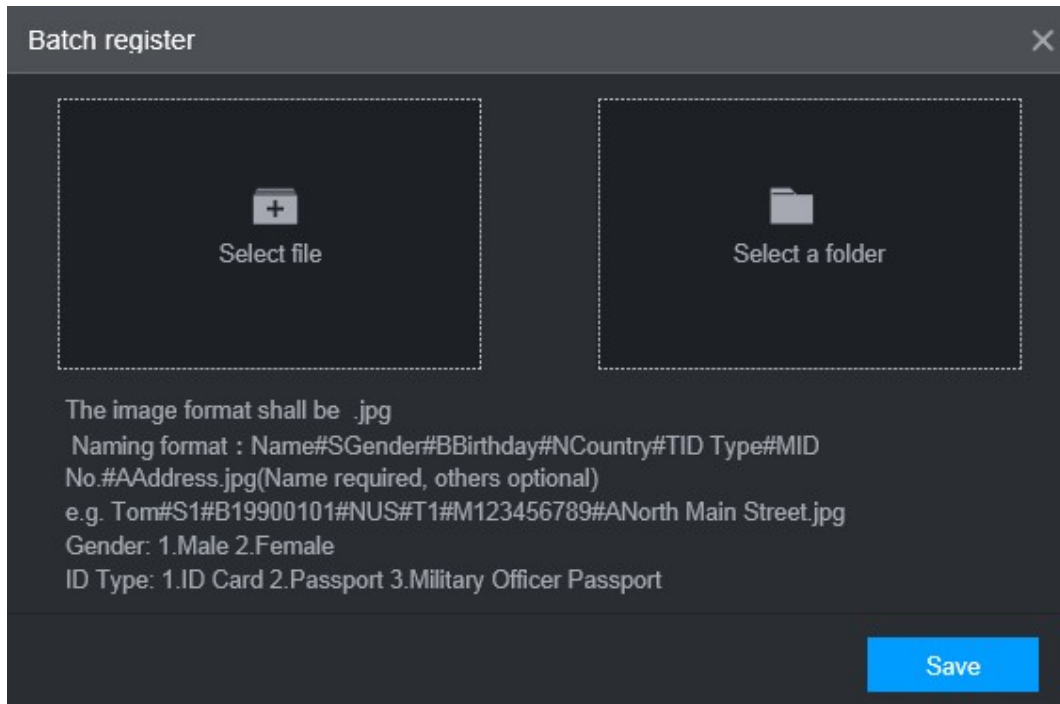

**Step 3** Click **Select file** (up to 500 images at a time) or **Select a folder** to select a file path to import the images.

**Step 4** Click **OK**.

### 5.2.1.2.2 Configuring Face Matching Settings

The system compares the detected faces with the faces in the face library to see whether the detected faces are in the face library. The comparison results are directly displayed in the AI Live interface and AI Search interface, and the system triggers alarm linkage.

#### Procedure

**Step 1** On the main web interface, select **AI > Parameters > Face Matching**. The **Face Matching** interface is displayed. See [错误!未找到引用源。](#)

Figure 5-19 Face Matching (1)

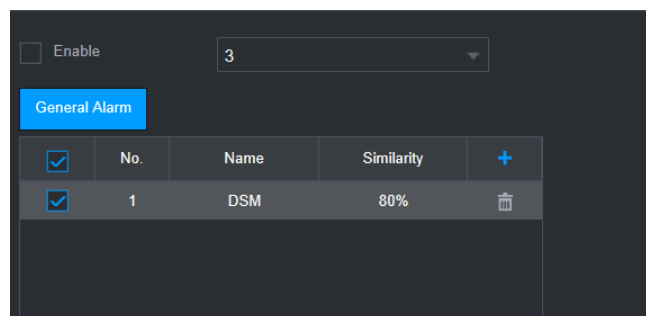

**Step 2** Select the channel number. Select **Enable** to enable the face matching function.

**Step 3** Select the type.



Only AI by Device is supported.

**Step 4** Set face library.

- 1) Click .

The **Face Library** interface is displayed. See Figure 5-20.

Figure 5-20 Face library

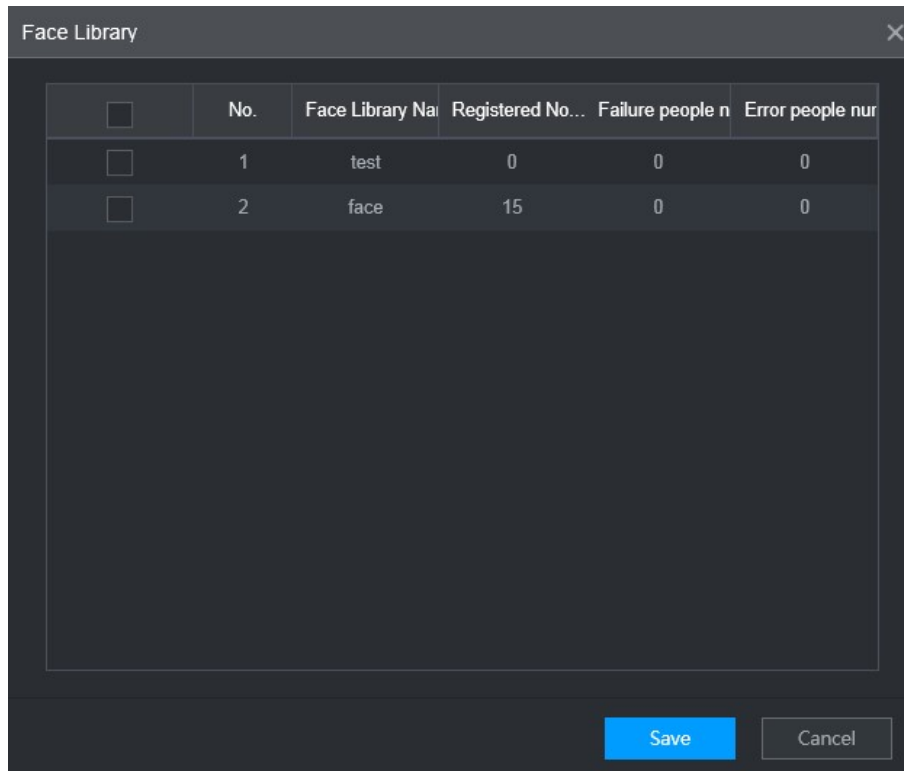

- 2) Select one or more face libraries to be added.
- 3) Click **OK**.

The face library information is displayed.

**Step 5** (Optional) Double-click the number under **Similarity** to modify the face matching similarity.



- The lower the similarity, the higher the probability of triggering face matching.
- Click  to delete the added face library.

**Step 6** Click **OK**.

### 5.2.1.2.3 AI Search

The system can search and compare the faces in the videos and the faces in the face library and play back the recordings.

**Step 1** On the main web interface, select **AI > AI Search > Face Matching**.

The **Face Matching** interface is displayed. See [错误!未找到引用源。](#)



Figure 5-21 Face matching (3)

Channel: 3  
Start Time: 2020-07-23 00:00:00  
End Time: 2020-07-23 23:59:59  
Gender: All  
Age: All  
Glasses: All  
Beard: All  
Mouth Mask: All  
Expression: All  
Similarity: 80%  
Search

**Step 2** Select the channel, start time and end time, and select face matching details (such as gender, age, glasses, beard, face mask, expression and similarity) as needed.

**Step 3** Click **Search**.

The search results are displayed. See Figure 5-22.

Figure 5-22 Attribute search result (2)

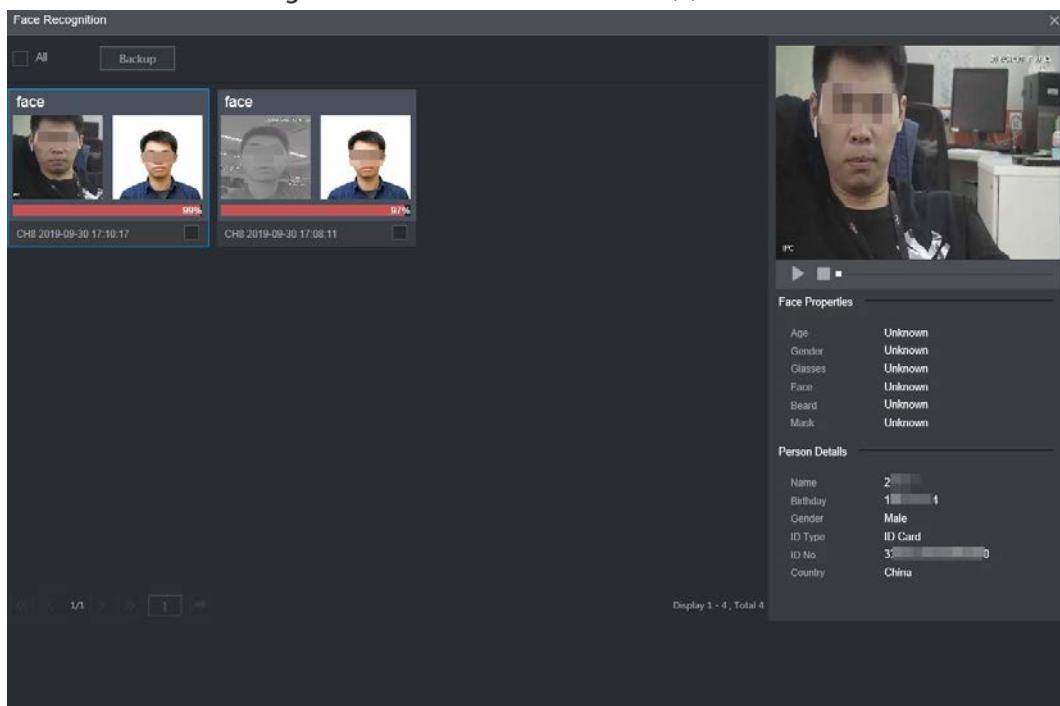

**Step 4** Select the face image you need to view, and click . The system starts playing back the video file that the image belongs to.



Double-click the playback interface to switch between full screen and small screen.

**Step 5** (Optional) Back up files.

1) Select files and click **Backup**.

The **Export** interface is displayed. See Figure 5-23.

- 2) Select the backup address, path, backup type and file type, and click **Export**.  
File backup is completed.

Figure 5-23 Export (2)

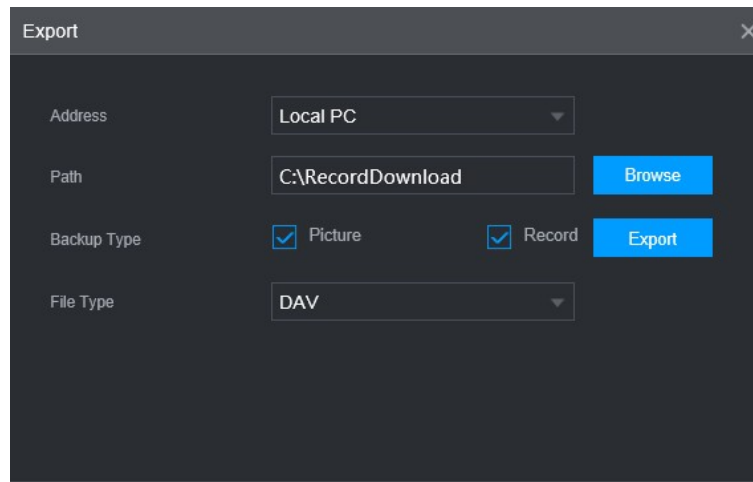

## 5.2.2 Active and Safe Drive

### 5.2.2.1 Configuring ADAS Function

#### Introduction

ADAS (Advanced Driving Assistance System) alarms mainly include forward collision warning, lane departure warning and headway monitoring warning. The Recorder can monitor the road conditions in front of the vehicle and generate an alarm through the front-view monitoring camera. After being triggered, these alarms require voice broadcast by means of TTS and need to be uploaded to the platform. After these alarms are triggered, the system will generate voice broadcast and report to the platform.

#### Preparation

- Access to cornering lamp signal in advance: Alarm Input\_2 (turn left), Alarm Input\_3 (turn right). After the cornering lamp of the vehicle is turned on, no Lane Departure alarm will be triggered.
- Config: Driver assistance relies on the camera installation location, and cannot be used until the calibration is completed. Try to install the camera in the middle of the windshield. When configuring parameters, measure the width of the vehicle, the height of the camera, and the distance from the camera to the vehicle head in advance. After the vehicle travels for a certain period of time, the device will automatically calibrate the position.

#### Matching Product

The front view monitoring camera is a camera used to monitor the conditions in front of the vehicle.

Figure 5-24 Front view monitoring camera



## Calibration

- Step 1** On the main web interface, select **AI > Parameters > ADAS**.  
The **ADAS** interface is displayed. See Figure 5-25.

Figure 5-25 ADAS

Channel	1	
Enable	<input type="checkbox"/>	
Forward Collision Warning	<input checked="" type="checkbox"/>	
Alarm Trigger Speed	30	Km/h(30-200)
Report Alarm	30	Km/h(30-200)
Alarm Protection Time	60	(s)(10-6525)
TTC	27	0.1(s)(20-100)
Lane Departure Warning	<input checked="" type="checkbox"/>	
Alarm Trigger Speed	30	Km/h(30-200)
Report Alarm	30	Km/h(30-200)
Alarm Protection Time	60	(s)(10-6525)
Distance of Driving on Solid...	0	cm(-30-30)
Headway Monitoring Warning	<input checked="" type="checkbox"/>	
Alarm Trigger Speed	30	Km/h(30-200)
Report Alarm	30	Km/h(30-200)
Alarm Protection Time	60	(s)(10-6525)
TTC	15	0.1(s)(10-100)

Tip : Make sure device has connected the cornering lamp.

Default Calibrate

- Step 2** Click **Enable** and **OK** to enable the ADAS alarm.

- Step 3** Click Calibrate.

The **Calibrate** interface is displayed.

Figure 5-26 Calibrate

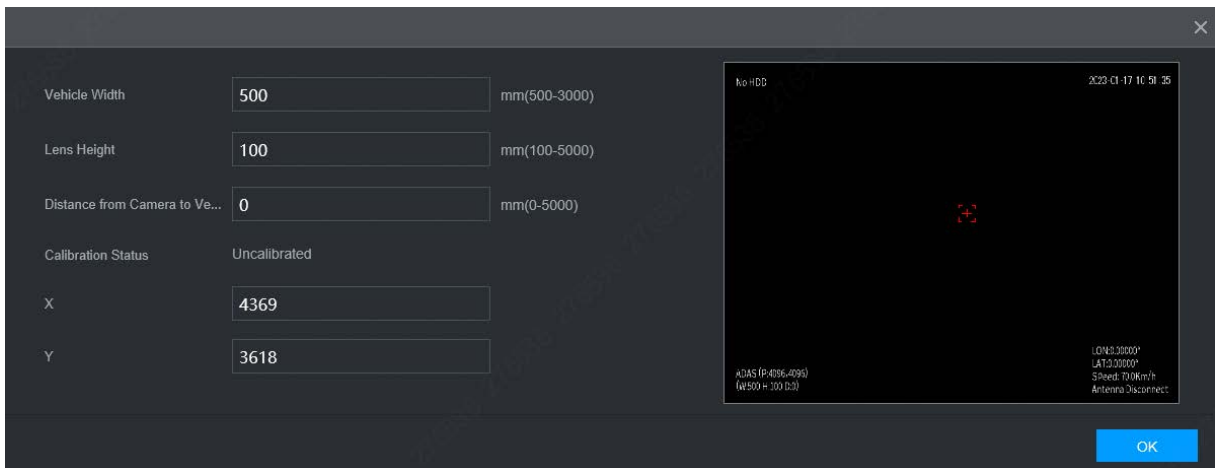

**Step 4** Enter the vehicle width, the lens height and the distance from the camera to the vehicle head, and click **OK** to complete the calibration. For details, see Table 5-6

Table 5-6 Calibration parameters

Parameter	Description
Vehicle width	The distance between the outside of two front wheels of the vehicle.
Lens height	Height of lens from the ground.
Distance from Camera to Vehicle Head	Distance between lens and vehicle head
X, Y	The X value represents the installation yaw angle of the camera, and the range is 2958-5233; The Y value represents the installation pitch angle of the camera, and the range is 3872-4320.

Figure 5-27 Distance measurement

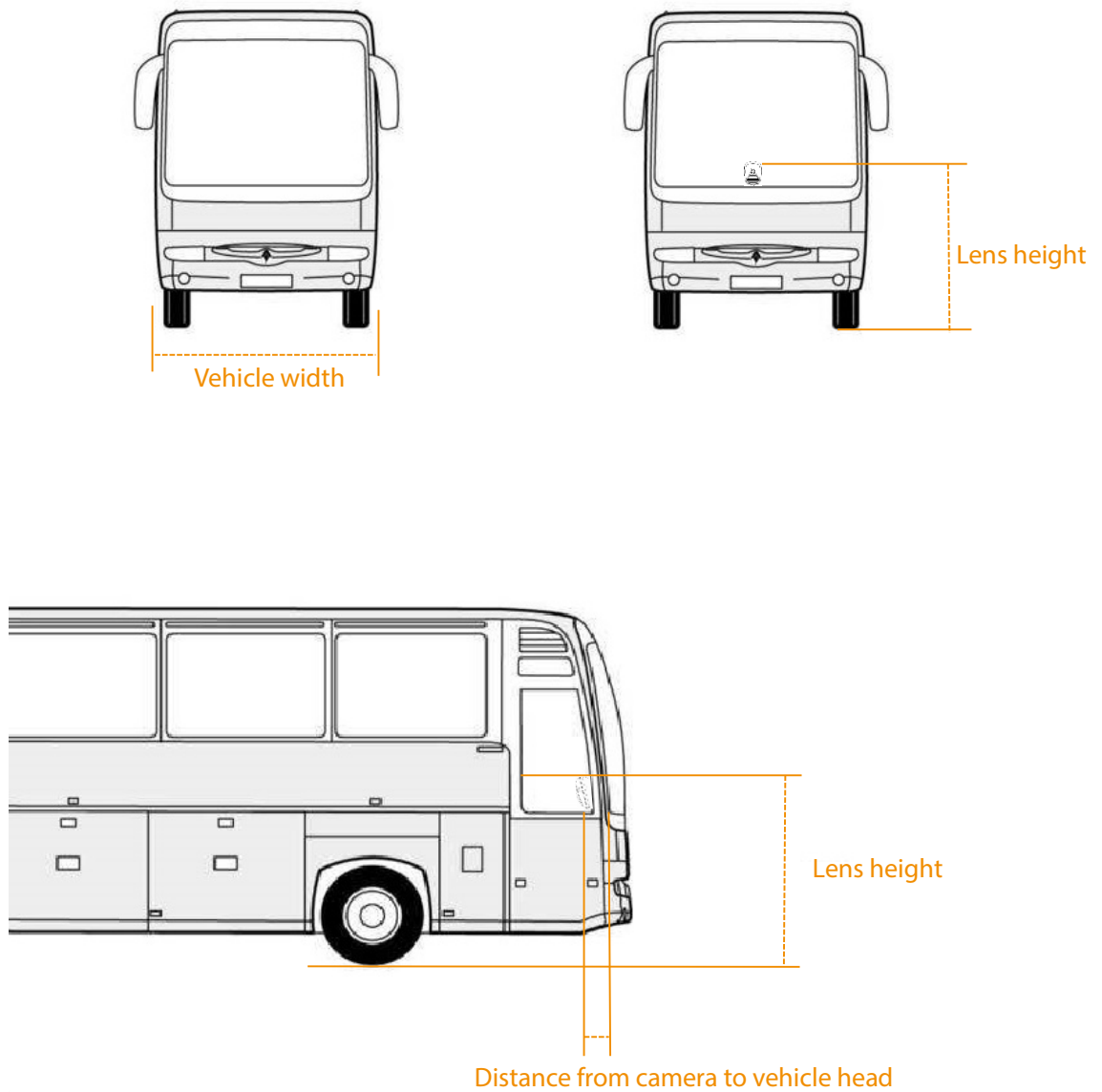

Step 5 Click **OK**.

## Configuring ADAS Parameters

Step 1 On the main WEB interface, select **AI > Parameters > ADAS**.

The **ADAS** interface is displayed.

Figure 5-28 ADAS

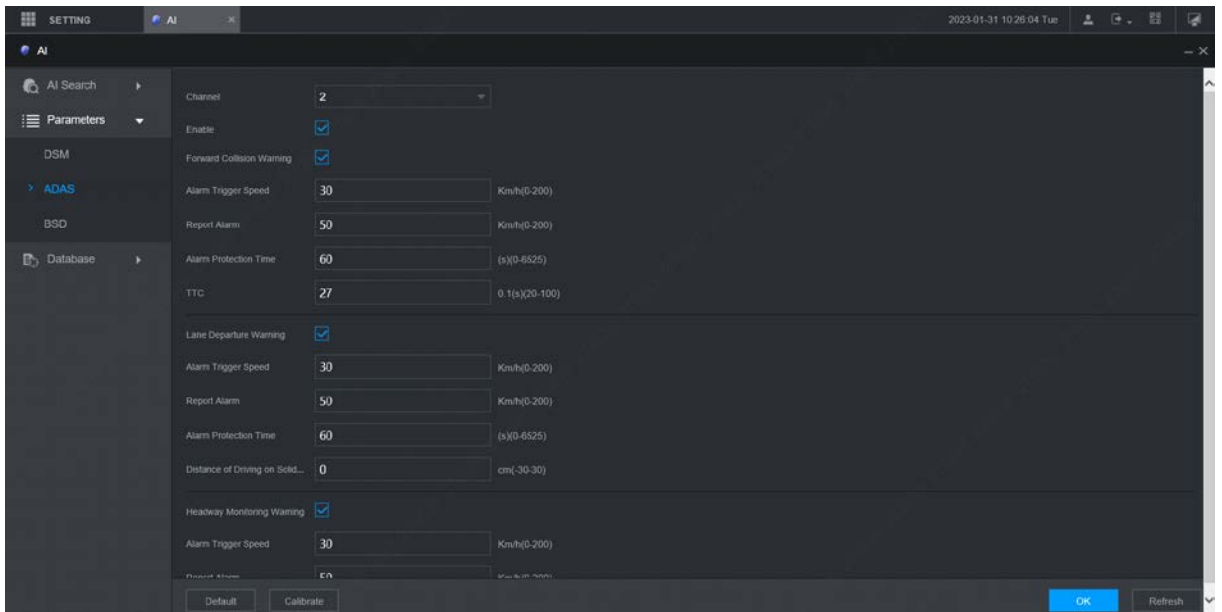

**Step 2** Select **Enable** and click **OK**.

**Step 3** Configure parameters. For details, see Table 5-7.



means the corresponding alarm is enabled.

Table 5-7 ADAS parameter description

Parameter	Description
Channel	ADAS is fixed to channel 2.
Forward collision warning	Gives out warning if it is possible to collide with the vehicle in front.
Alarm trigger speed	The speed at which the Forward Collision Warning is triggered: The range is 30km/h–200km/h.
Report alarm	The speed at which the Forward Collision Warning is uploaded to the platform: The range is 0km/h–200km/h.
Alarm protection time	Continuous alarm time: The range is 0s–6525s.
TTC	Time to collision: The range is 2s–10s.
Lane departure warning	Gives out warning when the vehicle directly changes the lane without turning on the left or right cornering lamp.
Alarm trigger speed	The speed at which the Lane Departure Warning is triggered: The range is 0km/h–200km/h.
Alarm upload	The speed at which the Lane Departure Warning is uploaded: The range is 0km/h–200km/h.
Alarm protection time	Continuous alarm time: The range is 0s–65536s.

Distance of driving on solid line	Set the distance of driving on solid line: The range is -30cm–30cm.
Headway Monitoring Warning	Gives out warning when the vehicle is too close to the vehicle in the front.
Alarm trigger speed	The speed at which the Headway Monitoring Warning is triggered: The range is 0km/h–200km/h.
Report alarm	The speed at which the Headway Monitoring Warning is uploaded: The range is 0km/h–200km/h.
Alarm protection time	Continuous alarm time: The range is 0s–6525s.
TTC	Time to collision: The range is 0s–10s.

Step 4 Click **OK**.

## 5.2.2.2 Configuring DSM Function

### Introduction

DSM (Driver Status Monitor) alarms mainly include drowsy driving, distracted driving, calling when driving, driver not in position, wearing infrared-blocking sunglasses, smoking when driving, and camera being shielded. The recorder can monitor and alarm unsafe driving behaviors through the driver monitoring camera. After being triggered, these alarms require voice broadcast by means of TTS and need to be uploaded to the platform.

### Matching Product

The driver monitoring camera is used to analyze the abnormal driving status of the driver. It can identify the unsafe driving behaviors of the driver during the driving process, such as drowsy driving, calling, distracted driving, smoking, etc., and generate an alarm by detecting the changes in the driver's eyes, face or behavior.

Figure 5-29 Driver Monitoring Camera



### Configuring DSM Parameters

Step 1 On the main web interface, select **AI > Parameters > DSM**.  
The **DSM** interface is displayed. See Figure 5-30.

Figure 5-30 DSM

Parameter	Value	Unit/Range
Channel	2	
Enable	<input type="checkbox"/>	
Working Mode	Normal	
Rule Type	Drowsy Driving	
Drowsy Driving	<input checked="" type="checkbox"/>	
Alarm Trigger Speed	30	Km/h(30-200)
Report Alarm	30	Km/h(30-200)
Alarm Protection Time	60	(s)(10-6525)
Closed Eyes Duration	2	(s)(1-10)
Yawn Duration	2	(s)(1-10)

**Step 2** Click **Enable** to enable the DSM alarm.

**Step 3** Configure parameters. For details, see Table 5-8.

Table 5-8 DSM parameter description

Parameter	Description
Channel	The DSM is fixed to channel 1.
Working mode	Vehicle working modes include normal mode and test mode.
Rule type	For alarm rules, you can select drowsy driving, distracted driving, calling when driving, driver not in position, wearing infrared-blocking sunglasses, smoking when driving, lens tempering, unbelted alarm, ID exception and substitution driving (not the correct driver).  <input checked="" type="checkbox"/> means the corresponding alarm is enabled.
Alarm trigger speed	The speed at which the alarm is triggered: The range is 0 km/h–200 km/h.
Report alarm	The speed at which the alarm is uploaded to the platform: The range is 0 km/h–200 km/h.
Alarm protection time	Continuous alarm time: The range is 100s–6525s.
Closed eyes duration	Setting is necessary when the rule type is <b>Drowsy Driving</b> : The range is 1s–10s.
Yawn duration	
Duration of lowering head	Setting is necessary when the rule type is <b>Distracted Driving</b> : The range is 1s–10s.
Duration of looking around	



Duration of calling	Setting is necessary when the rule type is <b>Calling When Driving</b> : The range is 1s–10s.
Duration of driver not in position	Setting is necessary when the rule type is <b>Driver not in Position</b> : The range is 2s–10s.
Duration of wearing infrared-blocking sunglasses	Setting is necessary when the rule type is <b>Wearing Infrared-Blocking Sunglasses</b> : The range is 1s–10s.
Duration of smoking	Setting is necessary when the rule type is <b>Smoking When Driving</b> : The range is 1s–10s.
Duration of acceleration when camera is shielded	Setting is necessary when the rule type is <b>Camera Being Masked</b> : The range is 1s–10s.

Step 4 Click **OK**.

## 5.2.3 Number Plate

Cameras connected to the Recorder can take snapshots of car plates. On the Recorder configure the area where number plate recognition works. Also, you can search for the car plate and play the corresponding video recording.

### 5.2.3.1 Number Plate Detection

Configure number plate detection region and its alarm settings.

#### Procedure

- Step 1 On the main interface, select **AI > Parameters > Plate No.**.  
The **Plate No** interface is displayed.

Figure 5-31 Plate No.

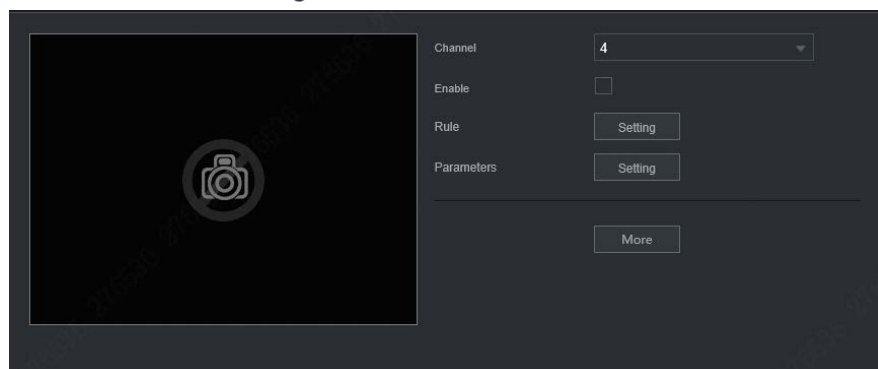

- Step 2 Select the channel in which you want to monitor the car plate and select **Enable** to enable the plate recognition function.
- Step 3 Configure parameters, see Table 5-9.

Table 5-9 Plate No. Parameters

Parameter	Description
Rule	<ol style="list-style-type: none"> <li>1. Click <b>Setting</b> next to <b>Rule</b>.</li> <li>2. Drag the yellow box four corners to adjust the recognition function size or shape.</li> </ol>
Parameters	<ol style="list-style-type: none"> <li>1. Click Setting next to Parameters.</li> <li>2. Configure more plate recognition settings. <ul style="list-style-type: none"> <li>◇ Sensitivity: The larger the value, the easier plates will be to be detected.</li> <li>◇ Interval: Within the interval, camera will not take snapshot of one plate twice.</li> <li>◇ Frame Rate: Video image frames per second.</li> <li>◇ Plate: When the plate state is blurry in the plate recognition region, use this state information automatically.</li> </ul> </li> </ol>
Buzzer	Click <b>More Setting</b> and select <b>Buzzer</b> . Set buzzer alarm to give out reminding.
Log	Click <b>More Setting</b> and select <b>Log</b> to record plate recognition.

Step 4 Click **OK**.

### 5.2.3.2 Plate No. Recording Search

Search time (or search plate number plus time if you know the plate No.) for the corresponding video recording for you to play and check.

#### Procedure

Step 1 On the main interface, select **AI > AI Search > Plate No.**

The **Plate No.** interface is displayed. See Figure 5-32.

Figure 5-32 Searching plate

Step 2 Enter a channel, start time, end time. (And enter plate number if you know the plate number.)

Step 3 Click Smart Search.

Results are displayed. See Figure 5-33.

Figure 5-33 Smart search results

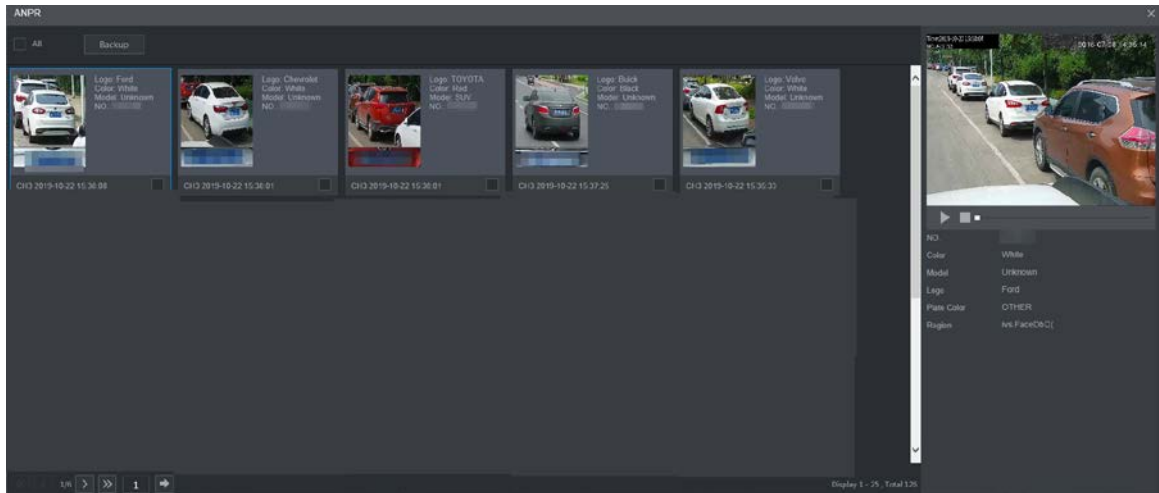

**Step 4** Select the plate item you want to view. Click  to play corresponding video recording. Double-click video recording image to switch playing between full screen and partial screen.

**Step 5** Export files.

1) Select files and click **Copy**.

The **Export** interface is displayed. See Figure 5-34.

Figure 5-34 Exporting files

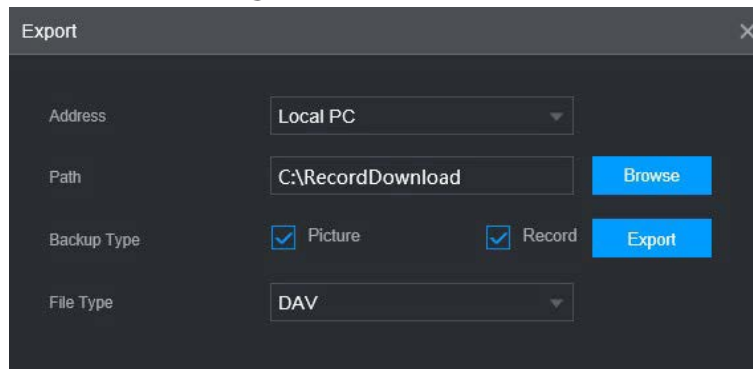

2) Select Address, Path, Backup Type and File Type. Then click Export.

## 5.2.4 Passenger Flow Measurement

The system can count the number of passengers in and out at each stop. The alarm in channels are connected to the doors for detecting door open and close. For example, if the alarm in Channel 3 is connected to the front door and bound to Camera 3 (overlooking the front door), when the door opens, Camera 3 will start counting the number of people, and when the door closes, the counting stops. The people counting data starts from 0 at each stop.

**Step 1** On the main interface, select AI > Parameters > Passenger Flow Measurement.

The **Passenger Flow Measurement** interface is displayed.

Figure 5-35 Passenger Flow Measurement

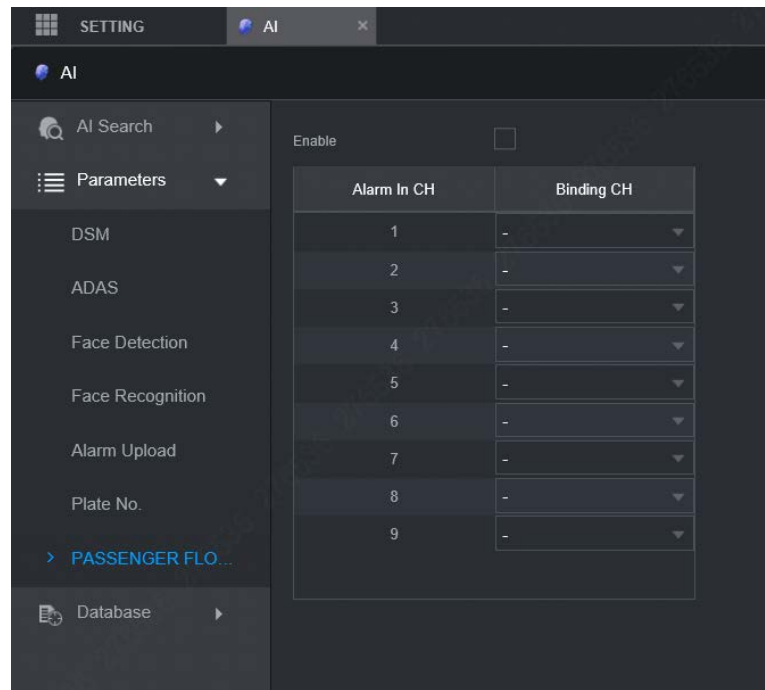

**Step 2** Select the **Enable** check box to enable the function.

**Step 3** Select the specific camera channel from the **Binding CH** column to bind to the corresponding alarm in channel in the **Alarm In CH** column.

**Step 4** Click **OK**.

## 5.3 Backing up File

You can back up video recordings and images.

**Step 1** On the main web interface, click **BACKUP**.

Figure 5-36 Backup (1)

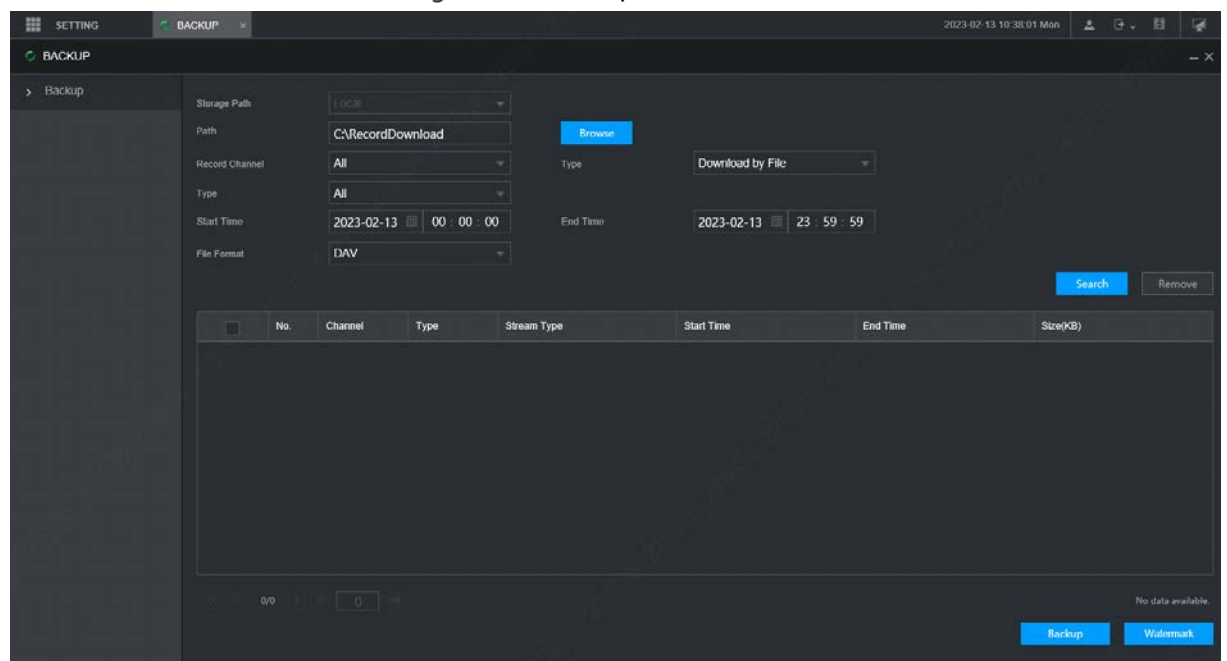

**Step 2** Configure parameters. For details, see Table 5-10.

Table 5-10 Backup parameters

Parameter	Description
Path	File backup path is C://RecordDownload by default. Click <b>Browse</b> to set the backup path as needed.
Record Channel	Select the channel you want to do the backup for.
Download Type	Select the backup type, including download by file and download by time.
Start time	Set the file backup period.
End time	
File Format	Select the backup file format, including DAV and MP4.
Record type	Select the record type, including external alarm, motion detect, all alarms, normal record, picture, and all.

**Step 3** Click **Search**.

The obtained files are displayed.

**Step 4** Select the file that you want to back up, and click **Backup**.

Figure 5-37 Backup (2)

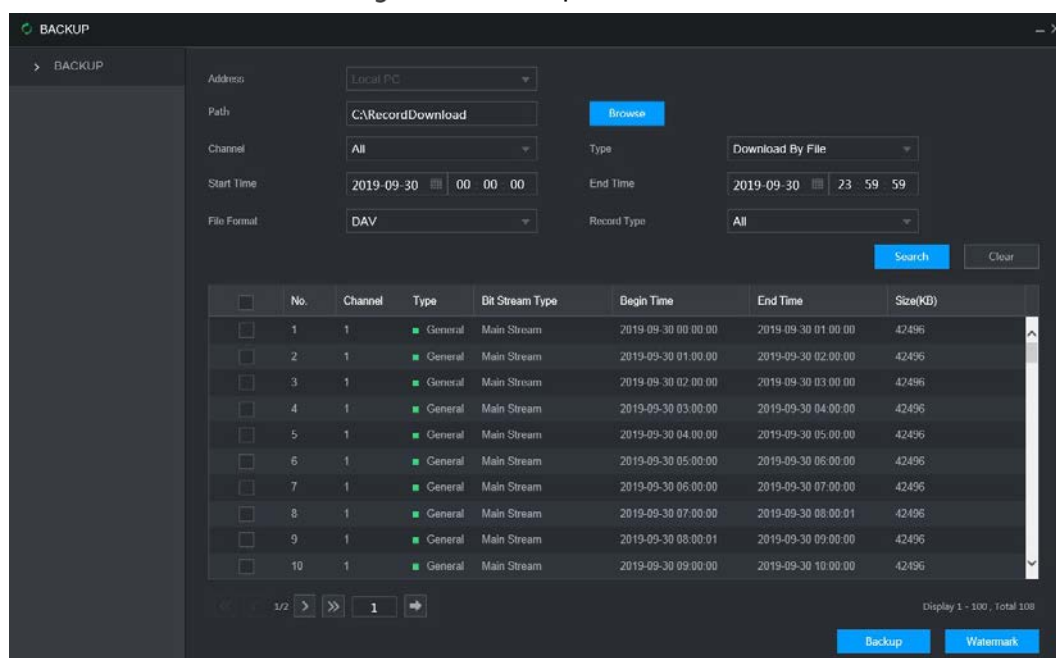

**Step 5** Click View Download.

The **Download** interface is displayed. See Figure 5-38.

Figure 5-38 Download

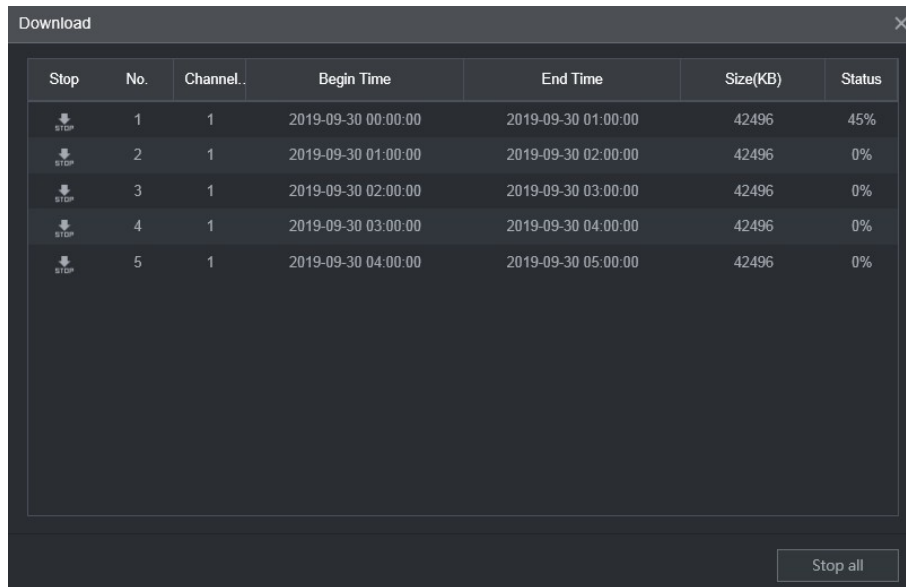

Stop	No.	Channel.	Begin Time	End Time	Size(KB)	Status
↓ STOP	1	1	2019-09-30 00:00:00	2019-09-30 01:00:00	42496	45%
↓ STOP	2	1	2019-09-30 01:00:00	2019-09-30 02:00:00	42496	0%
↓ STOP	3	1	2019-09-30 02:00:00	2019-09-30 03:00:00	42496	0%
↓ STOP	4	1	2019-09-30 03:00:00	2019-09-30 04:00:00	42496	0%
↓ STOP	5	1	2019-09-30 04:00:00	2019-09-30 05:00:00	42496	0%



Click **Stop all** to stop downloading.

**Step 6** (Optional) Select the file that you want to verify, and click **Watermark**.



**Watermark** can be used to verify whether the record file is falsified.  
The verifying progress and result are displayed.

## 5.4 Configuring Display Output Settings

You can configure device tour and video mirror settings.

### 5.4.1 Tour Settings

**Step 1** On the main web interface, select **DISPLAY > Tour Setting**.  
The **Tour Setting** interface is displayed.

Figure 5-39 Tour Setting

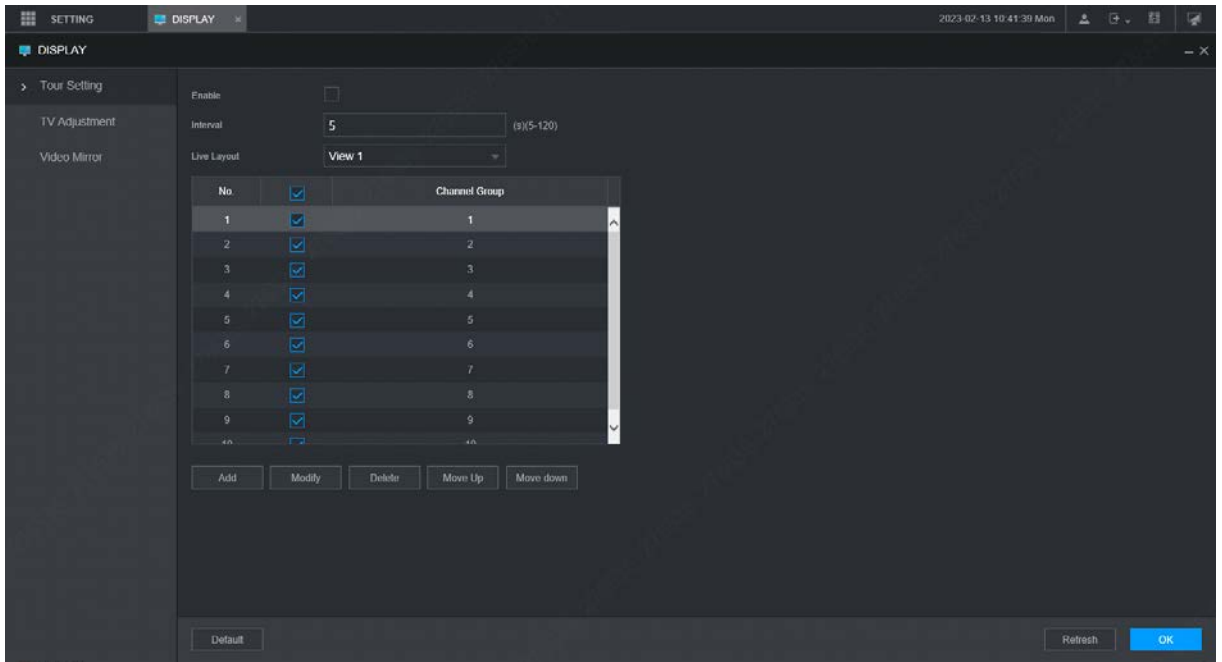

**Step 2** Click **Enable** to enable the tour settings.

**Step 3** Configure parameters. For details, see Table 5-11.

Table 5-11 Tour parameters

Parameter	Description
Interval	Set the tour interval.
Window split	The window split modes include single screen and 4-screen.

**Step 4** Click **Add**.

The **Add Group** interface is displayed.

Figure 5-40 Add group

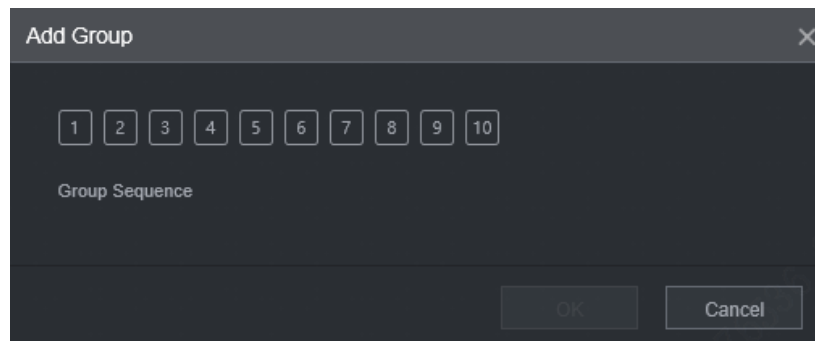

**Step 5** Select the channel and click **OK**.

Repeat Step 4–Step 5 to add multiple channel groups in tour.

**Step 6** Click **OK**.

- Select a channel group, and click **Modify** to modify the channel group and channel sequence.
- Select a channel group, and click **Delete** to delete it.
- Select a channel group, and click **Move up** or **Move down** to modify the channel group sequence.

## 5.4.2 TV Adjustment

**Step 1** On the main web interface, select **DISPLAY > TV Adjustment**.  
The **TV Adjustment** interface is displayed.

Figure 5-41 TV Adjustment

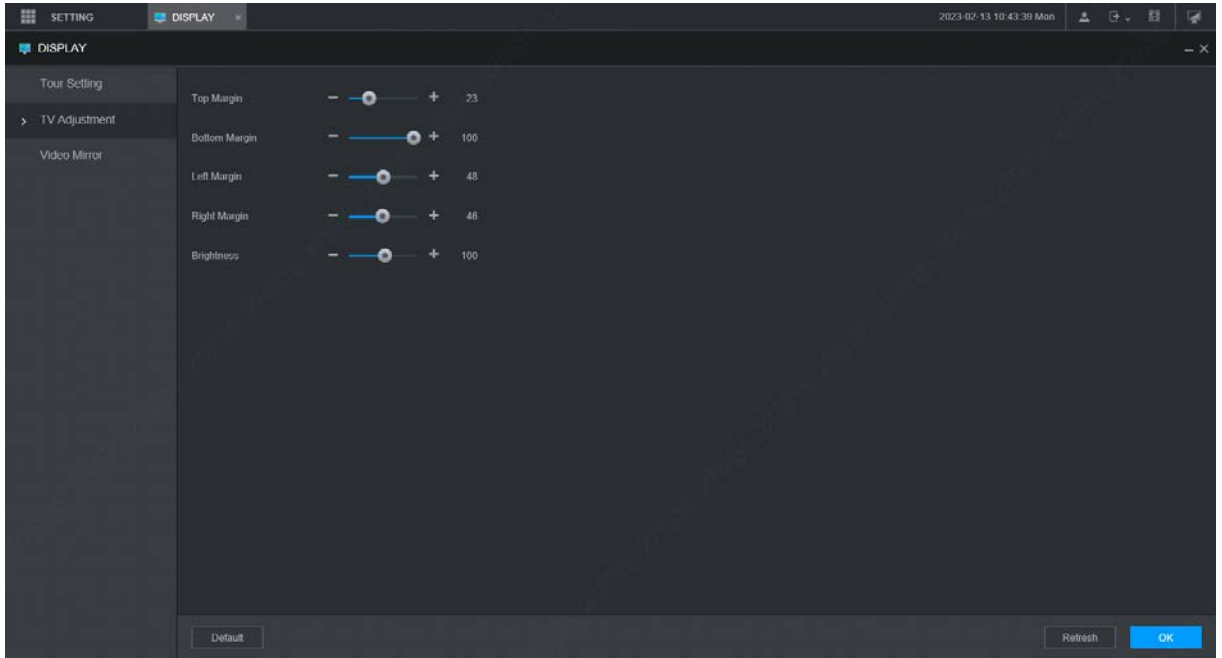

**Step 2** Drag the adjustment button to adjust the margins and brightness of the picture

## 5.4.3 Video Mirror Settings

**Step 1** On the main web interface, click **DISPLAY > Video Mirror**.  
The **Video Mirror** interface is displayed. See Figure 5-42.



Figure 5-42 Video mirror

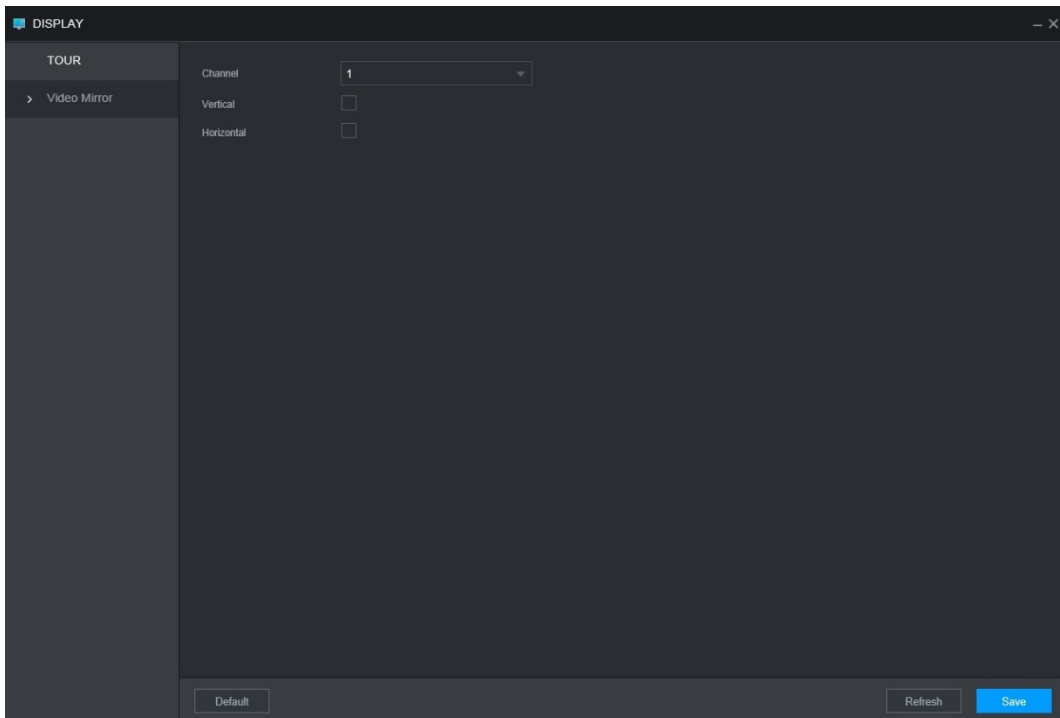

Step 2 Select a channel.

Step 3 Select a mirror mode. You can select **Vertical** or **Horizontal**.

Step 4 Click **OK**.

## 5.5 Configuring Camera Parameters

You can set camera properties, encoding parameters, PTZ properties, and view PoE power supply information.

### 5.5.1 Camera Properties

You can set up the camera property parameters of the channel.



Different cameras correspond to different property parameters. The actual parameters shall prevail.

Step 1 Select **SETTING > CAMERA > Image**.

The **Image** interface is displayed.

Figure 5-43 Image

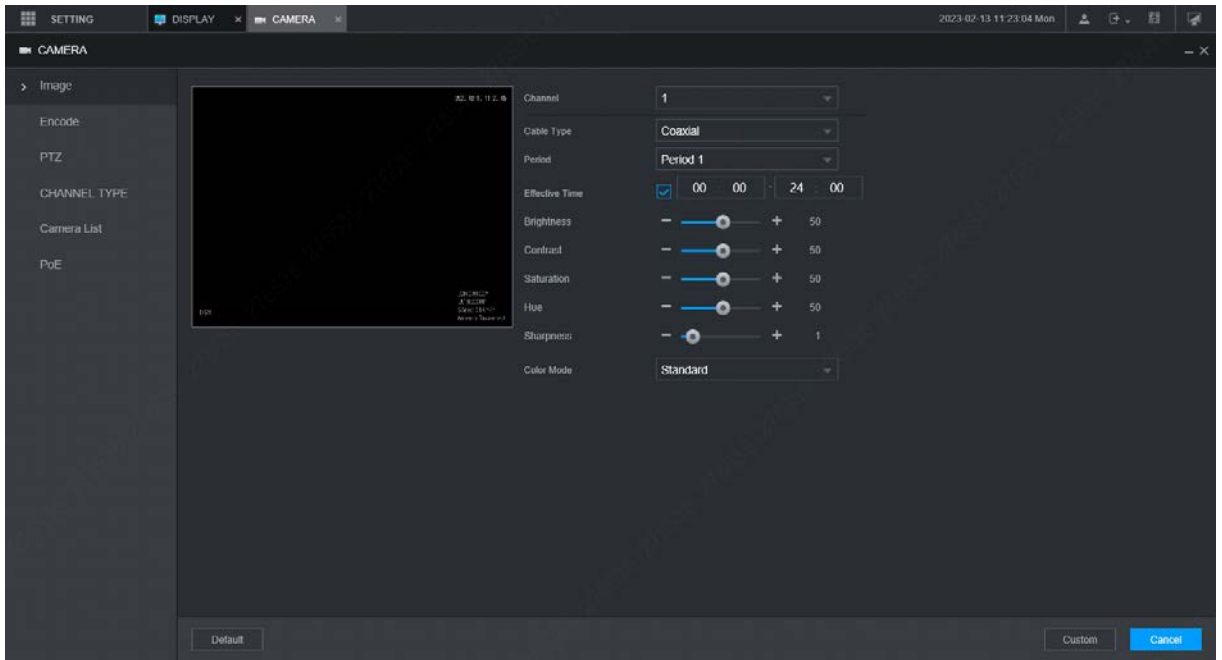

**Step 2** Select a channel.

**Step 3** Configure parameters.

Table 5-12 Image property parameters

Parameter	Description
Cable Type	The cable type is fixed to coaxial.
Period	Select the period. There are two Periods for you. You should set up the Effective Time for different periods.
Brightness	Adjusts the image brightness through linear mode. The bigger the value is, the + brighter the image will become.
Contrast	Adjust the image contrast. The bigger the value is, the more obvious the contrast between the light area and dark area will become.
Saturation	Adjusts the color darkness. Adjust the saturation according to the actual situation. The bigger the value, the lighter the color of the image will become.
Hue	Adjusts the color hue. Adjust the hue according to the actual situation. The bigger the value, the colder the color of the image will become.
Sharpness	Set the sharpness of picture edges. The bigger the value is, the more obvious the image edge will become.
Hue	Adjusts the color darkness. Adjust the saturation according to the actual situation. The bigger the value, the lighter the color of the image will become.
Color Mode	Select the color mode. There are 5 preinstall modes you can choose, or you can set 4 custom modes for options. Preinstall modes includes Standard, Soft, Bright, Vivid, Bank.

**Step 4** Click **OK**.

## 5.5.2 Encode Parameters

You can configure **Encode**, **Snapshot**, **Overlay**, and **Storage Path**.

## 5.5.2.1 Encode

You can configure the encode settings for main stream and sub stream.

**Step 1** Select SETTING > CAMERA > Encode > Audio/Video.

The **Audio/Video** interface is displayed.



Encode parameters might be different depending on devices, and the actual product shall prevail.

Figure 5-44 Audio/Video

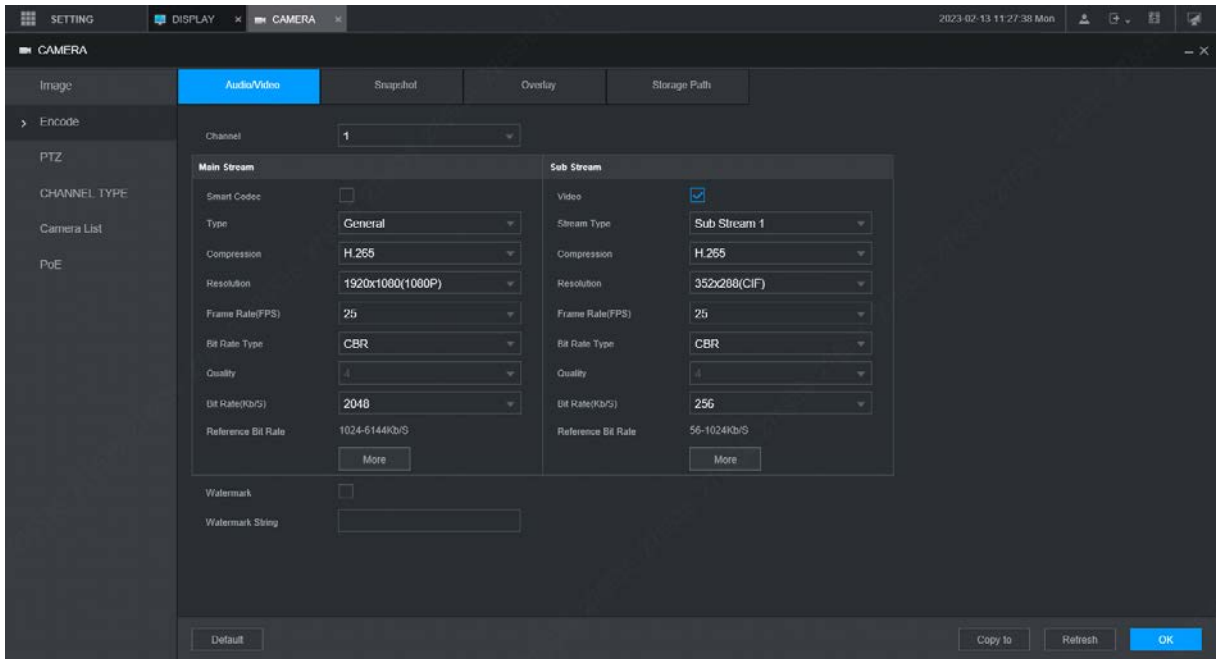



**Step 2** Select a channel.

**Step 3** Configure parameters.

Table 5-13 Encode parameters

Parameter	Description
Smart Codec	Enabling <b>Smart Codec</b> helps compress the images more and reduce the storage space.
Video enable	Enable the sub stream.
Record type	The record type of main stream is permanently fixed as <b>General</b> and cannot be changed. General, motion detect and alarm use the general stream configurations for recording.
Code-stream type	Sub stream types.
Compression	Compression mode.
Resolution	The higher the video resolution, the better the image quality.
Frame rate (FPS)	Configure the frames per seconds for videos. The higher the value, the smoother and more vivid the image.

Bit rate type	<p>You can select the bit rate type.</p> <ul style="list-style-type: none"> <li>● CBR: Constant Bit Rate, which changes around the configured value.</li> <li>● VBR: Variable Bit Rate, which changes along with environment.</li> </ul>  <ul style="list-style-type: none"> <li>● It is recommended to select CBR when there might be only small changes in the monitoring environment, and select VBR when there might be big changes in the monitoring environment.</li> <li>● The main stream is fixed to VBR.</li> </ul>
Quality	<p>This parameter can be set only when <b>Bit Rate Type</b> is set to <b>VBR</b>.</p> <p>The image quality level. There are six levels in total. The higher the value, the better the image will become.</p>
Bit rate (kb/s)	<p>Configure the bit rate for main stream and sub stream.</p> <ul style="list-style-type: none"> <li>● When CBR is selected, select the bit rate according to the reference bit rate, and the bit rate changes around the configured value.</li> <li>● When VBR is selected, select the upper limit value of bit rate according to the reference bit rate, and the bit rate changes along with the monitoring environment. But the maximum bit rate value changes around the configured value.</li> <li>● Select <b>Customized</b> to configure bit rate value manually.</li> </ul>
Reference bit rate	<p>The system recommends the optimal bit rate range according to the resolution and frame rate settings.</p>
Audio enable	<p>Click <b>More Setting</b> to enable the audio.</p> <p>If the corresponding check box is selected, the video recordings are audio and video combined streams.</p>
Audio encoding	<p>Select an audio encode format.</p>  <p>The parameters might be different depending on the model you purchased, and the actual product shall prevail.</p>
Audio source	<p>Source of audio.</p>
Watermark enable	<p>Select the <b>Watermark Enable</b> check box to verify whether the video recording is falsified.</p>
Watermark string	<p>Enter the strings for verifying watermark. The default string is DigitalCCTV. The watermark string can only consist of number, letter, underline (_), and hyphen (-), and the maximum length is 127 characters.</p>

Step 4 Click **OK**.

### 5.5.2.2 Snapshot

You can configure the snapshot settings such as mode, size, quality, and interval.

Step 1 Select SETTING > CAMERA > Encode > Snapshot.

The **Snapshot** interface is displayed.

Figure 5-45 Snapshot

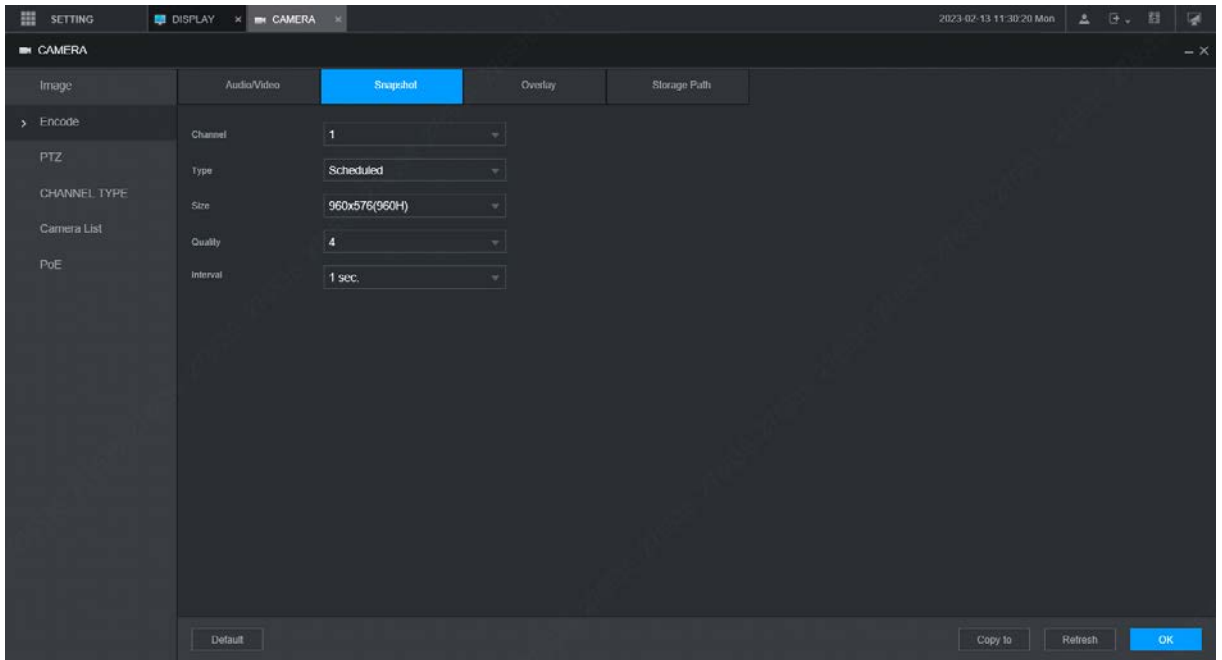

**Step 2** Select a channel.

**Step 3** Configure more parameters. See Table 5-14.

Table 5-14 Snapshot parameters

Parameter	Description
Mode	Includes timing and event. <ul style="list-style-type: none"> <li>Timing: Take snapshots within the configured period.</li> <li>Event: Take snapshots when alarms such as local alarm, video detection and abnormality are triggered.</li> </ul>
Size	Select a resolution for the captured images.
Quality	The image quality and there are six levels in total.
Interval	Interval of taking snapshots. Select <b>Customized</b> to configure the snapshot interval for manually captured snapshots. The maximum value you can set is 3600 seconds as an interval between two snapshots.

**Step 4** Click **OK**.

### 5.5.2.3 Overlay

You can configure the title of video image overlay.

**Step 1** Select SETTING > CAMERA > Encode > Overlay.

The **Overlay** interface is displayed.

Figure 5-46 Overlay

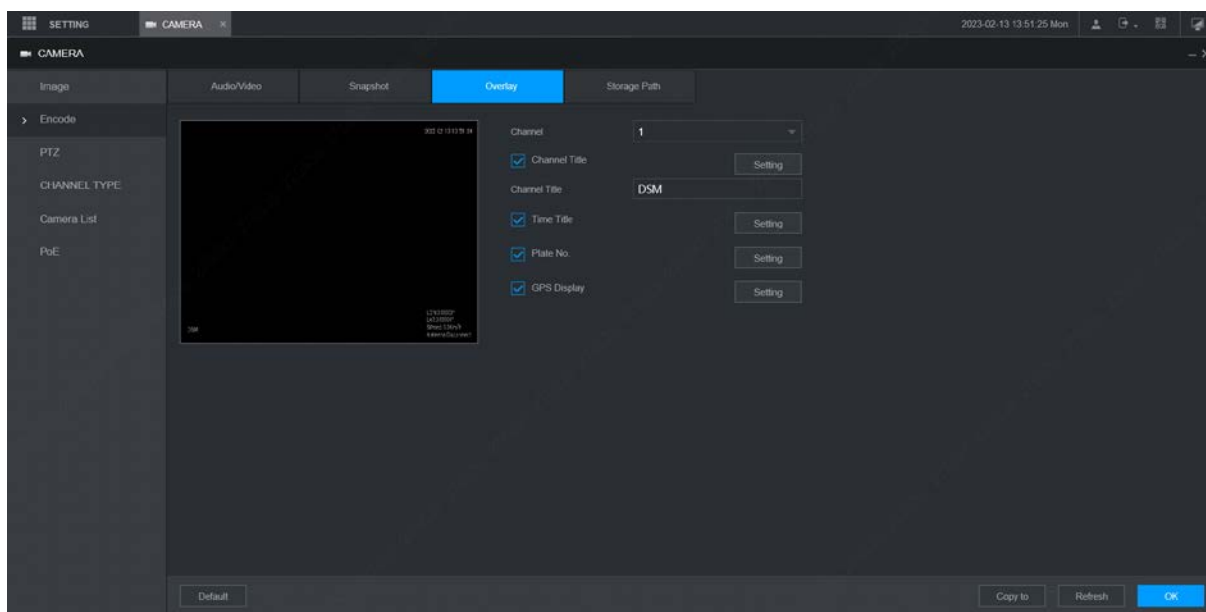

**Step 2** Select a channel.

**Step 3** See Table 5-15.

Table 5-15 Overlay parameters

Parameter	Description
Channel title	Select <b>Channel Title</b> , and the <b>Setting</b> button is displayed. Then click <b>Setting</b> on the right of the <b>Channel Title</b> , enter the channel title, and drag it to a proper location.
Time title	Select the <b>Time Title</b> check box, the <b>Setting</b> button is displayed. Then click <b>Setting</b> on the right of the <b>Time Title</b> , and then drag it to a proper location.
GPS display	Select the <b>GPS Display</b> check box, the <b>Setting</b> button is displayed. Then click <b>Setting</b> on the right of the <b>GPS Display</b> , and then drag it to a proper location.

**Step 4** Click **OK**.

## 5.5.2.4 Storage Path



You can configure the storage path of captured snapshots and video recordings.

**Step 1** Select **SETTING > CAMERA > Encode > Storage Path**.

The **Storage Path** interface is displayed.

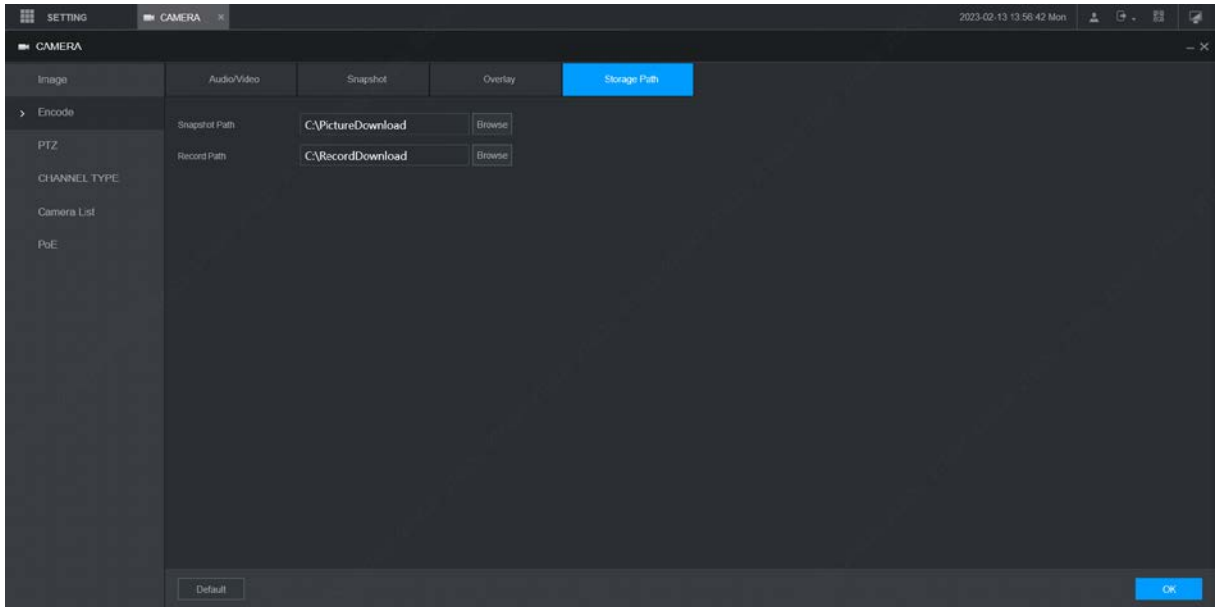
Figure 5-47 Path



**Step 2** Click **Browse** to select the save path for snapshots and recordings. Images and recordings by using functions of snapshots  and recordings  on the **Live** interface are saved in these two paths by default: C:\PictureDownload and C:\RecordDownload.

**Step 3** Click **OK**.

## 5.5.3 PTZ

You can configure the corresponding PTZ of the device channel.

**Step 1** Select SETTING > CAMERA > PTZ.

The **PTZ** interface is displayed. See Figure 5-48.



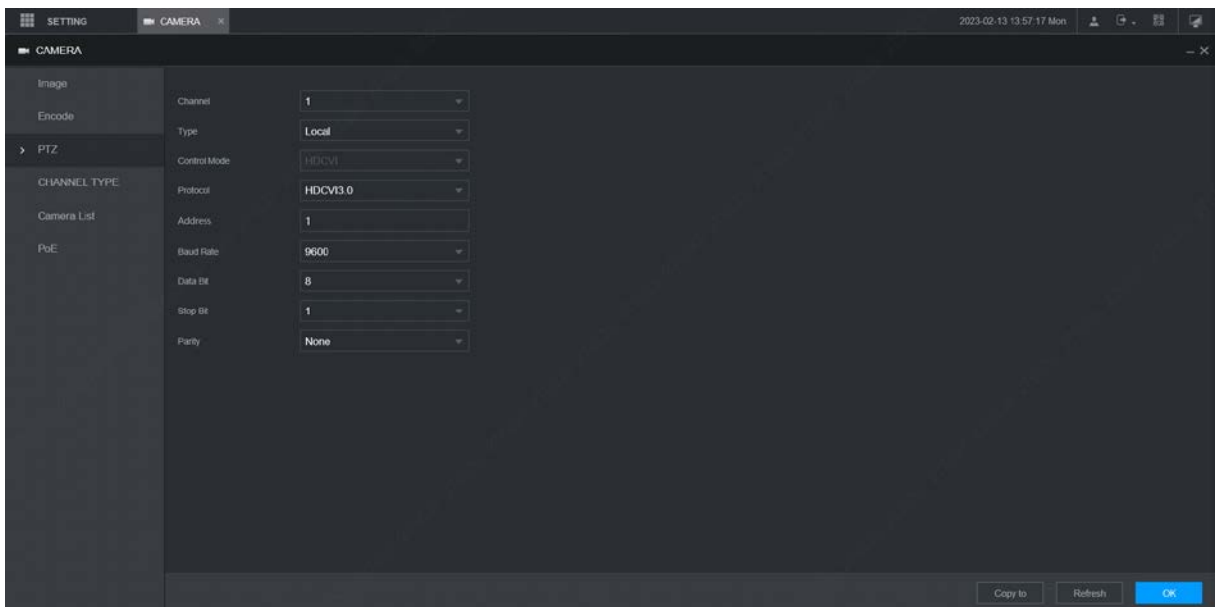



Figure 5-48 PTZ



**Step 2** Select a channel.

**Step 3** Configure more parameters. See Table 5-16.

Table 5-16 PTZ parameters

Parameter	Description
PTZ type	Set the PTZ type, including local and remote.
Control mode	PTZ controlling mode.  If <b>Local</b> is selected for PTZ type, configure this parameter.
Protocol	Select the PTZ protocol, including NONE, HDCVI3.0 and HDCCTV2.0.  If <b>Local</b> is selected for PTZ type, configure this parameter.
Address	Set the PTZ address.  If <b>Local</b> is selected for PTZ type, configure this parameter.
Baudrate	The times of signal changes on the transmission line within one time unit. <ul style="list-style-type: none"> <li>• The default baudrate is 115200 for a console.</li> <li>• The default baudrate is 9600 for a vehicle light box.</li> </ul>  If <b>Local</b> is selected for PTZ type, configure this parameter.
Data bits	Select a data bit. The options include <b>5, 6, 7, and 8</b> .  If <b>Local</b> is selected for PTZ type, configure this parameter.
Stop bits	Select a stop bit. The options include <b>1, 1.5, and 2</b> .  If <b>Local</b> is selected for PTZ type, configure this parameter.
Parity	Select a parity mode from None, Odd, Even, Mark, and Null.  If <b>Local</b> is selected for PTZ type, configure this parameter.

Step 4 Click **OK**.

## 5.5.4 Channel Type

You can configure the corresponding type of the device channel.

Step 1 Select SETTING > CAMERA > CHANNEL TYPE.

The **CHANNEL TYPE** interface is displayed.



Figure 5-49 CHANNEL TYPE

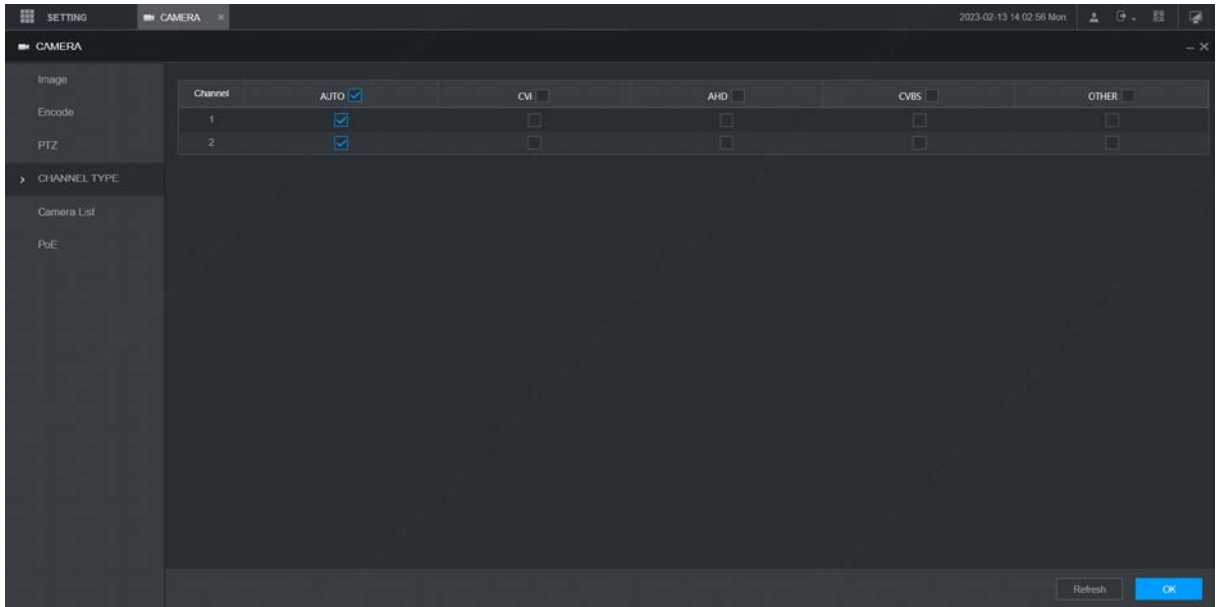

**Step 2** Select channel type and click **OK**.

## 5.5.5 PoE

View the connection status of the PoE port and reset the camera.

**Step 1** Select **SETTING > CAMERA > PoE** in the main menu. The **PoE** interface is displayed.

Figure 5-50 PoE

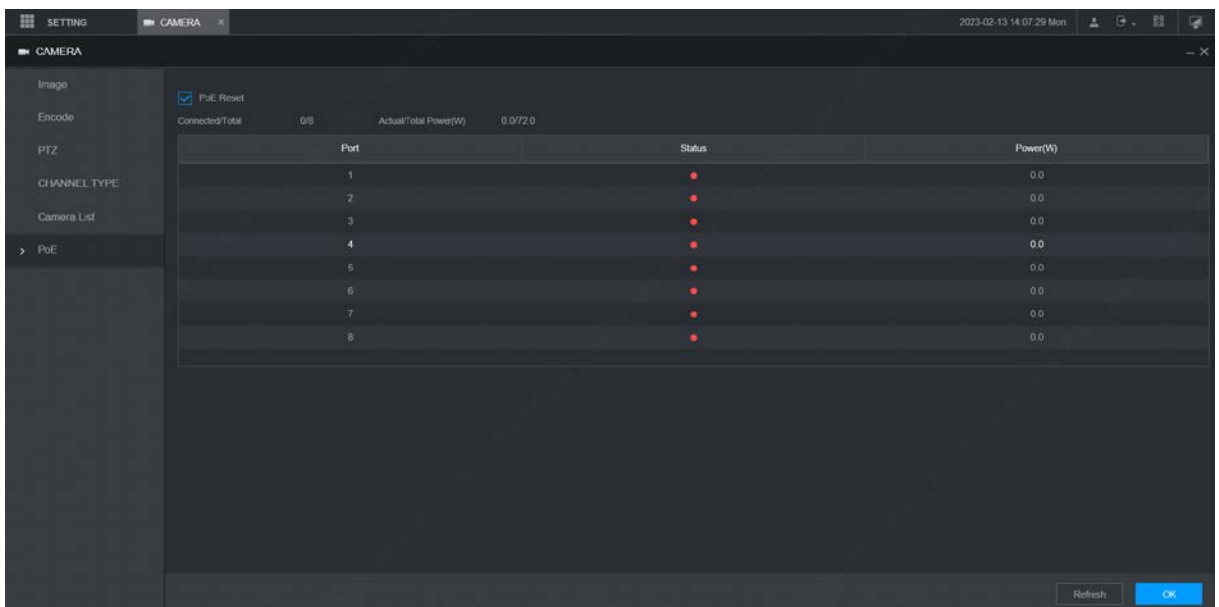

**Step 2** Select **PoE Reset**, and click **Apply** to reset the camera with power but offline so that the camera can be online. If the camera is still offline after reset for 3 times, the system will not reset again.



When the total power of the cameras accessed through PoE exceeds the maximum power of the device, the device will force the camera connected to the maximum port number to go offline until the total power of the camera accessed through PoE does not exceed the maximum power of the device.

## 5.6 Configuring Network Parameters

You can set the network parameters of the device as needed, including port, Wi-Fi parameters, cellular parameters, email, register, P2P and operation platform.

### 5.6.1 Port

You can configure the maximum number of ports and their respective values.

**Step 1** Select **SETTING > NETWORK > Port**.

The **Port** interface is displayed.

Figure 5-51 Port

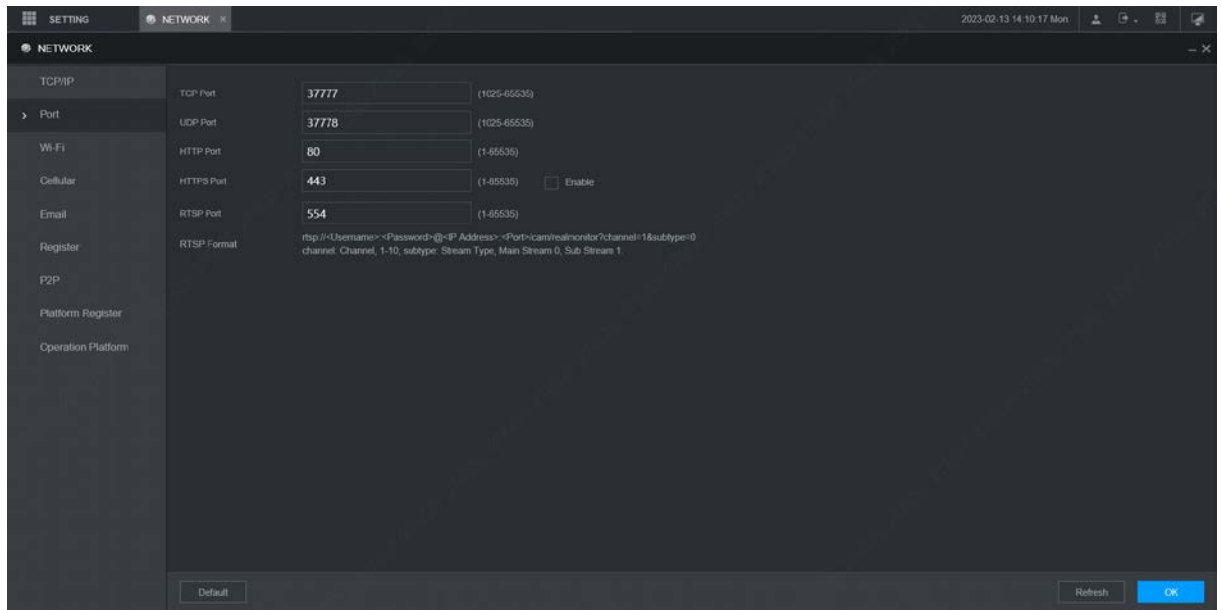

**Step 2** Configure the ports of the device.



The revised settings take effect after device restart. Proceed with caution.

Table 5-17 Port parameters

Parameter	Description
TCP port	Transmission Control Protocol port. The value is 37777 by default.
UDP port	User Datagram Protocol port. The value is 37778 by default. You can enter the value as needed.
HTTP port	Hyper Text Transfer Protocol port. The value is 80 by default. You can enter other values as needed, in which case, add the new value after the address when logging in to the device in the browser.
HTTPS port	Hyper Text Transfer Protocol over Secure Socket Layer port. Select <b>Enable</b> , and then enter the value as needed. The value is 443 by default.

RTSP port	<ul style="list-style-type: none"> <li>● Real Time Streaming Protocol port. Keep the default value 554 if it is displayed. If you use Apple browser, QuickTime or VLC to play the real-time monitoring screen, the following formats can be used: This function is also available for Blackberry phones.</li> <li>● When the URL format requiring RTSP, you need to specify channel number and code-stream type in the URL, and also user name and password if needed.</li> <li>● When playing live view with Blackberry smart phone, you need to turn off the audio, and then set the compression to H.264B and resolution to CIF.</li> </ul> <p>URL format:  rtsp://&lt;User Name&gt;:&lt;Password&gt;@&lt;IP Address&gt;:&lt;Port&gt;/cam/realmonitor?channel=1&amp;subtype=0</p> <ul style="list-style-type: none"> <li>● User name, such as admin.</li> <li>● Password, such as admin_123.</li> <li>● IP address, such as 192.168.1.16.</li> <li>● Port: The default setting is 554. If the default setting is displayed, you do not need to configure this parameter.</li> <li>● Channel: channel number, starting from 1. For example, if it is channel 2, enter channel=2.</li> <li>● Subtype: code-stream type. The main stream is 0 (subtype=0); the sub stream is 1 (subtype=1).</li> </ul> <p>For example, if you request the sub stream of channel 2 from a certain device, the URL should be:  rtsp://admin:admin_123@192.168.1.16:554/cam/realmonitor?channel=2&amp;subtype=1</p> <p>If certification is not required, there's no need to specify the user name and password. Use the following format:  rtsp:// &lt;IP Address&gt;:&lt;Port&gt;/cam/realmonitor?channel= 1&amp;subtype=0</p>
NTP port	The port that automatically syncs time with the NTP server is 123 by default.

Step 3 Click **OK**.

## 5.6.2 Wireless Network

You can connect the device to a network through Wi-Fi. Make sure the device can communicate with other devices in the group network. The device itself can also act as a hot spot to share flows with other terminals.



If both 3G/4G and Wi-Fi are available, the device connects to Wi-Fi and disconnects from 3G/4G.

### 5.6.2.1 Wi-Fi Network

You can connect the device to a network through Wi-Fi. Then connect the PC to the same network. You can log in to the web interface by PC to operate the device.



This function is only supported by the device with a Wi-Fi module. The actual situation shall prevail.

## Preparation

Make sure that the device is connected to a Wi-Fi module.

## Procedure

**Step 1** Select SETTING > NETWORK > Wi-Fi.

The **Wi-Fi** interface is displayed.

**Step 2** Select **Wifi** as the working mode.

The **Wi-Fi** interface is displayed.

Figure 5-52 Wi-Fi

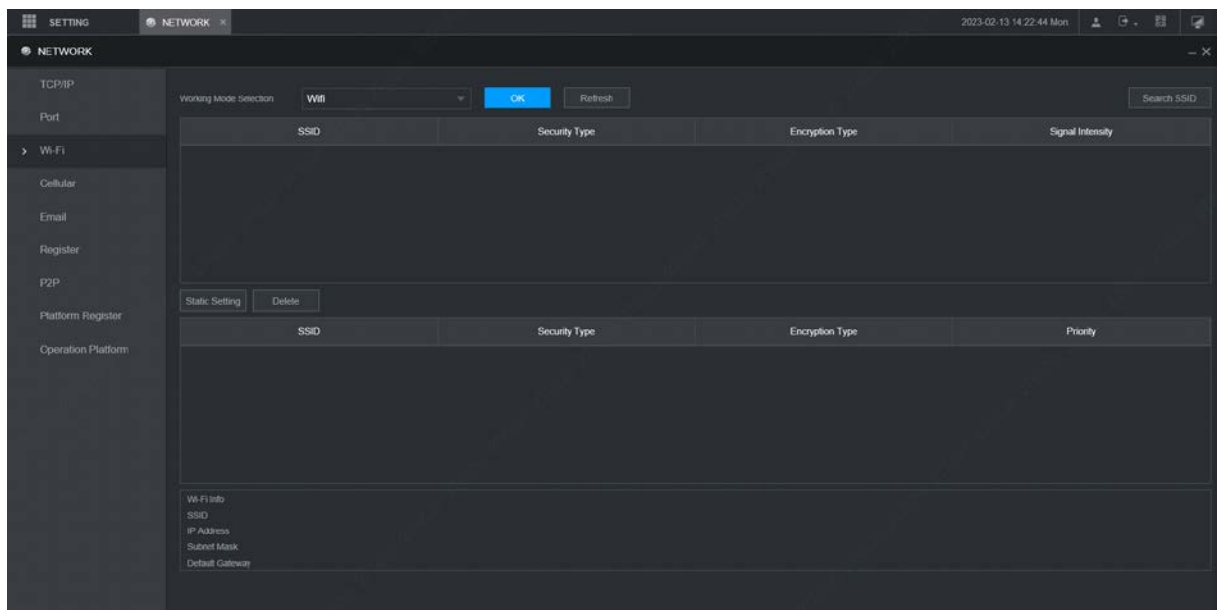

**Step 3** Connect to Wi-Fi.

- Auto search
  1. Click **Search SSID**.  
In the SSID list, all available wireless networks are listed, including the information such as network name, security type, encryption type, and signal intensity.
  2. Double-click the Wi-Fi you want to connect to, enter the password, and then click **OK**.
- Add Wi-Fi manually.
  1. Click **Static Setting**.  
The **Wi-Fi** interface is displayed.

Figure 5-53 Wi-Fi settings

Wi-Fi

SSID

Connection Status: No Connection

Priority: 1

Verification: WPA2-PSK

Authentication: AES

Input Password

IP Address: 0 . 0 . 0 . 0  DHCP

Subnet Mask: 0 . 0 . 0 . 0

Default Gateway: 0 . 0 . 0 . 0

Save Cancel

2. Enter SSID and password, select priority and verification type, set IP address, subnet mask, and gateway.  
If you select **DHCP** check box, after successful connection, the system automatically obtains the IP address, subnet mask, and gateway.
3. Click **OK**.

**Step 4** Click **OK**.

Click **Refresh** to refresh the connection status.

After successful connection, you can view the current hot spot, IP address, subnet mask, and gateway in **Wi-Fi Working Info**.

### 5.6.2.2 Wi-Fi Hot Spot

The device can work as a hot spot to share the network connection to other terminals. The terminals connected to the hot spot can log in to the device through host IP address (192.168.0.108). After login, you can view videos on the device.

**Step 1** Select **SETTING > NETWORK > Wi-Fi**.

The **Wi-Fi** interface is displayed.

**Step 2** Select **Ap** as the working mode.

The **Ap** interface is displayed.

Figure 5-54 Ap settings

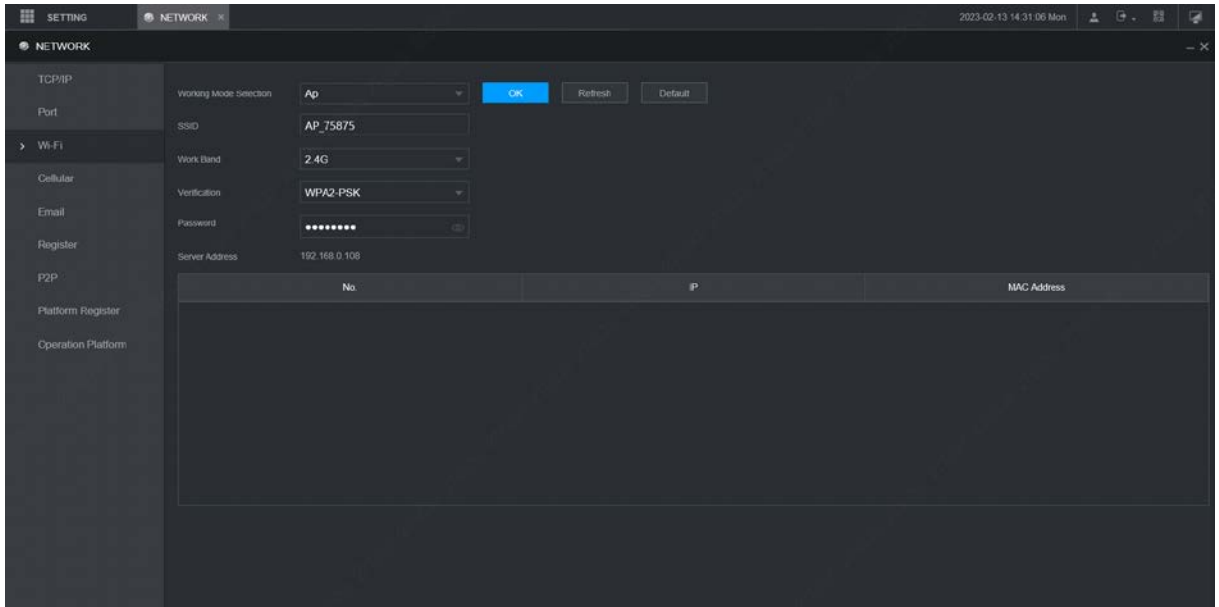

**Step 3** Enter SSID, select work band and verification type, and then enter the password.

- The work band can only be 2.4G.
- Select the check box behind **Password**, and the password will be visible. The default password is 12345678.

**Step 4** Click **OK**.

## 5.6.3 Cellular

### Prerequisites

- Make sure that the device is equipped with cellular module and inserted with SIM card from corresponding communication operators.
- The dial number, user name, and password have been obtained from corresponding communication operators.

### Procedure

**Step 1** Select SETTING > Network > Cellular.

The **Cellular** interface is displayed. See Table 5-19.



After Cellular module is connected, the module information and wireless signal are displayed; if not, click **Search** to search for wireless signal.

Figure 5-55 Cellular settings

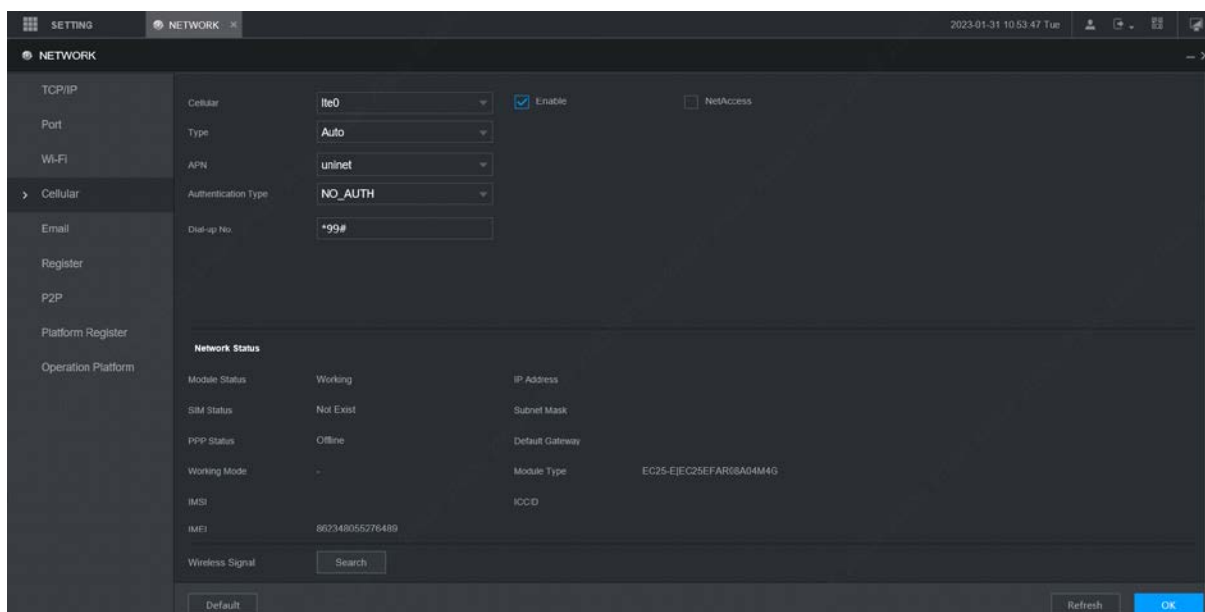

**Step 2** Select **lte0** and **Enable** to enable the network. This function is enabled by default.

**Step 3** Configure parameters. For details, see Table 5-18.

Table 5-18 Cellular setting parameters description

Parameter	Description
NetAccess	When the Device is accessed to private network, select the <b>NetAccess</b> check box, enter APN name and select authentication mode. If <b>PAP</b> or <b>CHAP</b> is selected for authentication mode, enter user name and password, then the device is automatically accessed to private network.
Type	When enabled, the network type is displayed, which is used to distinguish between the 3G/4G modules of different communication operators, such as TD-LTE.
APN	Displays access point of Communication Operator. To manually set up <b>APN</b> , select <b>Customized</b> .
Authentication Type	Includes PAP, CHAP, and NO_AUTH protocols. The system automatically recognizes and displays the enabled protocol.
Dial-up No	Enter the dial number provided from the Communication Operator.
User Name	This parameter needs to be set up when AUTH is set to PAP or CHAP.
Password	The system automatically recognizes the user name and password.
Network Status	After successful dial-up, all relevant information is displayed without any setup needed. Such information includes module status, SIM status, PPP status, working mode, IMSI, IMEI, IP address, subnet mask, gateway, and module type.
Wireless Signal	Click <b>Search</b> to search for wireless signals.

**Step 4** Click **OK**.

After access is succeeded, the obtained IP address is displayed.

## 5.6.4 Email

You can configure the email settings to enable the system to send the email as a notification when there is an alarm event occurs, such as video detection and system events.

**Step 1** Select SETTING > Network > Email.

The **Email** interface is displayed. See Figure 5-56.

Figure 5-56 Email

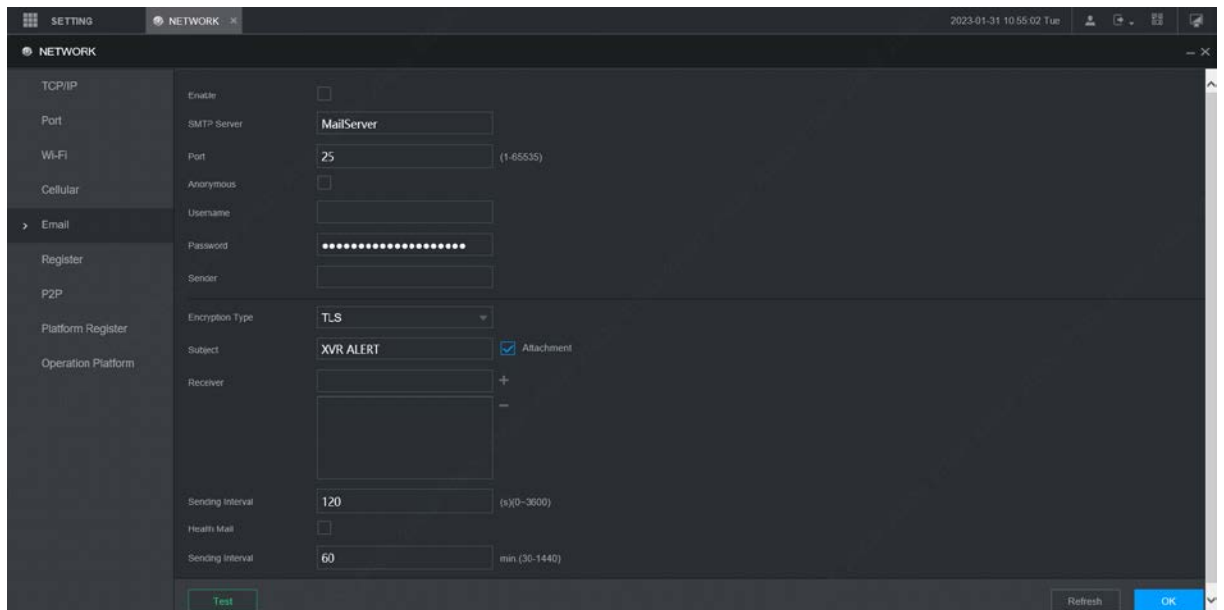

**Step 2** Select **Enable** to enable email function.

**Step 3** Configure parameters. For details, see Table 5-19.

Table 5-19 Email parameters description

Parameter	Description
SMTP server	Configure the address of Simple Mail Transfer Protocol.
Port	Enter the port value of SMTP server.
Anonymous	If <b>Anonymous</b> is selected, the sender information is not displayed when sending an email.
User Name	Enter the user name and password of SMTP server.
Password	
Sender	Email address of sender.
Encryption Type	In the Encrypt list, select an encryption type from None, SSL, and TLS.
Subject	You can enter no more than 63 characters in Chinese, English, and Arabic numerals.
Attachment	If <b>Attachment</b> is enabled, when an alarm takes place, the system can send alarm linked snapshots.
Receiver	Receiver's Email address. You can enter up to three email addresses separated by colons.
Sending Interval	This is the interval that the system sends an email for the same type of alarm event, which means, the system does not send an email upon any alarm event. The interval ranges from 0 through 3600 seconds. 0 means that there is no interval.
	 This setting helps to avoid the large amount of emails caused by frequent alarm events.



Parameter	Description
Health Mail	The system can send a test email to check the connection. Select the <b>Health Mail</b> check box, and then enter the interval. The system can send a test email to check the connection after the specified interval.  The interval ranges from 30 minutes to 1440 minutes.
Test	Click <b>Test</b> to test if emails can be sent out and received as intended. If the configuration is correct, the receiver's email account will receive the test email. Before testing email, click <b>OK</b> to save the email configuration.

**Step 4** Click **OK**.

## 5.6.5 Register

After successfully auto registered, when the device is connected into the Internet, it will report the current location to the specified server to make it easier for the client software to access to the device, and to view and monitor it.

**Step 1** Select SETTING > Network > Register.

The **Register** interface is displayed. See Figure 5-57.

Figure 5-57 Register

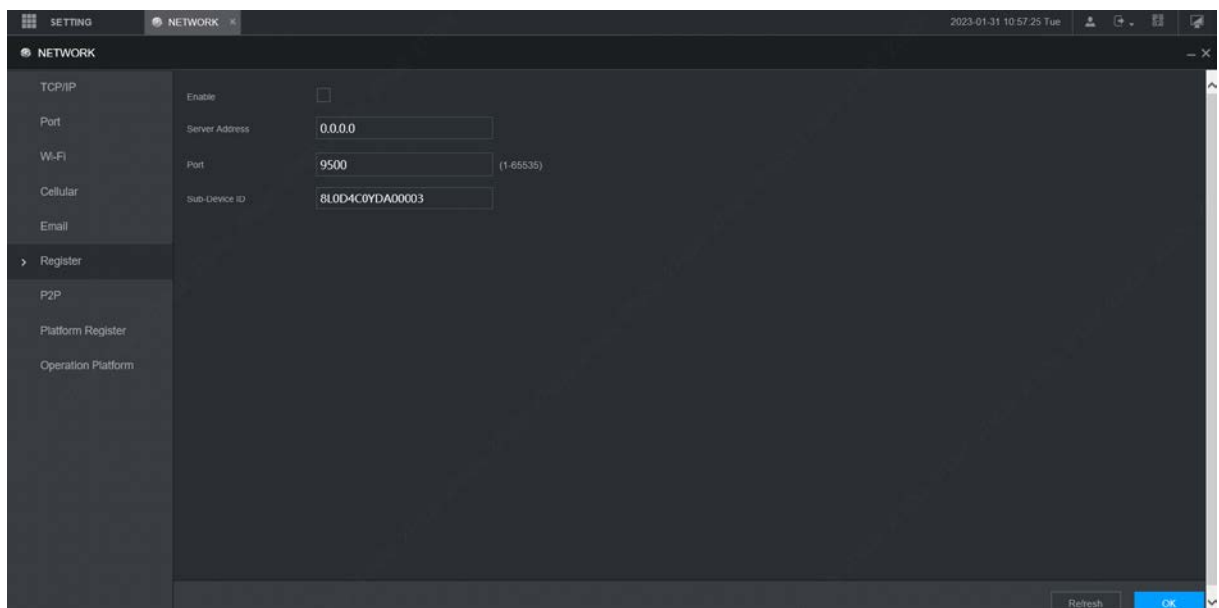

**Step 2** Select the **Enable** check box. (Selected by default)

**Step 3** Configure parameters. For details, see Table 5-20.

Table 5-20 Register Parameters

Parameter	Description
Server Address	Enter the IP address or domain name of the server to register.
Port	The port for auto-registration.
Sub-device ID	Unique ID for identifying the device. When different devices register to the same server, the sub-device IDs should be different.

**Step 4** Click **OK**.

## 5.6.6 P2P

P2P is a private network penetration technology. With this technology, you do not need to apply for dynamic domain name, set port mapping, or deploy transit server. You can add devices for management by either of the following two ways.

- Scan the QR code on the interface to download the app, and register an account.
- Log in [www.gotop2p.com](http://www.gotop2p.com) platform to register, and then add devices by device serial number.



Before using P2P, make sure that the device is connected to the Internet.

### Prerequisites

- The device had been connected to the Internet.
- App has been downloaded and installed on the mobile phone.

### Procedure

**Step 1** Select **SETTING > Network > P2P**.

The **P2P** interface is displayed, see Figure 5-58.

Figure 5-58 P2P

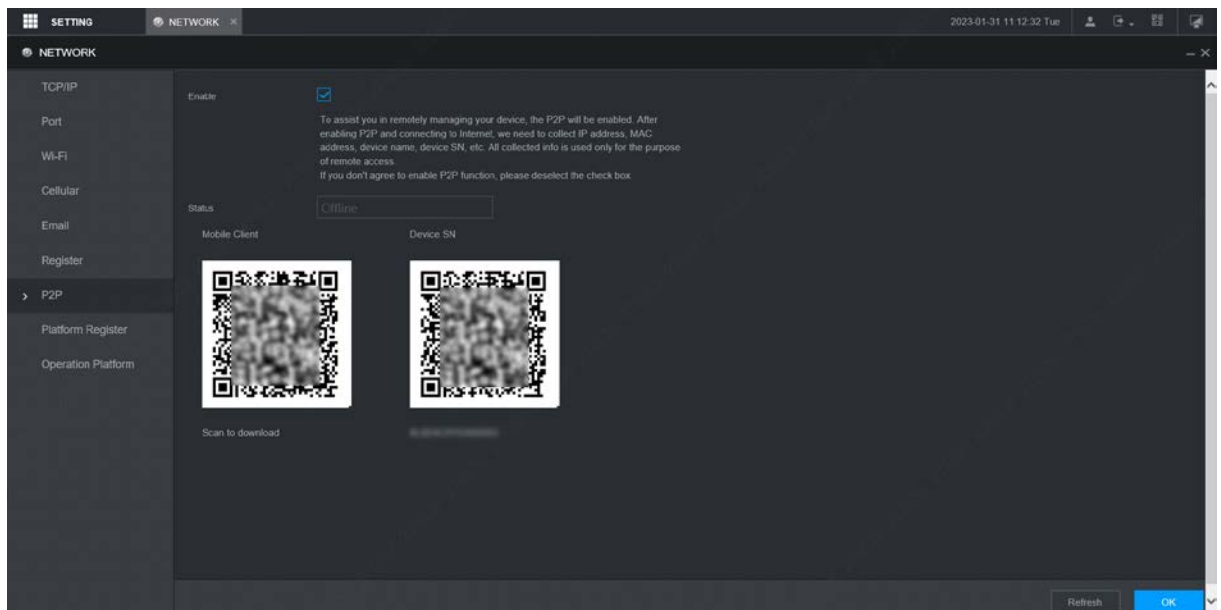

**Step 2** Select **Enable** to enable P2P.

**Step 3** Click **OK**.

The P2P registration is successful when the **Status** shows **Online**.

**Step 4** Use Mobile Client to scan the QR code under Device SN to add the device to Mobile Client.



Please scan the QR code on the actual interface of device.

## 5.6.7 Operation Platform

By connecting to the operation platform, you can modify the configuration information of the recorder, collect the print information and GPS raw data, and upgrade remotely.

**Step 1** Select **SETTING > NETWORK > Operation Platform**.

The **Operation Platform** interface is displayed. See Figure 5-59.

Figure 5-59 Operation Platform

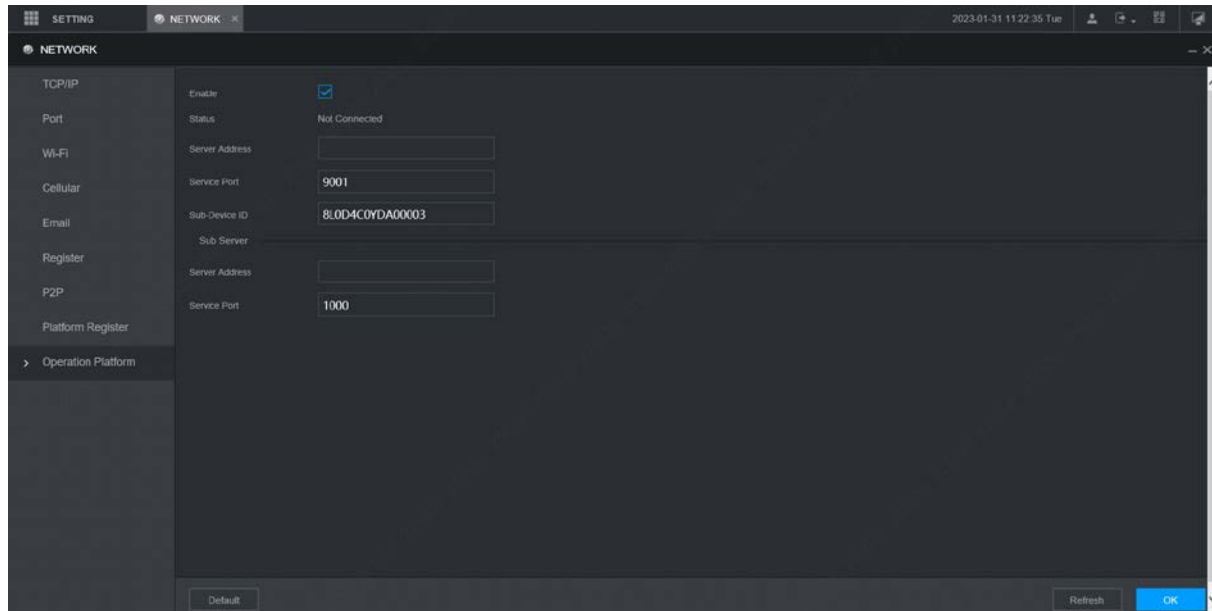

**Step 2** Select **Enable**.

**Step 3** Configure parameters. For details, see Table 5-21.

Table 5-21 Operation platform parameters

Parameter	Description
Server IP Address	Enter the IP address or domain name of the server to register.
Server Port	Enter the port of the server to register.

**Step 4** Click **OK**.

## 5.7 Managing Storage Device

You can configure storage, basic information, manage HDD, and review HDD information.

### 5.7.1 Basic

On the Local interface, you can set up the strategy when the Disk is full and recording mode.

**Step 1** In the main menu, select **Setting > Storage > Basic**.

The **Basic** interface is displayed. See Figure 5-60.

Figure 5-60 Basic

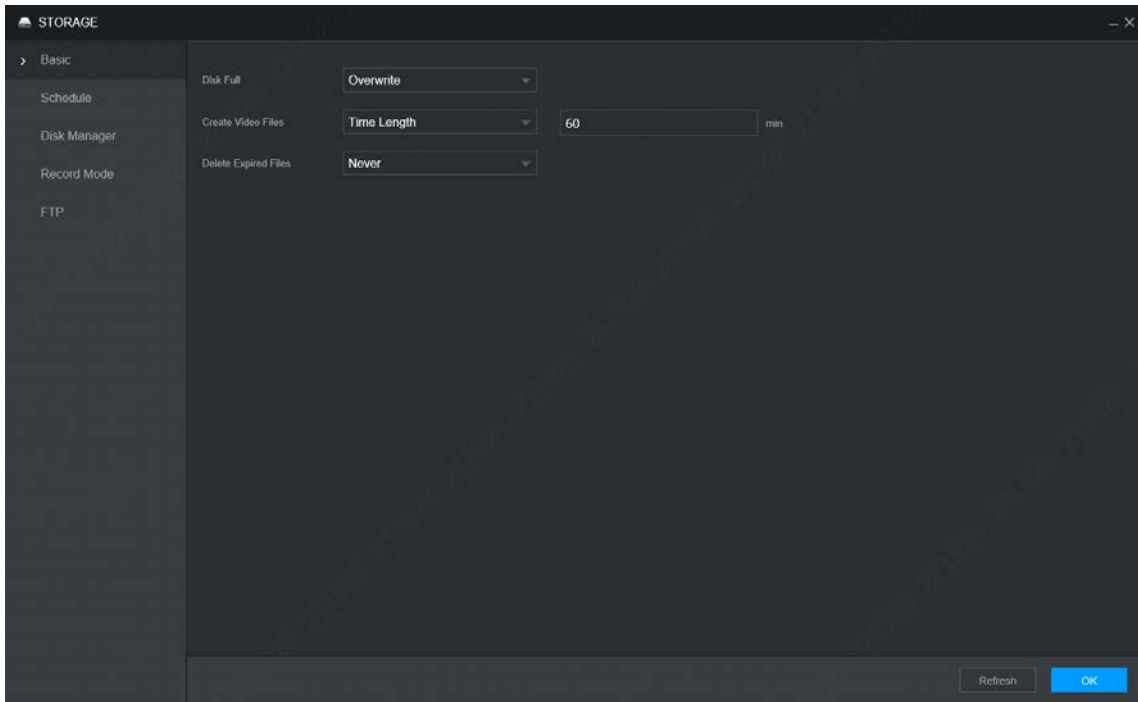

**Step 2** Configure basic information.

- Select the processing strategy of stopping recording and overwriting earlier recordings when TF Card is full.
  - ◇ **Stop:** The system stops recording when the disk is full.
  - ◇ **Overwrite:** The system overwrites the oldest files and keeps recording when the disk is full.
- Set up the time length or file size for video packaging.  
Select the required packaging manner from the **Create Video Files** drop-down list. Including **Time Length** and **File Size**.
  - ◇ Set the length of time for each video file. The default value is 60 minutes, and the range is 1 minute –120 minutes.
  - ◇ Set the size of file for each video file. The default value is 1024M, and the range is 128M –2048M.
- Set the strategy of deleting old files automatically.  
You can enable this function to delete recorded videos or images saved in TF card or FTP server regularly according to the time gap you have set.



After setting file auto deletion, deleted files cannot be recovered.

**Step 3** Click **OK**.

## 5.7.2 Disk Manager

Set the read and write properties of the TF card and view the capacity information of the HDD.

**Step 1** Select SETTING > Storage > Disk Manager.

The **Disk Manager** interface is displayed. See Figure 5-61.

**Step 2** Set the read and write properties of the TF card. You can set the TF card as the Read/Write disk, Read-Only disk or Redundancy disk under the **Properties** column.

- Read/Write: You can read data from TF card and save data in TF card.

- Read-Only: You can only read data from TF card if set to read-only disk.
- Redundancy: If the device is connected to two or more TF cards, one of the TF cards can be set as the redundancy one for recording backup.



Select TF card and click **Format** to clear all data in the TF card. Proceed with caution.

Figure 5-61 Disk Manager

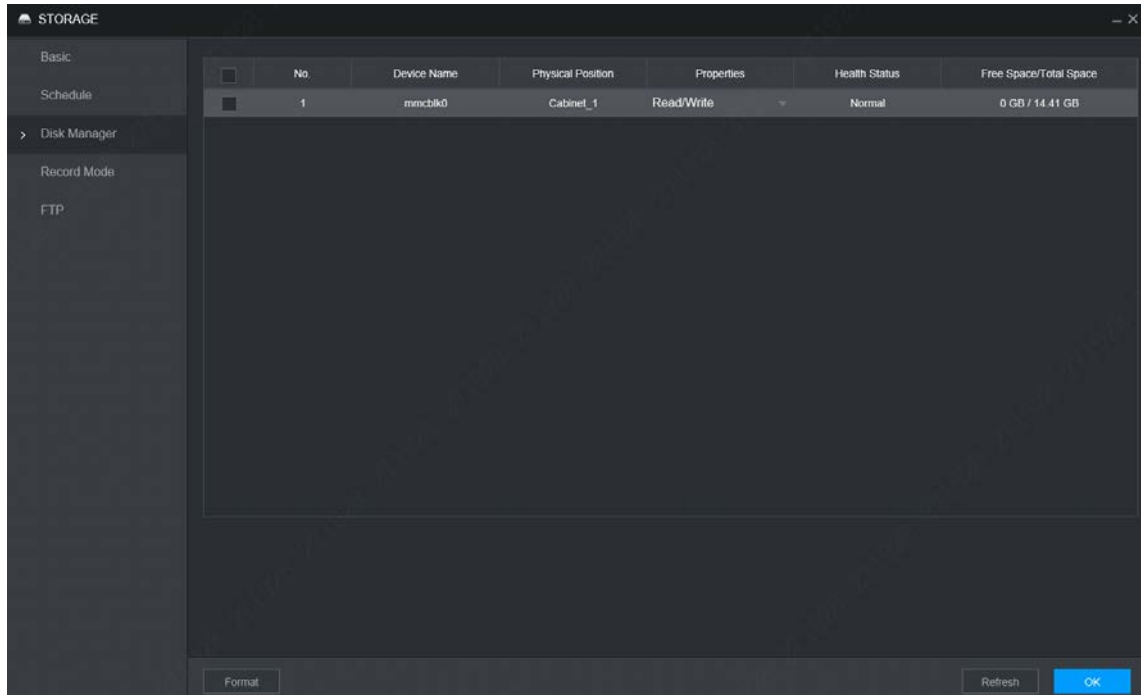

Step 3 Click **OK**.

### 5.7.3 FTP

Configure FTP server, and then you can save videos and snapshots to the FTP server.

#### Prerequisites

You have deployed a FTP server, and created a user with the read & write permission.



The created FTP user should have write permission; otherwise the upload of videos, audios, and snapshots will be failed.

#### Procedure

- Step 1 Select SETTING > Storage > FTP.  
The **FTP** interface is displayed, see Figure 5-62.

Figure 5-62 FTP

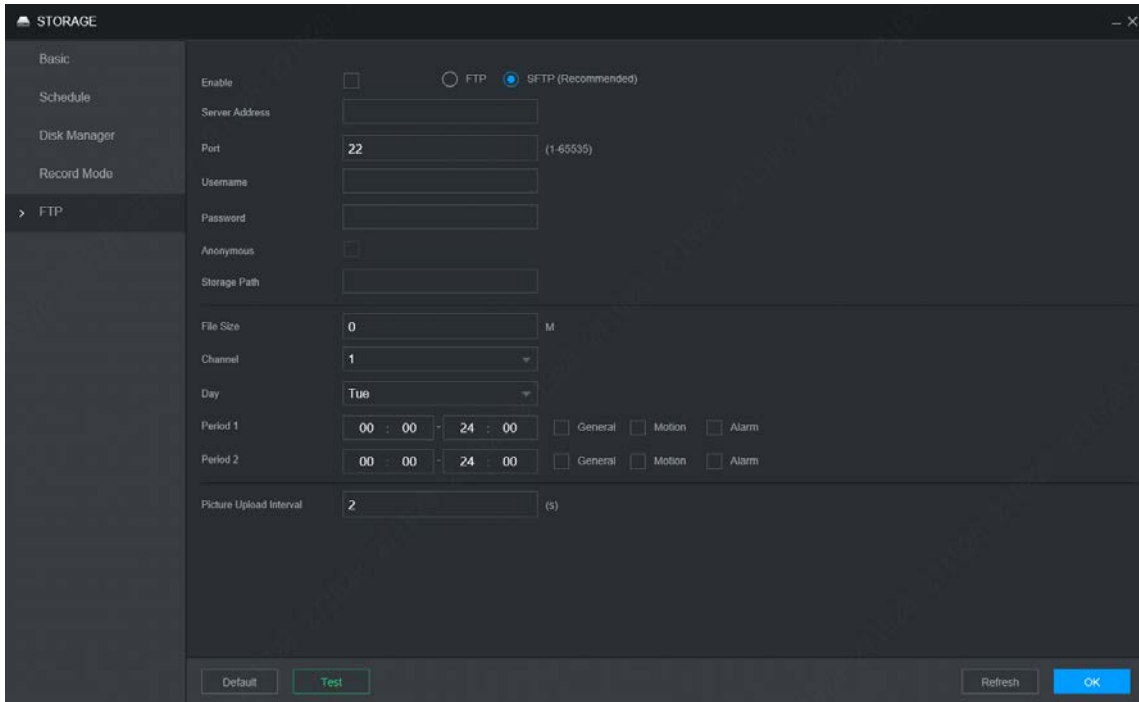

**Step 2** Select **Enable** to enable FTP upload and select FTP type.



- You select FTP or SFPT from the drop-down list. SFTP is recommended to enhance network security.
- When **FTP** is selected, the system gives a risk prompt. Select **OK** or **Cancel** as needed.

**Step 3** Configure parameters. For details, see Table 5-22.

Table 5-22 FTP parameter description

Parameter	Description
Server Address	The IP address of the host PC that is installed with the FTP/SFTP server.
Port	By default, SFTP port is 22 and FTP port is 21.
User Name	The user name and password used to access the server.
Password	
Anonymous	Select <b>Anonymous</b> if you want to log in to the server anonymously.
Storage Path	<p>Create folder on FTP server.</p> <ul style="list-style-type: none"> <li>• If you do not enter the name of remote directory, the system automatically creates the folders according to the IP, time, and channel.</li> <li>• If you enter a name for the remote directory, the system creates a folder with the entered name under the FTP/SFTP root directory first, and then automatically creates folders based on IP, time, and channel.</li> </ul>
File Size	<p>Enter the size of the uploaded recorded video.</p> <ul style="list-style-type: none"> <li>• If the entered size is less than the recorded video size, only a section of the recorded video can be uploaded.</li> <li>• If the entered size is more than the recorded video size, the whole recorded video can be uploaded.</li> <li>• If the entered size is 0, the whole recorded video will be uploaded.</li> </ul>
Choose channel	Select the channel that you want to apply the FTP settings.

Parameter	Description
Weekday	Select the week day and set the time period that you want to upload the recorded files. You can set two periods for each week.
Period	Select the record type (Alarm, MD, and General) that you want to upload. After selecting the corresponding recording type next to the corresponding period, the selected recording type will be uploaded during the configured period.
Picture Upload Interval	<ul style="list-style-type: none"> <li>● When the <b>Snapshot Type</b> is <b>Schedule</b>, the upload method should be determined based on the image upload interval and snapshot interval. <ul style="list-style-type: none"> <li>◇ If this interval is longer than snapshot interval, the system uploads the most recent snapshot. For example, if the interval is 5 seconds and snapshot interval is 2 seconds, the system sends an upload command to upload the next snapshot every 5 seconds.</li> <li>◇ If this interval is shorter than snapshot interval, the system uploads the snapshot per the snapshot interval. For example, if the interval is 5 seconds and snapshot interval is 10 seconds, the system uploads the snapshot every 10 seconds.</li> </ul> </li> <li>● When the <b>Snapshot Type</b> is <b>Event</b>, the system uploads the snapshot as per the snapshot interval.</li> </ul>  <p>You can change the <b>Interval</b> and <b>Type</b>. For details, see "5.5.2.2Snapshot".</p>

**Step 4** Click **Test** to test if the FTP/SFTP server is successfully configured.

- The system pops up a message to indicate success or failure.
- If failed, please check the network connection or configurations.

**Step 5** Click **OK**.

## 5.8 Configuring System

You can configure system information, including serial port, security, and vehicle information.

### 5.8.1 Configuring Serial Port Parameters

You can configure the RS-232 serial port parameters such as baud rate, data bit, stop bit, and parity.

**Step 1** Select SETTING > System > Serial Port.

The **Serial Port** interface is displayed. See Figure 5-63.

Figure 5-63 Serial Port

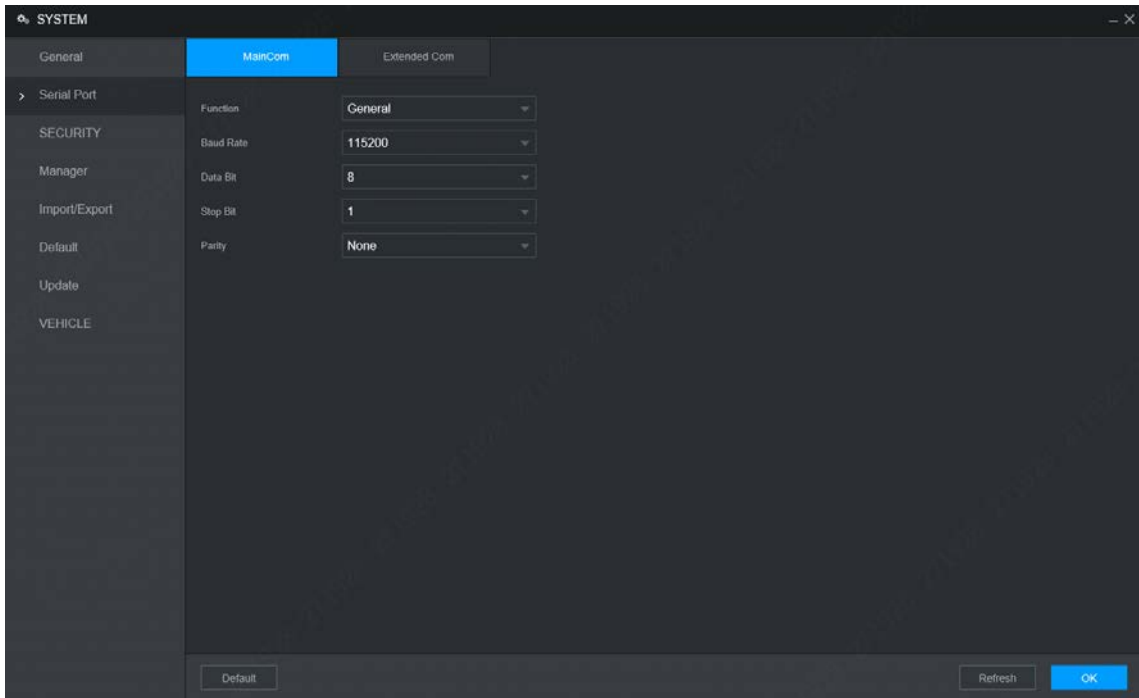

**Step 2** Configure parameters. For details, see Table 5-23.

Table 5-23 Serial port setting parameters description

Parameter	Description
Function	Select the corresponding protocol. <ul style="list-style-type: none"> <li>● Console: Upgrades programs and debug by suing the serial interface and mini terminal software.</li> <li>● GPS: Used to transmit real-time GPS data.</li> </ul>
Baudrate	The times of signal changes on the transmission line in time unit. <ul style="list-style-type: none"> <li>● The default baud rate is 115200 for a console.</li> <li>● The default baud rate is 9600 for a transparent serial port.</li> </ul>
Data Bit	Select a data bit. The options include <b>5,6,7, and 8</b> .
Stop Bit	Select a stop bit. The options includes <b>1, 1.5, and 2</b> .
Parity	Select a parity mode from None, Odd, Even, Mark, and Null. The default is <b>None</b> .

**Step 3** Click **OK**.

## 5.8.2 Managing Security

It is to set security strategy to guarantee device network and data safety. It includes setting host IP access right and enabling system service, etc.

### 5.8.2.1 System Service

The corresponding service can only be used after the system service is turned on.

**Step 1** Select **SETTING > System > Security > System Service**.

The **System Service** interface is displayed. See Figure 5-64.



Figure 5-64 System service

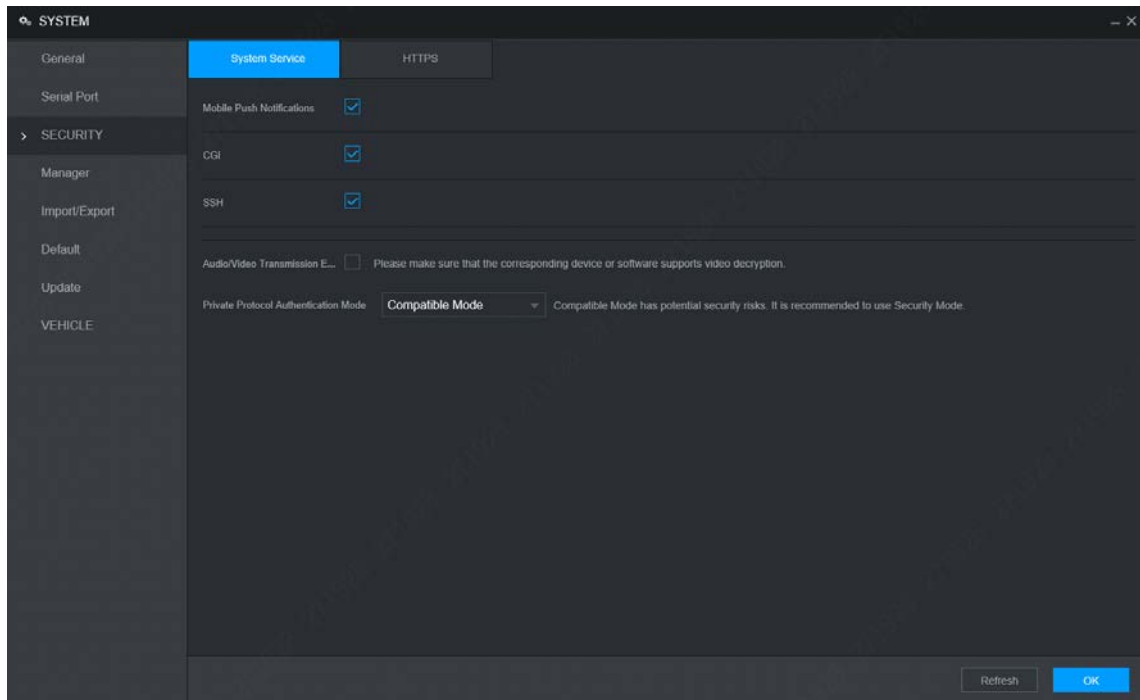

**Step 2** Select whether to enable mobile phone push, CGI, SSH, or audio/video transmission encryption as needed.

- App can receive alarm push only when the mobile phone push is enabled and the app has subscribed alarm.
- After enabling CGI, other platform can connect to this device via the CGI protocol.
- When audio/video transmission encryption is enabled, audio/video transmission will be encrypted. Related devices or software shall support video decryption.

**Step 3** Click **OK**.

## 5.8.3 Configuring Vehicle Info

You can set the vehicle speed ratio and position report.

### 5.8.3.1 Configuring Speed

**Step 1** Select **SETTING > System > Vehicle > Speed**.  
The **Speed** interface is displayed. See Figure 5-65.

Figure 5-65 Speed

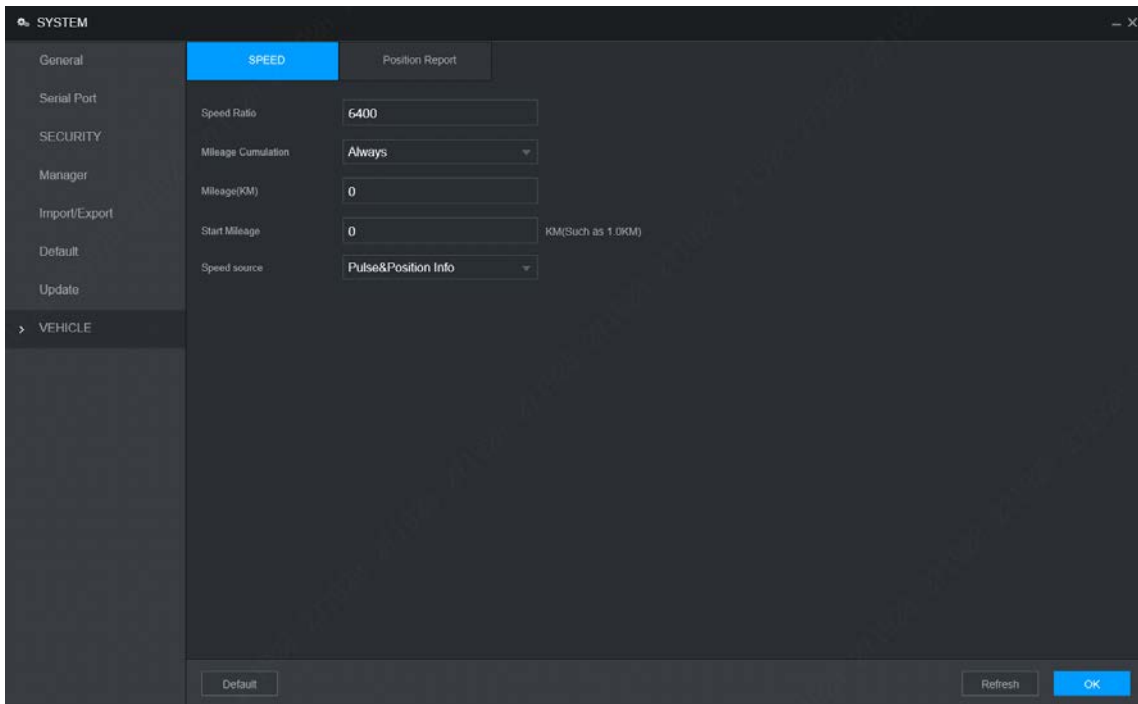

**Step 2** Configure parameters. For details, see Table 5-24.

Table 5-24 Speed parameters description

Parameter	Description
Speed Ratio	The parameter for converting speed.
Mileage Cumulation	Select the vehicle mileage cumulation mode.
Mileage	Displays the total mileage.
Start Mileage	Enter the initial mileage of the vehicle.
Speed source	Select where the speed is obtained, including <b>Pulse</b> , <b>Position Info</b> , and <b>Pulse&amp;Position Info</b> . <ul style="list-style-type: none"> <li>● Pulse: Get the speed information from vehicle pulse system.</li> <li>● Position Info: Get the speed information from positioning system.</li> <li>● Pulse&amp;Position Info: Gets the speed information from both the pulse system and positioning system. Information from the pulse system is used first.</li> </ul>

**Step 3** Click **OK**.

### 5.8.3.2 Configuring Position Report

You can configure the position report strategy to be device auto report or report per platform schedule.

**Step 1** Select **SETTING > System > Vehicle > Position Report**.

The **Position Report** interface is displayed. See Figure 5-66.

**Step 2** Configure the report strategy.

- Device auto report.
  - In the **Report Strategy** list, select **Device Auto**.  
The **Device Auto** setting interface is displayed. See Figure 5-66.

Figure 5-66 Position report (device auto)

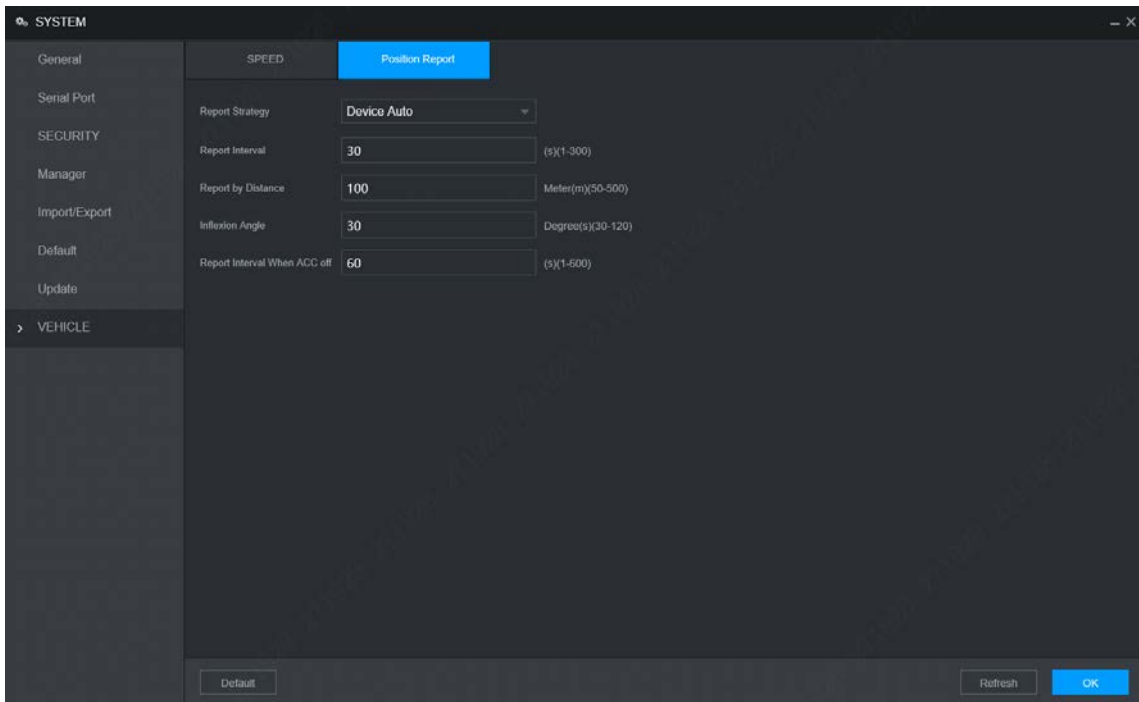

5. Configure parameters. For details, see Table 5-25.

Table 5-25 Device auto report parameters description

Parameter	Description
Report Interval	When the vehicle ACC status is on, the system report the position to platform according to the configured report interval, report distance, and inflexion angle.
Report by Distance	
Inflexion Angle	
Report Interval When ACC off	When the vehicle ACC status is off, the system report the position to platform according to the configured report interval.

- Platform schedule.

In the **Report Strategy** list, select **Platform Schedule**. The **Platform Schedule** setting interface is displayed. See Figure 5-67.

The platform obtains the device position by the configured schedule. The schedule is configured at the platform. See the user's manual for the platform.

Figure 5-67 Position report (platform schedule)

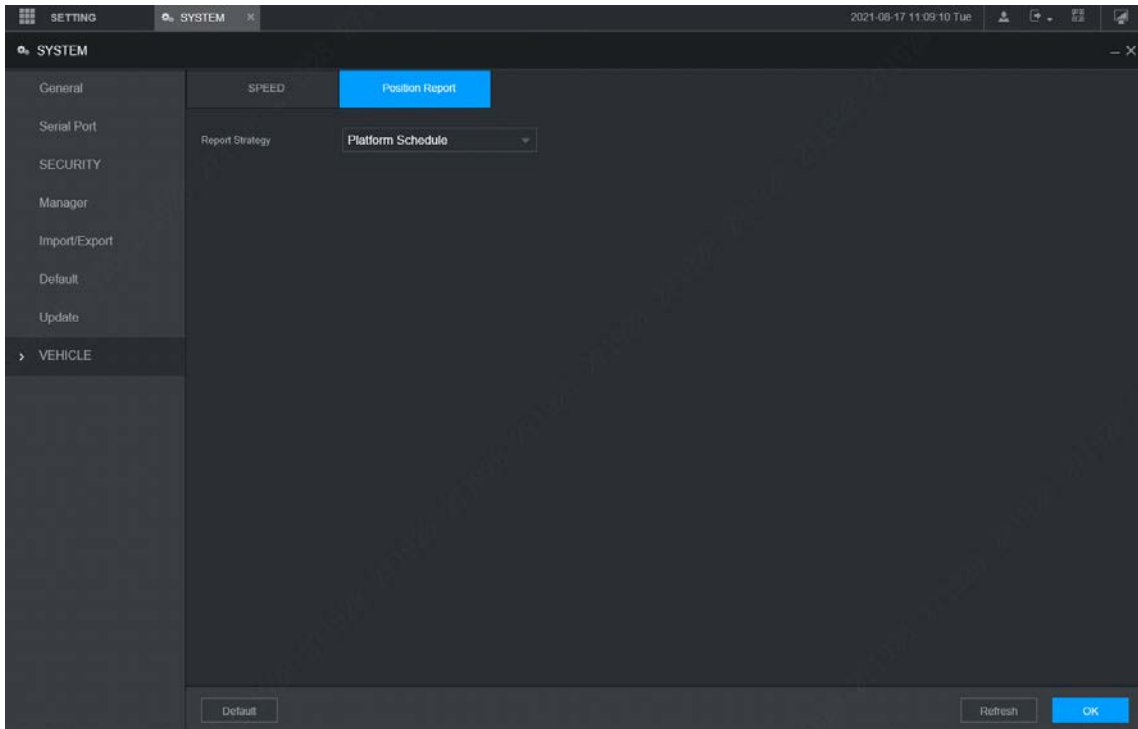

Step 3 Click **OK**.

## 5.9 Managing User Account

You can add, modify and delete user accounts and groups, and configure security questions for admin account.

### The Default User and Authority

The default user account is admin.

- The admin account is defined as the highly privileged user by default.
- To manage user accounts easily, when defining the user account authority, it is recommended to give lower authority to common user accounts than advanced user account.

### About User and User Group

You can manage the account by user and user group, and the name cannot be repeated.

- You can set maximum 64 users and 20 groups.
- The default group name by "User" and "Admin" cannot be deleted.
- Select the authorities to the user of a group. However, the authorities of the admin account cannot be specified at your will.
- Every user must belong to only one group. When selecting a group for a user, permissions of the user can only be a subset of group permissions and cannot exceed permission attributes of the group.
- Both the user name and group name support 1–31 characters and can only consist of letter, number, underline (\_), and hyphen (-).

## 5.9.1 Managing User

You can add, delete, or modify user, and set the authorities for the user of a group.

### Adding a user

**Step 1** Select **SETTING > Account > Account > User**.

The **User** interface is displayed. See Figure 5-68.

Figure 5-68 User

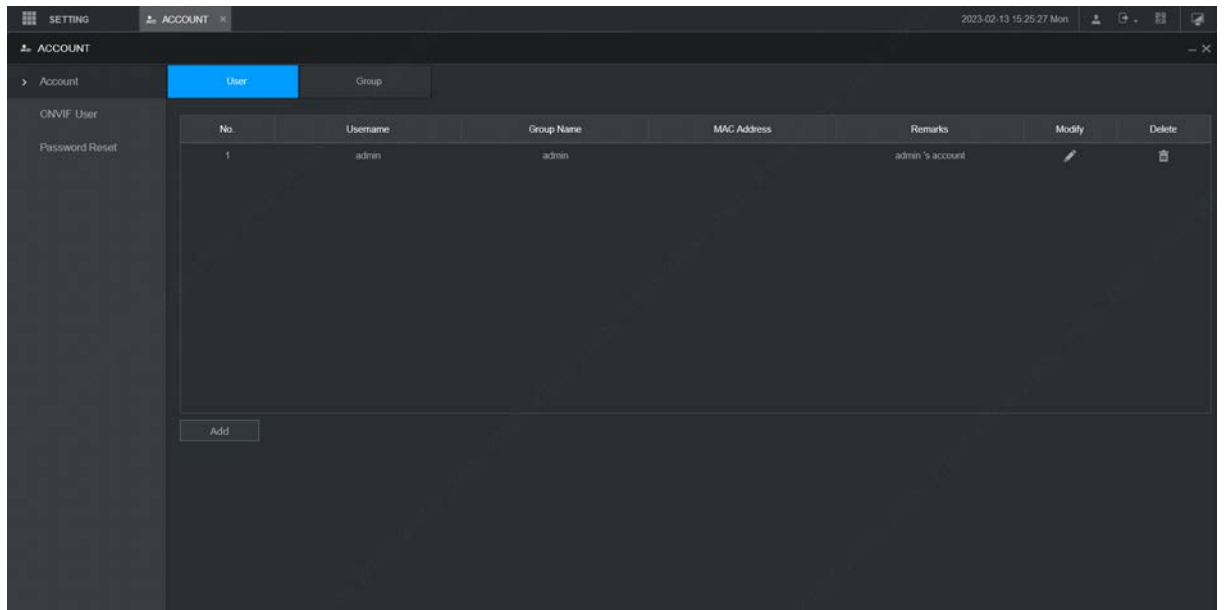

**Step 2** Click **Add**.

The **Add** interface is displayed. See Figure 5-69.

Figure 5-69 Add

**Step 3** Configure parameters. For details, see Table 5-26.

Table 5-26 Parameters description for adding user

Parameter	Description
User Name	Enter the user name and password, and confirm the password.
Password	
Confirm Password	
Group	Select the group that the users belong to.
User MAC	Enter user MAC address that is allowed to login the device.
Remarks	Enter a description of the user.
Period	Click <b>Setting</b> to set a valid period. The user is only allowed to log in to the device in the set period.

**Step 4** Click **System**, **Search**, or **Live** to set up user permissions.



- Select **All** to select all authorities in the category.
- The authorities of the admin account cannot be changed.

**Step 5** Click **OK**.



Click to modify user information; click to delete the user.

## Changing Password

**Step 1** On the **User** interface, click .

The **Modify** interface is displayed. See Figure 5-70.

Figure 5-70 Modify

The screenshot shows a 'Modify' dialog box with the following fields and options:

- Username: admin
- Group: admin
- Remarks: admin 's account
- User MAC: . . . . .
- Modify Password:
- Permission: System (selected), Search, Live
- System permissions (all checked): All, ACCOUNT, MANUAL CONTROL, NETWORK, BACKUP, SYSTEM, STORAGE, CAMERA, MAINTENANCE, SYSTEM INFO, EVENT, SECURITY
- Buttons: OK, Cancel

**Step 2** Select the **Modify Password** check box, and then enter old password, new password, and confirm password in the corresponding box.

**Step 3** Select the authority, including system, search, and live authorities.

**Step 4** Click **OK**.



- The new password can be set from 8 characters through 32 characters and contains at least two types from number, letter and special characters (excluding ' ' \ ; : & ). Please enter a strong password according to the password strength indication.
- A user authorized to manage user accounts can modify its own password and the passwords of other users.

## 5.9.2 Managing ONVIF User

When the remote device is connecting with the device through ONVIF protocol, please use the verified ONVIF account. Note System adopts three ONVIF user groups (admin, user and operator). You cannot add ONVIF user group manually.

### Adding a user

**Step 1** Select SETTING > Account > Account > ONVIF User.

The **ONVIF User** interface is displayed, see Figure 5-71.

Figure 5-71 ONVIF User

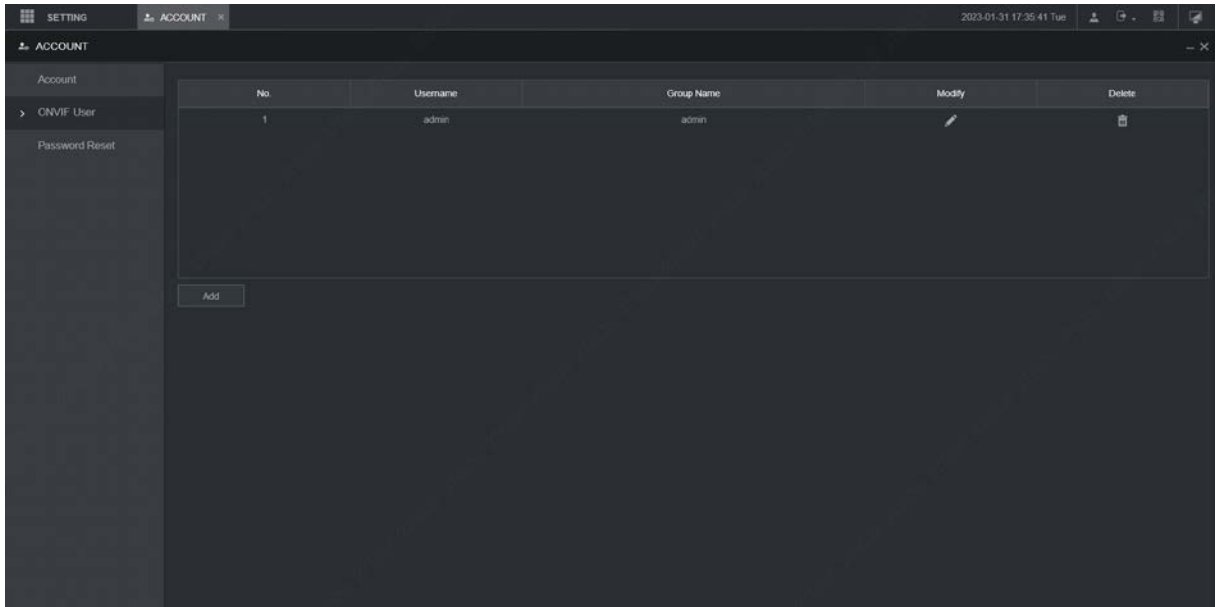

**Step 2** Click **Add**.

The **Add** interface is displayed. See Figure 5-72.

Figure 5-72 Add

A modal dialog box titled 'Add' with a close button (X) in the top right corner. It contains four input fields: 'Username' (text input), 'Password' (text input), 'Confirm Password' (text input), and 'Group' (dropdown menu). The 'Group' dropdown is currently set to 'admin'. At the bottom right, there are two buttons: 'OK' (highlighted in blue) and 'Cancel'.

**Step 3** Enter the user name and password, and confirm the password. Select the group that the users belong to.

**Step 4** Click **OK**.

## Changing Password

**Step 1** On the **ONVIF User** interface, click .

The **Modify** interface is displayed. See Figure 5-73.



Figure 5-73 Modify

Modify

Username: admin

Group: admin

Modify Password

Old Password: [ ]

New Password: [ ]

Confirm Password: [ ]

OK Cancel

**Step 2** Select the **Modify Password** check box, and then enter old password, new password, and confirm password in the corresponding box.

**Step 3** Click **OK**.

### 5.9.3 Managing Group

You can perform the operations to manage the group account, such as adding a group, deleting a group, and modifying a group.

**Step 1** Select SETTING > Account > Account > Group.

The **Group** interface is displayed, see Figure 5-74.

Figure 5-74 Group

ACCOUNT

> Account

User Group

No.	Group Name	Remarks	Modify	Delete
1	admin	administrator group		
2	user	user group		

Add

**Step 2** Click **Add**.

The **Add** interface is displayed. See Figure 5-75.

Figure 5-75 Add

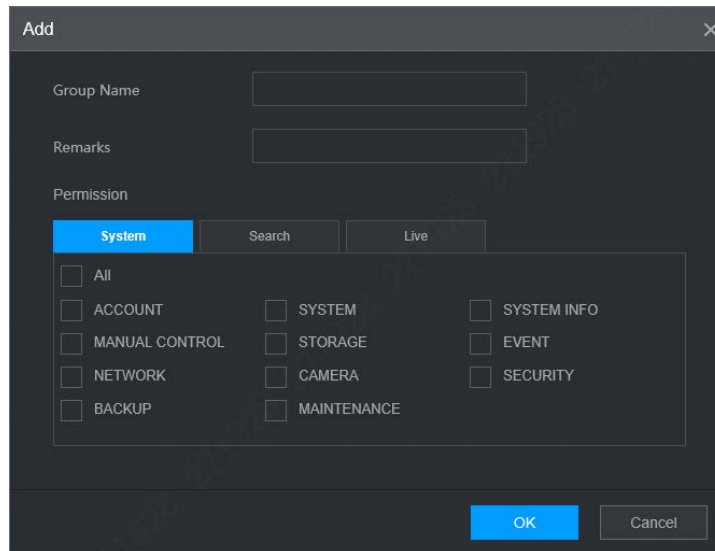

**Step 3** Set group name and remarks.

A group name consists of letters, numbers, and special characters (including "\_", "@", ";").



**Step 4** Select the authority, including system, search, and live authorities.



Select **All** to select all authorities in the category.

**Step 5** Click **OK**.



Click  to modify the corresponding group information; click  to delete the group.

## 5.9.4 Resetting Password

You can reset the password through the reserved phone number when you forget the login password of admin.

**Step 1** Open a browser and login the WEB interface of device.

The **Login** interface is displayed. See Figure 5-76.

Figure 5-76 Login

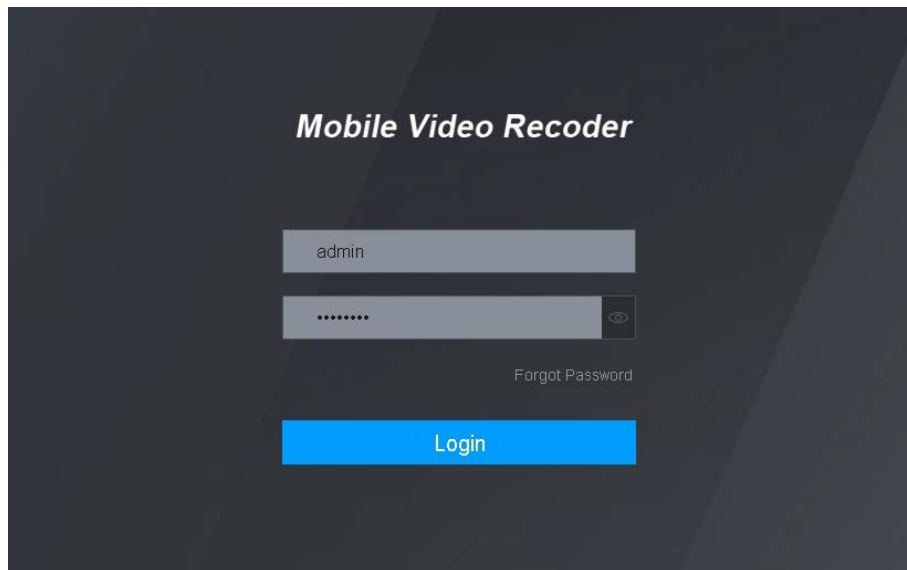

Step 2 Click **Forgot password?**

The **Password Reset** interface is displayed. See Figure 5-77

Figure 5-77 Password Reset (1)

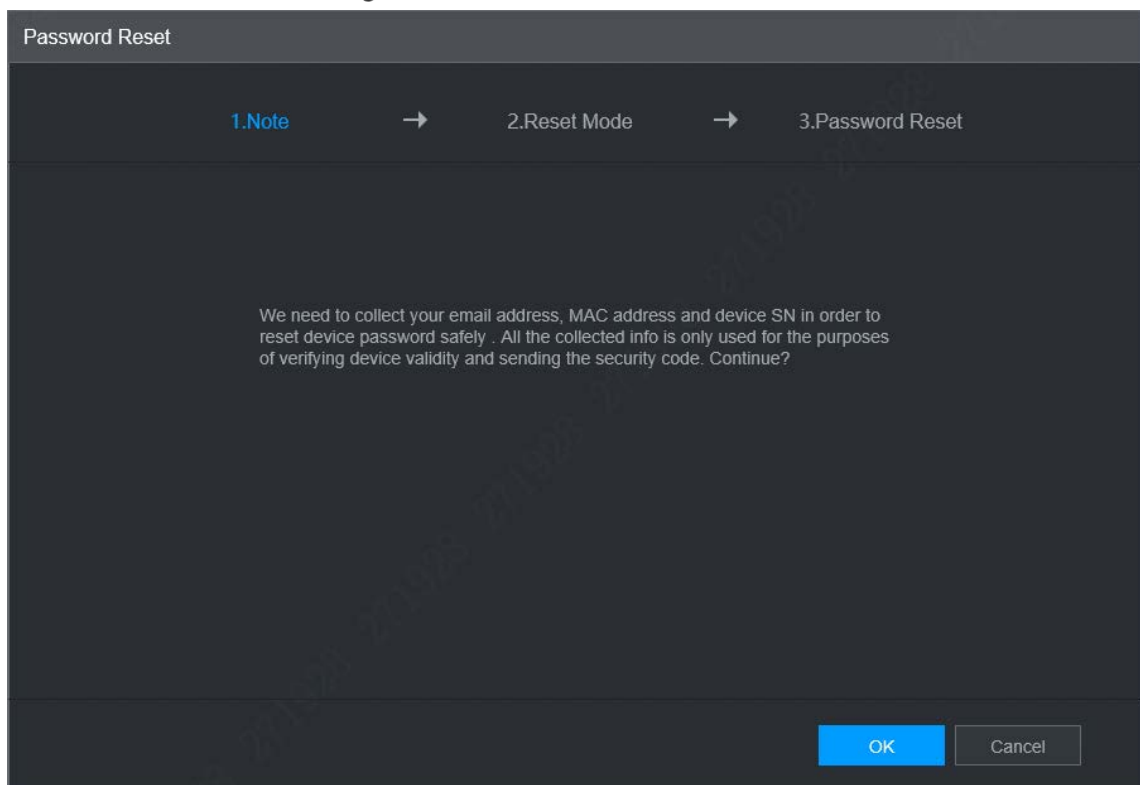

Step 3 Click **OK**.

The **Password Reset** is displayed. See Figure 5-78.

Figure 5-78 Password Reset (2)

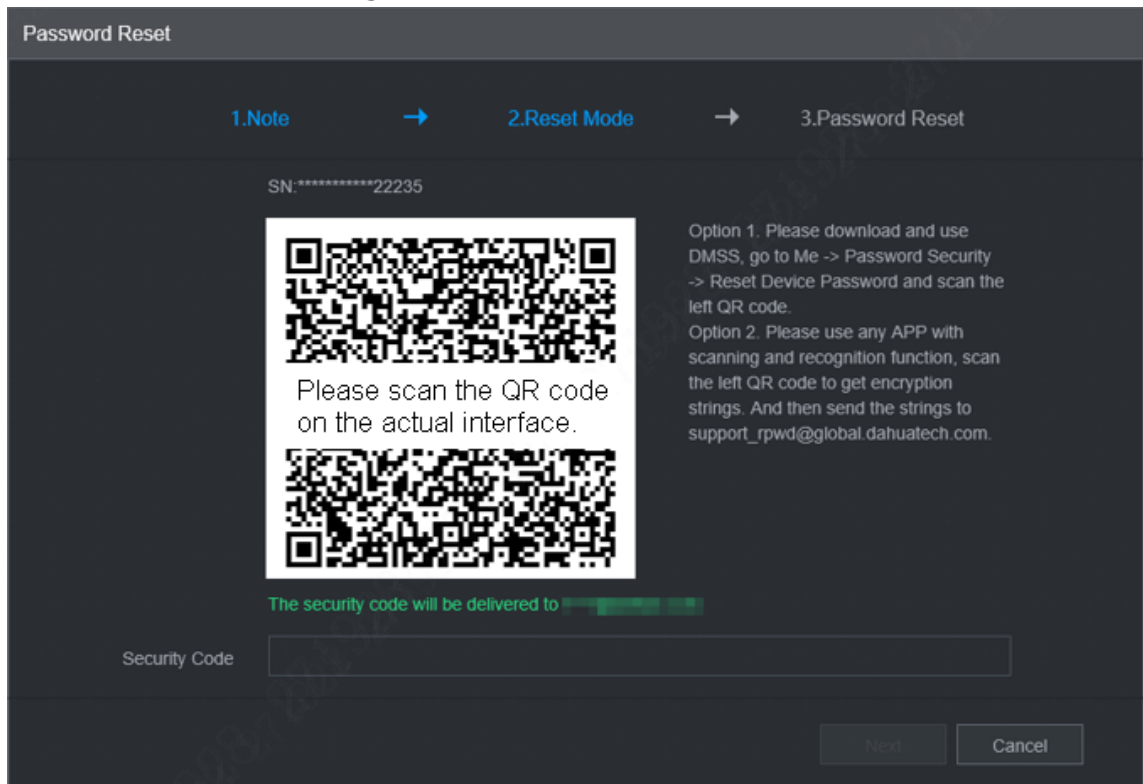

**Step 4** Follow the onscreen instructions to scan the QR code and get the security code.



- Please scan the QR code on the actual interface of device.
- At most two security codes will be generated by scanning the same QR code. To get more security code, refresh the QR code.
- Please use the security code within 24 hours after you receive it. Otherwise, it will become invalid.
- Wrong security code entered for up to five times will cause account locked for 5 min.

**Step 5** In the **Security Code** box, enter the security code received in your provided mailbox.

**Step 6** Click **Next**.

The new password setting interface is displayed. See Figure 5-79.

Figure 5-79 New password setting

Password Reset

1.Note → 2.Reset Mode → 3.Password Reset

Username admin

Password

Confirm Password

Password must be 8 to 32 characters, including at least two of the following categories: numbers, uppercase letters, lowercase letters and special characters (Characters like \"; ; & cannot be included in ).

OK

**Step 7** Reset and confirm the password.

The new password can be set from 8 through 32 non-empty characters and contains at least two types from number, letter and special characters (excluding "", "", ";", ":" and "&"). Please enter a strong password according to the password strength indication.

**Step 8** Click **OK**.

The system prompts successful operation and restarts. You can use the new password to log in to the device.

# 6 Update

## 6.1 System Version

You can view the device hardware characteristics, version such information.

Select **SETTING** > **System Info** > **Version**.

The **Version** interface is displayed. See Figure 6-1.

Figure 6-1 Version

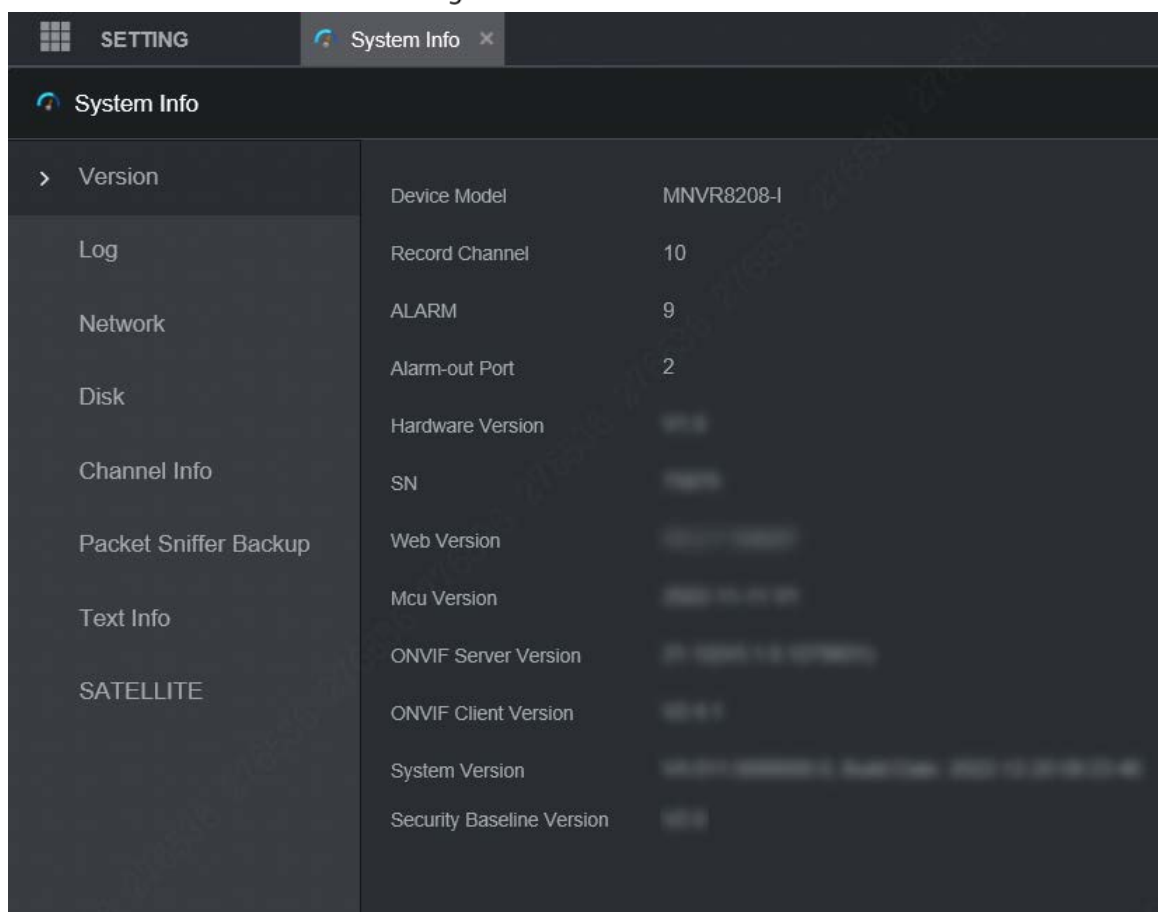

## 6.2 Update

Import the update file in the format of .bin to update the system.



- Do not disconnect the power or network, or restart or shut down the device during update cannot be used.
- Incorrect update programs may result in the device unable to work.

**Step 1** Select **SETTING** > **System** > **Update**.

The **Update** interface is displayed. See Figure 6-2.

Figure 6-2 Update

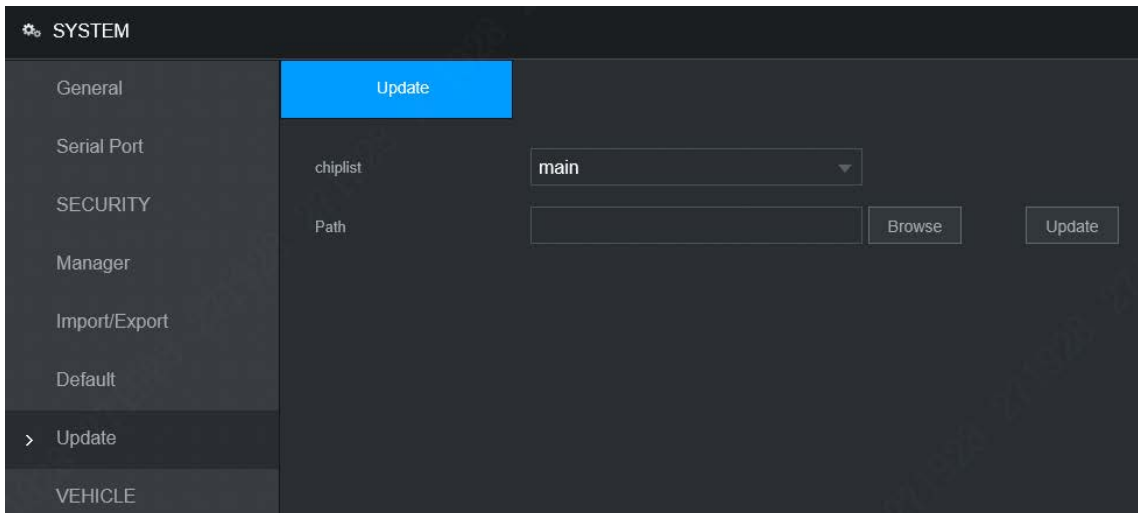

**Step 2** Select the chip list that suits your actual needs.

- To update system programs, select **Main** for the chip list.
- To update the MCU firmware programs, select **MCU** for the chip list.

**Step 3** Click **Browse** and select the update file you want to use.

**Step 4** Click **Update**.

The system starts updating. You should login to the WEB interface again after updating.

# 7 System Maintenance

## 7.1 Requirement for Maintenance

To keep the device running normally, it is recommended to manage, backup, and maintain the device.

- Check the monitoring screen of Device regularly.
- Delete the unused user and group regularly.
- Modify the user password every three months.
- View the system logs regularly and analyze the data to handle the abnormalities timely.
- Back up the system configurations regularly.
- Reboot this device regularly.
- Upgrade firm wares regularly.

## 7.2 System Information

You can view device version information, logs, network information, HDD information, channel information, satellite information, and MAC information.



For version information, see “6.1 System Version”.

### 7.2.1 Log

You can search, view, and back up the logs to local PC.

**Step 1** Select SETTING > System Info > Log.

The **Log** interface is displayed. See Figure 7-1.

Figure 7-1 Log

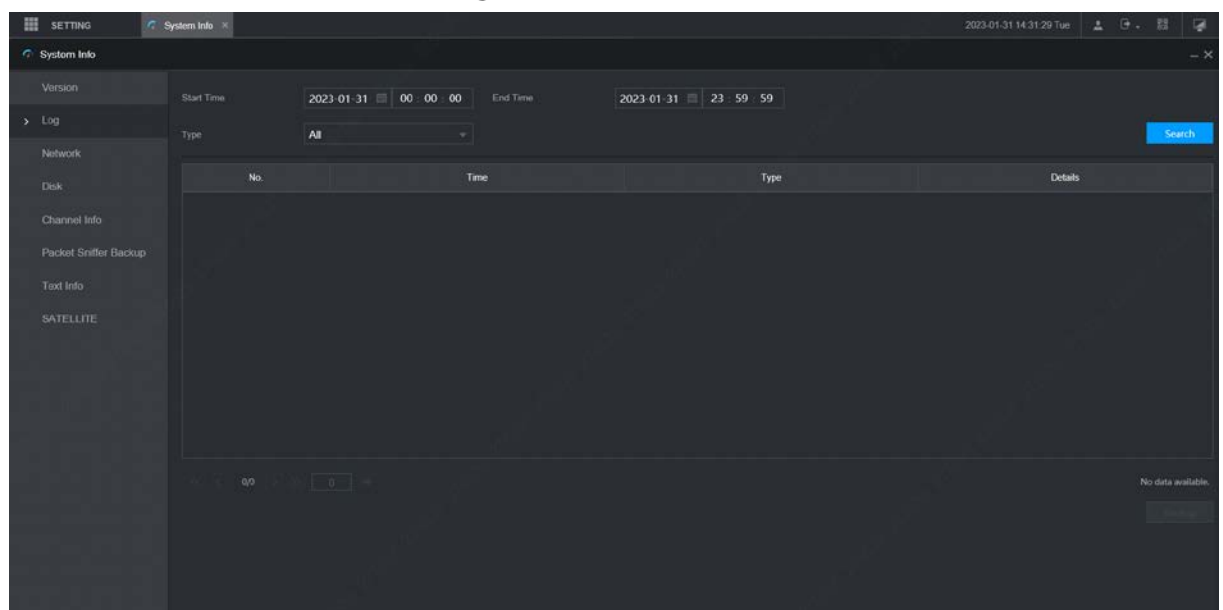



**Step 2** Set up Start Time, End Time, and Type.

**Step 3** Click **Search**.

The searched logs are displayed.



Select the log that you want to back up, and then click **Backup**. You can select the save path to save the log to PC.

## 7.2.2 Network Info

You can view IP information of the logged in device.

**Step 1** Select **SETTING > System Info > Network**. The **Network** interface is displayed. See Figure 7-2.

**Step 2** Click **Refresh** and the latest network information is displayed.

Figure 7-2 Network

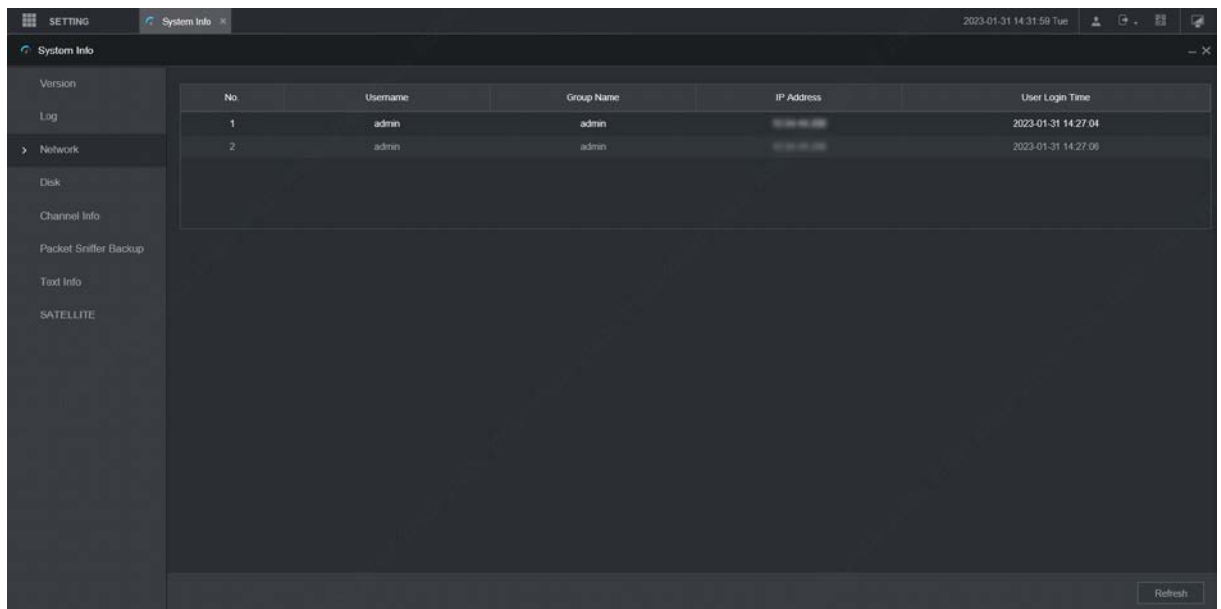

## 7.2.3 Disk

You can view the disk information of the device, including device name, physical position, health status, and free space.

Select **SETTING > System Info > Disk**. The **Disk** interface is displayed. See Figure 7-3.

Figure 7-3 Disk

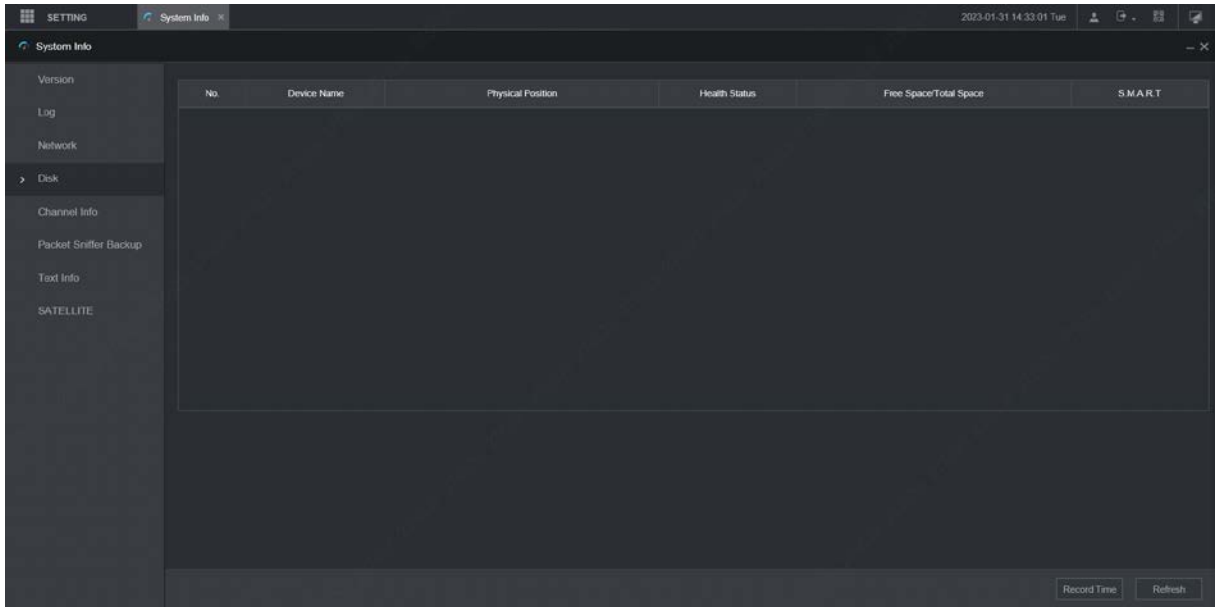

## 7.2.4 Channel Info

You can view the channel information.

Select **SETTING > System Info > Channel Info**. The **Channel Info** interface is displayed. See Figure 7-4.

Figure 7-4 Channel Info

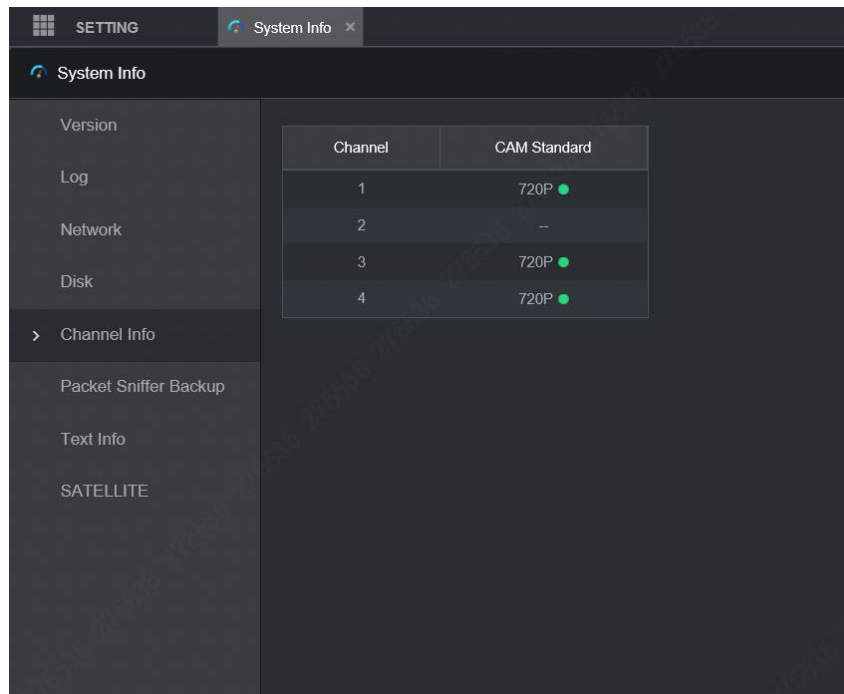

## 7.2.5 Satellite Info

You can view the satellite positioning information such as module status, positioning status, latitude and longitude, and search results.

Select **SETTING** > **System Info** > **Satellite**. The **Satellite** interface is displayed. See Figure 7-5.

Click **Refresh** and the latest satellite information is displayed.



- If the GPS module status indicates normal and does not position within five minutes, the GPS module automatically resets and re-positions. When the positioning information is obtained again, the GPS module reset times is up to 20, or the device is restarted, you can view the GPS module reset records in the log.
- When the GPS module is short-circuited for more than 10 seconds, the module status is abnormal and the GPS module is automatically powered off and no longer powered on. After the device is restarted, the GPS module will be powered on again.

Figure 7-5 Satellite

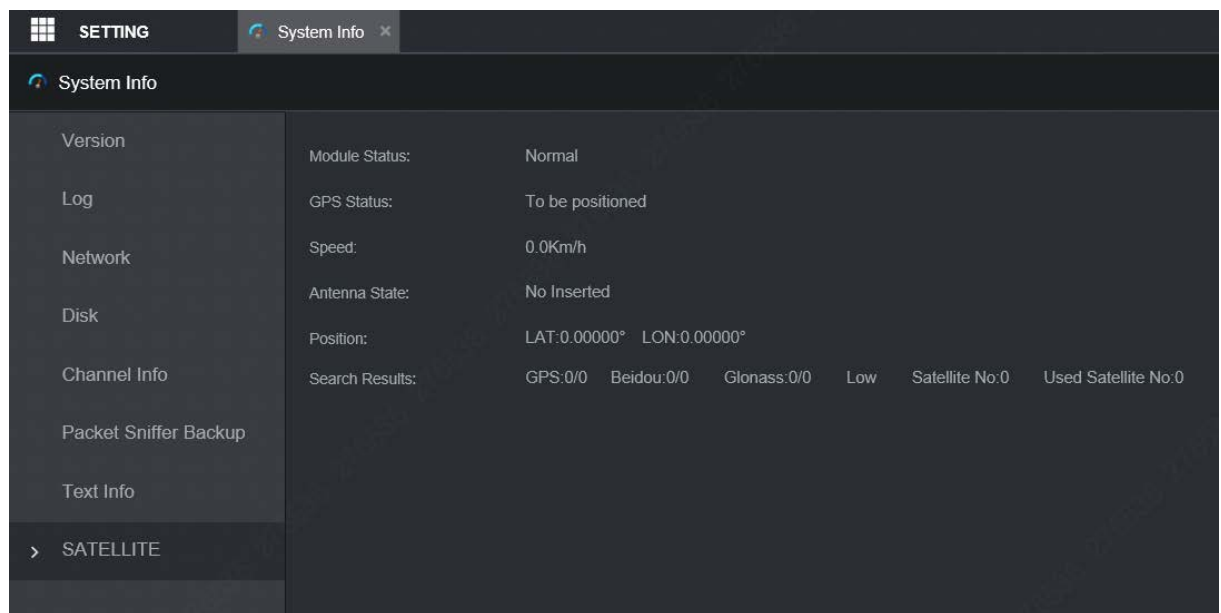

## 7.3 Automatic Maintenance

You can configure the automatic maintenance settings such as auto reboot, auto deleting old files, auto booting up, auto shutdown, and delay for auto shutdown.

### 7.3.1 Auto Reboot

Once the device is running for a long time, you can set to automatically reboot the device at idle time. After configuring auto reboot, when the device is working, it reboots according to the schedule.

**Step 1** Select **SETTING** > **System** > **Manager**.

The **Manager** interface is displayed. See Figure 7-6.

Figure 7-6 Manager

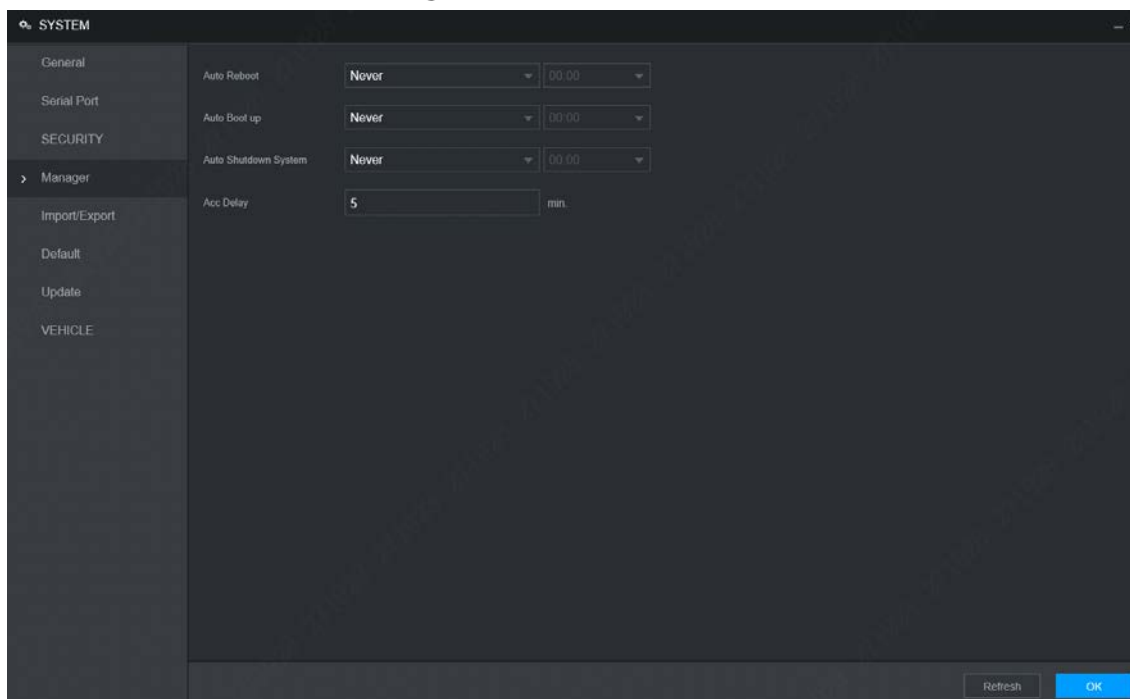

**Step 2** Select the strategy of auto restart.

- Select **Never**, and the device will never restart automatically.
- Select **Every Day**, set the device restart time, and the device will restart automatically at that time point.
- Select **Monday** to **Sunday**, set the device restart time, and the device will restart automatically at that time point every week. If **Sunday** and **01:00** are selected, the device will restart automatically at 1:00 every Sunday.

**Step 3** Click **OK**.

## 7.3.2 Auto Boot up

After configuring auto start, the device starts automatically at the scheduled time point. If you turn the vehicle key to ACC before the configured auto start time, the device starts immediately. When the documentation is powered off, the device will shut down as per the scheduled auto delay for shutdown.

**Step 1** Select SETTING > System > Manager.

The **Manager** interface is displayed.

**Step 2** Select the strategy of auto start.

- Select **Never**, and the device will never start automatically.
- Select **Every Day** and set the time. When you turn the vehicle key to ACC before this time point, the device starts immediately.

**Step 3** Click **OK**.

## 7.3.3 Auto Shutdown System

After configuring auto shutdown, the device automatically shuts down according to the ACC power off time and auto boot up setting.

- If you have set the time for auto start, there are two situations when the ACC is powered off: If the system time is between the auto start time and auto shutdown time, the device is turned off at the configured time point. If the system time is before the auto start time or after the auto shutdown time, the device is turned off immediately.
- If the auto booting up is not set, when the ACC is disconnected, the Device shuts down at the scheduled time.

Step 1 Select SETTING > System > Manager.

The **Manager** interface is displayed.

Step 2 Select the strategy of auto shutdown.

- Select **Never**, and the device will never shut down automatically.
- Select **Every Day** and set the time. The system will shut down as per the ACC power off time and auto start setting.
- Select **Every Day** for **Auto Shutdown**, and then enter the specific time.

Step 3 Click **OK**.

### 7.3.4 Acc Delay

After configuring delay for auto shutdown, when ACC is disconnected, the device shuts down as per the settings of delay for auto shutdown.

- If you enter a delay value that is not 0, the device automatically shuts down after the preset delay.
- If you enter 0, the device shuts down as per the auto shutdown settings without delay.

Step 1 Select SETTING > System > Manager.

The **Manager** interface is displayed.

Step 2 Configure the ACC delay for shutdown.

The value ranges from 0 through 65535. The fault value is 5.

Step 3 Click **OK**.

## 7.4 Backup and Restore

You can back up or restore the web configurations and restore to default settings.

### 7.4.1 Backing up Configurations

You can back up all the configurations of web.

Step 1 Select SETTING > System > Import/Export.

The **Import/Export** interface is displayed. See Figure 7-7.

Figure 7-7 Import/Export (1)

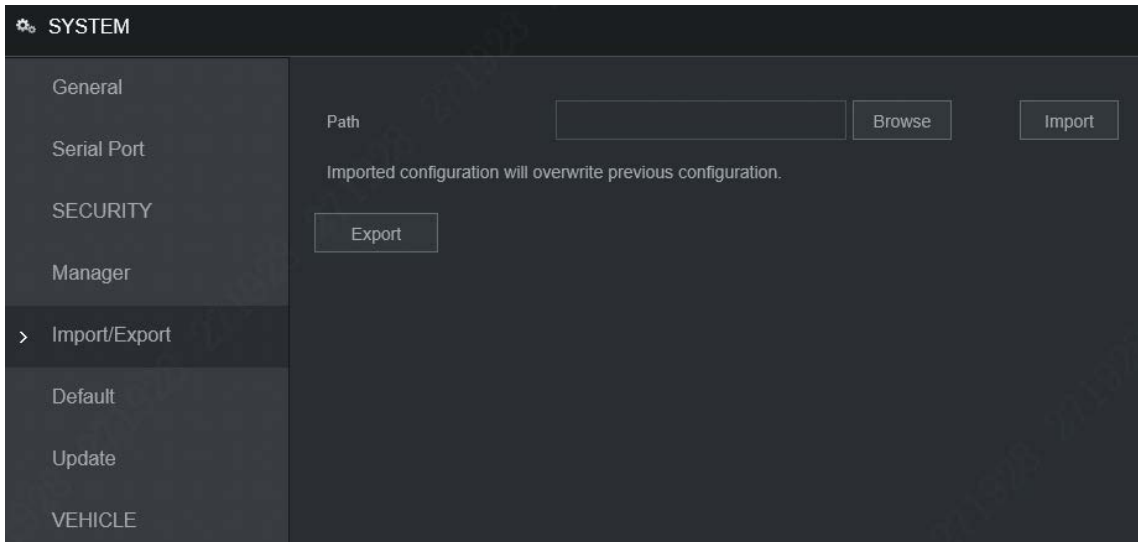

- Step 2** Click **Export**, and select the backup path.  
The system starts backing up configurations.

## 7.4.2 Importing Configurations

You can use the backed up configurations to quickly configure the device and restore the device configurations.

- Step 1** Select SETTING > System > Import/Export.  
The **Import/Export** interface is displayed. See Figure 7-8.

Figure 7-8 Import/Export (2)

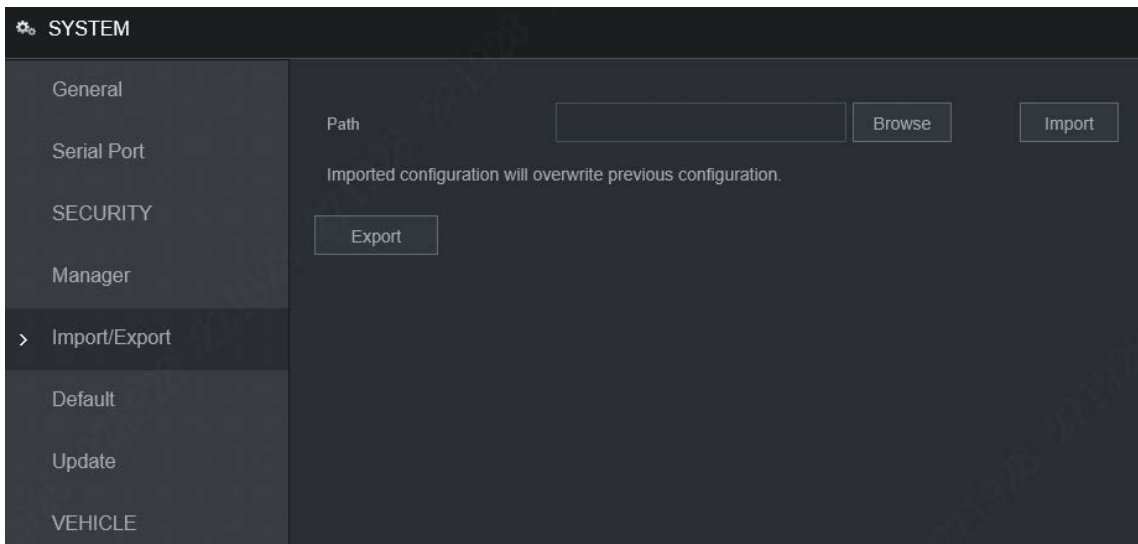

- Step 2** Click **Browse**, and then select the backup file you want to import.  
**Step 3** Click **Import**.  
The system pops up the reboot message. Click **OK**, the system starts importing the configurations and reboot the device after importing is completed.

## 7.4.3 Restoring to Default

You can restore the system to default configurations or the factory default. Only the user with the default & upgrade authorities can do this.



The corresponding functions will be restored to the factory settings, and your current configurations will be lost. Proceed with caution.

**Step 1** Select SETTING > System > Default.

The **Default** interface is displayed. See Figure 7-9.

Figure 7-9 Default

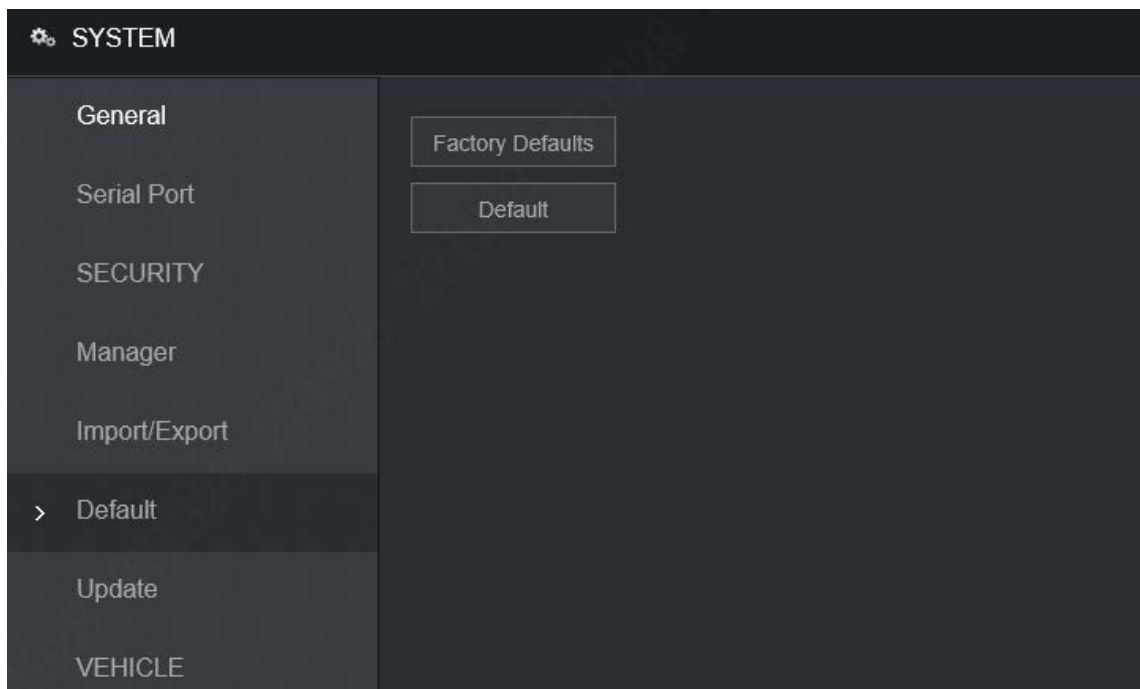

**Step 2** Select the check box of the options that you want to restore to the factory default.

- Default: Click **Default**, and the **Reboot** dialog box is popped up. See Figure 7-10. Then click **OK**. All configurations other than user name, password, security questions and device IP are restored to the default configuration of the device.
- Factory Default: Click **Factory Default**, and the **Reboot** dialog box is displayed. See Figure 7-11. Then click **OK**, and the system restarts. After the device is restarted, the system will restore to factory defaults, and the device requires initialization again. Proceed with caution.

When there is a user operating on the local interface, the factory default settings cannot be performed until the local user log out.

Figure 7-10 Reboot (1)

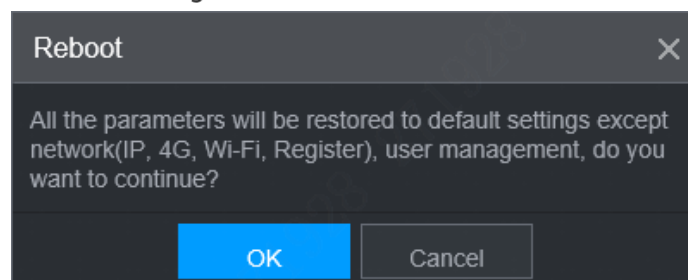
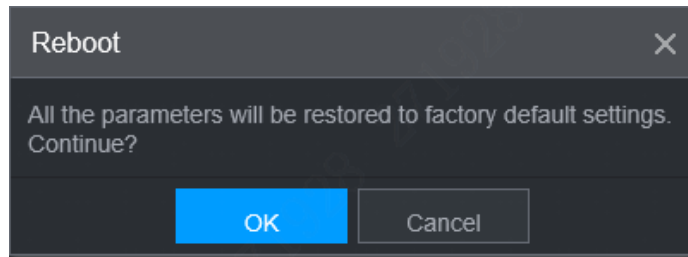

Figure 7-11 Reboot (2)



## 7.5 Network Sniffer

The packet data can be provided to the developers or engineers to analyze the network usage status.

### Prerequisites

The device being captured is connected to an external backup device.

### Procedure

**Step 1** Select **SETTING > Info > Packet Sniffer Backup**.

The **Packet Sniffer Backup** interface is displayed, see Figure 7-12.

Figure 7-12 Packet Sniffer Backup  
Packet Sniffer Backup

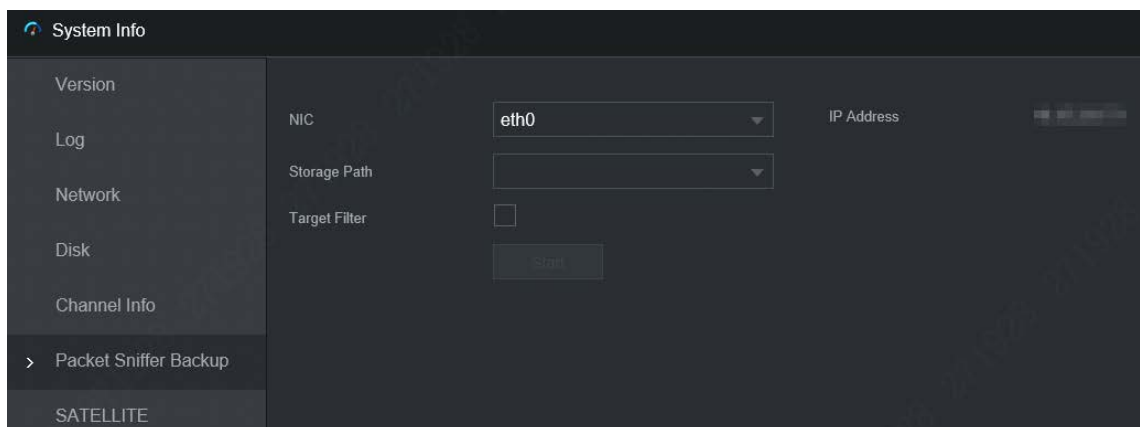

**Step 2** Select the Ethernet card and save path.

**Step 3** Select the **Target Filter** check box, and then enter the IP address that you want to filter.

**Step 4** Click **Start**.

The system starts the sniffer, and the data will be stored to the external backup device.

**Step 5** Click **Stop**.

The **Message** dialog box is displayed, see Figure 7-13.



Figure 7-13 Message

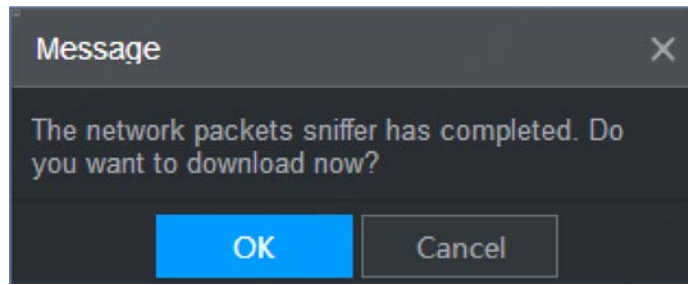

Step 6 Click **OK** or **Cancel** to complete the task.

- Click **OK** to download the files locally, which can be viewed in the storage path.
- Click **Cancel** to stop downloading.

## 8 Operating by DSS

Beside from web, you can also remotely log in to the Recorder from Digital Surveillance System (DSS). For details, see the manual of DSS.

# 9 FAQ

If your questions cannot be answer by the following contents, please contact your local service engineer or the service of our Headquarters for help. We can guide you to solve this problem.

**1) Q: Disconnect the constant electricity but the Recorder is still working.**

A: Possible causes:

- The default 5-minute shutdown delay is effective.
- The UPS setting provides constant power supply to the Recorder when the lithium battery voltage is above 7V.
- ACC is connected.

**2) Q: The Recorder gives squeal after it is boot up.**

A: Possible causes:

- Connecting to the display and being too close to the camera.
- A single channel interface or a large-image multi-channel interface. The first channel of sound comes from a local source.

**3) Q: The interface shows that no SIM card is detected.**

A: Possible causes:

- SIM card not inserted.
- Micro SIM card reversely inserted with its notch facing outward. Follow instructions on the label to insert the SIM card.
- SIM card is damaged.

**4) Q: DVR cannot boot up properly.**

A: Possible causes:

- The input power is not correct; the input voltage is too low or too high.
- Poor contact in the input power cable or incorrect wiring.
- HDD is damaged or poor contact between the HDD carrier and HDD.
- Main board is damaged.

**5) Q: DVR automatically reboots or frequently crashes.**

A: Possible causes:

- Input voltage is not stable or too low.
- The Recorder is not properly installed, which result in poor contact between components.
- Poor heat dissipation and too many dusts result in poor working environment for the Recorder.
- Hardware malfunction.

**6) Q: HDD cannot be detected after rebooting.**

A: Possible causes:

- HDD not installed.
- Poor contact between the HDD carrier and HDD.
- HDD is damaged.

**7) Q: Blank screen in a channel of the display**

A: Possible causes:

- A camera is damaged. Replace the damaged camera.
- The connection wire is damaged. Replace the damaged connection wire.

**8) Q: No video output from single-channel, multiple-channel or all-channel.**

A: Possible causes:

- Program is not compatible. Please upgrade to the correct version.
- Brightness value of all channel is 0. Please restore to default setting.
- No video input signal or the signal is too weak.
- Channel protection or screen protection is configured.
- Hardware malfunction.

**9) Q: Real-time video image is abnormal, such as color and brightness is distorted.**

A: Possible causes:

- NTSC and PAL settings are not correct, and the image becomes black and white.
- Recorder and monitor resistance is not compatible.
- Video network transmission distance is too far or transmission line signal attenuation is too much.
- NVR color or brightness settings are not correct.

**10) Q: No recorded video can be found in local playback.**

A: Possible causes:

- Poor contact between the HDD carrier and HDD.
- HDD is damaged.
- Upgraded program is not compatible.
- The recording file that you want to search has been overlapped.
- The recorded file is not opened.

**11) Q: Video is distorted in local search.**

A: Possible causes:

- Video quality setting is too low.
- Program read error, bit data is too small, and there is full of mosaic in the screen.  
Please firstly try to restart the DVR to solve this problem.
- Disk error
- Hardware malfunction.

**12) Q: The monitor has no sound.**

A: Possible causes:

- It is not an active speaker.
- Audio cable is damaged.
- Hardware malfunction.

**13) Q: There is audio under monitoring state but no audio under playback state.**

A: Possible causes:

- Audio function is not enabled.
- The corresponding channel does not connect to the camera. Playback is not continuous when the screen is blue.

**14) Q: System time is not correct.**

A: Possible causes:

- Setting is not correct.
- Poor battery contact or voltage is too low.
- Crystal oscillator is poor.

**15) Q: USB backup error.**

A: Possible causes:

- Too much data which occupies CPU resources. Please stop recording first and then begin backup.
- Backup Recorder is not compatible.
- Backup Recorder is damaged.
- The backup Recorder features high power and needs separate power supply.

**16) Q: Alarm function does not work.**

A: Possible causes:

- Alarm setting is not correct.
- Alarm cable connection is not correct.
- Alarm input signal is not correct.
- There are two loops connected to one alarm Recorder.

**17) Q: Messy channel display.**

A: Possible causes:

- Incorrect selection of camera type. Auto switch is recommended.
- The camera is damaged.

**18) Q: Record storage time is not enough.**

A: Possible causes:

- Low camera quality, dirty lens, camera installed against the light, or iris not properly adjusted caused large bit rate.
- HDD capacity is not enough.
- The HDD is damaged.

**19) Q: No 3G/4G dial-up. No dial-up IP,**

A: Possible causes:

- Check if the SIM card is normal.
- Check if the SIM card is not in service.
- Check if the 3G/4G antenna is connected as intended.
- Check if the 3G/4G signals are strong enough.
- Try out with another SIM card.

**20) Q: 3G/4G platform is not online.**

A: Possible causes:

- Check if 3G/4G dial-up is normal.
- Check if local active registration is correctly set up.
- Check if the sever terminal is correctly set up.

**21) Q: No GPS data.**

A: Possible causes:

- Check if the GPS antenna is connected as intended.
- Make sure the GPS antenna is in a place where signals are not blocked.

**22) Q: GPS drifting and produces speed for no reason.**

A: Possible causes:











Weak GPS signal.

# Appendix 1 Mouse Operations



The operations are based on the considerations for right-handed users.

Beside the operations from the front panel and remote control, you can also use mouse to operate menus. Insert the mouse to the USB port of the Recorder.

Operation	Function
Click the left mouse button	If the user has not logged into the system, the password box is displayed first. During real-time monitoring, click the left mouse button to go to the main menu.
	When you have selected one menu item, click it to view menu content.
	Implement the operations indicated on the control.
	Change the status of the check box.
	Click the combo box, the drop-down list is displayed.
	<p>In text box, click the corresponding button on the panel to enter a numeral, punctuation, English character (small/capitalized), or Chinese. Left-click the symbol on the panel to complete value input;  represents backspace, and  represents space.</p> <p>In English input mode: Click  to enter a space, and click  to delete the previous character.</p> <div style="display: flex; justify-content: space-around; align-items: center;">   </div> <p>In numeral input mode: Click  to delete all numbers, and click  to delete the previous number.</p>  <p>In special characters input mode: For the numbers and characters on the soft panel, press the numbers on the front panel to enter the corresponding characters, for example, press 1 means entering /. You can also directly use the mouse to click to enter the characters.</p> 
Double-click the left mouse button	<p>The special operation to perform a specific action. For example, double-click the recorded video file to start playback.</p> <p>In multi-image, double-click a channel image to display it in full screen. Double-click again to restore the previous multi-window screen.</p>

Right-click	In the real-time monitoring screen, right-click on the screen, the shortcut menu is displayed. You can configure the settings including multi-image mode (related to the number of channels of the Recorder), PTZ control, color setting, recording search, recording control, alarm output, and main menu. To use PTZ control and color setting apply to the images corresponding to the pointer. If it was multi-image mode before settings, the system auto switches to the single images of corresponding channels first.
	Do not save the setting and exit the current menu.
Wheel button	In numeral input box, rotate the wheel button to increase or decrease the numeral value.
	Switch between items in the combo box.
	Page up or page down.
Move	Select and move a control of the current coordinates or one of its items.
Drag	Box select an area and set up area overlap.



## Appendix 2 HDD Capacity Calculation

In the first installation of the HDD, check whether the HDD is already installed. To install IDE HDD, pay attention to the jumper of the HDD.

HDD capacity calculation formula:

Total capacity (M) = Channel number × Demand time length (hour) × HDD capacity occupied per hour (M/hour)

Recording time calculation formula:

Recording time (hour) = 
$$\frac{\text{HDD total capacity (M)}}{\text{HDD capacity occupied per hour (M/hour)} \times \text{Channel number}}$$

The Recorder adopts MPEG4/H.264 compression technology, which features a large dynamic range. Therefore, when calculating HDD capacity, you should accord to the bit rate to evaluate the file size generated per hour from each channel.

# Appendix 3 Cybersecurity Recommendations

Cybersecurity is more than just a buzzword: it's something that pertains to every device that is connected to the internet. IP video surveillance is not immune to cyber risks, but taking basic steps toward protecting and strengthening networks and networked appliances will make them less susceptible to attacks. Below are some tips and recommendations on how to create a more secured security system.

## **Mandatory actions to be taken for basic equipment network security:**

### **1. Use Strong Passwords**

Please refer to the following suggestions to set passwords:

- The length should not be less than 8 characters;
- Include at least two types of characters; character types include upper and lower case letters, numbers and symbols;
- Do not contain the account name or the account name in reverse order;
- Do not use continuous characters, such as 123, abc, etc.;
- Do not use overlapped characters, such as 111, aaa, etc.;

### **2. Update Firmware and Client Software in Time**

- According to the standard procedure in Tech-industry, we recommend to keep your equipment (such as NVR, DVR, IP camera, etc.) firmware up-to-date to ensure the system is equipped with the latest security patches and fixes. When the equipment is connected to the public network, it is recommended to enable the "auto-check for updates" function to obtain timely information of firmware updates released by the manufacturer.
- We suggest that you download and use the latest version of client software.

## **"Nice to have" recommendations to improve your equipment network security:**

### **1. Physical Protection**

We suggest that you perform physical protection to equipment, especially storage devices. For example, place the equipment in a special computer room and cabinet, and implement well-done access control permission and key management to prevent unauthorized personnel from carrying out physical contacts such as damaging hardware, unauthorized connection of removable equipment (such as USB flash disk, serial port), etc.

### **2. Change Passwords Regularly**

We suggest that you change passwords regularly to reduce the risk of being guessed or cracked.

### **3. Set and Update Passwords Reset Information Timely**

The equipment supports password reset function. Please set up related information for password reset in time, including the end user's mailbox and password protection questions. If the information changes, please modify it in time. When setting password protection questions, it is suggested not to use those that can be easily guessed.

### **4. Enable Account Lock**

The account lock feature is enabled by default, and we recommend you to keep it on to guarantee the account security. If an attacker attempts to log in with the wrong password several times, the corresponding account and the source IP address will be locked.

### **5. Change Default HTTP and Other Service Ports**

We suggest you to change default HTTP and other service ports into any set of numbers between 1024~65535, reducing the risk of outsiders being able to guess which ports you are

using.

#### **6. Enable HTTPS**

We suggest you to enable HTTPS, so that you visit Web service through a secure communication channel.

#### **7. Enable Allowlist**

We suggest you to enable allowlist function to prevent everyone, except those with specified IP addresses, from accessing the system. Therefore, please be sure to add your computer's IP address and the accompanying equipment's IP address to the allowlist.

#### **8. MAC Address Binding**

We recommend you to bind the IP and MAC address of the gateway to the equipment, thus reducing the risk of ARP spoofing.

#### **9. Assign Accounts and Privileges Reasonably**

According to business and management requirements, reasonably add users and assign a minimum set of permissions to them.

#### **10. Disable Unnecessary Services and Choose Secure Modes**

If not needed, it is recommended to turn off some services such as SNMP, SMTP, UPnP, etc., to reduce risks.

If necessary, it is highly recommended that you use safe modes, including but not limited to the following services:

- SNMP: Choose SNMP v3, and set up strong encryption passwords and authentication passwords.
- SMTP: Choose TLS to access mailbox server.
- FTP: Choose SFTP, and set up strong passwords.
- AP hotspot: Choose WPA2-PSK encryption mode, and set up strong passwords.

#### **11. Audio and Video Encrypted Transmission**

If your audio and video data contents are very important or sensitive, we recommend that you use encrypted transmission function, to reduce the risk of audio and video data being stolen during transmission.

Reminder: encrypted transmission will cause some loss in transmission efficiency.

#### **12. Secure Auditing**

- Check online users: we suggest that you check online users regularly to see if the device is logged in without authorization.
- Check equipment log: By viewing the logs, you can know the IP addresses that were used to log in to your devices and their key operations.

#### **13. Network Log**

Due to the limited storage capacity of the equipment, the stored log is limited. If you need to save the log for a long time, it is recommended that you enable the network log function to ensure that the critical logs are synchronized to the network log server for tracing.

#### **14. Construct a Safe Network Environment**

In order to better ensure the safety of equipment and reduce potential cyber risks, we recommend:

- Disable the port mapping function of the router to avoid direct access to the intranet devices from external network.
- The network should be partitioned and isolated according to the actual network needs. If there are no communication requirements between two sub networks, it is suggested to use VLAN, network GAP and other technologies to partition the network, so as to achieve the network isolation effect.

- Establish the 802.1x access authentication system to reduce the risk of unauthorized access to private networks.
- It is recommended that you enable your device's firewall or blocklist and allowlist feature to reduce the risk that your device might be attacked.