



MEET ME mobile application

FERMAX



INSTALLATION AND SETUP MANUAL

MEET ME MEET APPLICATION for MOBILE.

Code 970139Ic V04_22

This technical document has been edited by FERMAX ELECTRÓNICA for informational purposes, and the company reserves the right to modify any of the technical specifications of the products referred to herein at any time without prior notice. These changes shall be reflected in later editions of the same document.

ÍNDICE

	1. INTRODUCTION	4
	2. INSTALLATION	4
	2.1 INSTALLATION STEPS	4
	STEP 1: Monitor label and Panel label	4
	STEP 2: PANEL & GUARD UNIT web server configuration	5
	a) Select the NETWORK CONFIGURATION option	5
	b) Select the GENERAL option	5
	c) Select the SIP option	6
	STEP 3: MONITOR web server configuration	6
	a) Select the NETWORK CONFIGURATION option	7
	b) Select the ADVANCED option	7
	STEP 4: Downloading and installing the APP	7
	3. USING THE APP	10
	3.1 ICON GLOSSARY	11
	3.2 CALL MANAGEMENT	12
	3.2.1 GENERAL	12
	a) INCOMING CALLS	12
	b) MISSED CALLS	12
	3.2.2 RESPONDING TO A CALL IN iOS WITH MEET ME V1.3	13
	a) With telephone LOCKED	13
	b) With telephone UNLOCKED	14
	3.3 AUTO SWITCH-ON (OUTGOING CALLS)	15
	a) From your contact list	15
	3.4 CALL LOG	16
	3.5 CONTACT LIST	18
	3.6 CALL DETAILS	19
	3.7 APLICATION SETTINGS	19

1. INTRODUCTION

The MEET ME APP is the app that allows you receive calls from MEET panels & guard units whenever there is a monitor installed in the house and at least one panel in the installation. The MEET installation must be connected to the Internet.

It's a free APP from Google Play or Apple Store. Check availability of the APP in your area. Requires mobile phone compatible with Android version 8 or higher and Apple version 13 or higher.

The USERNAME and PASSWORD details are found on a label on each MEET monitor.

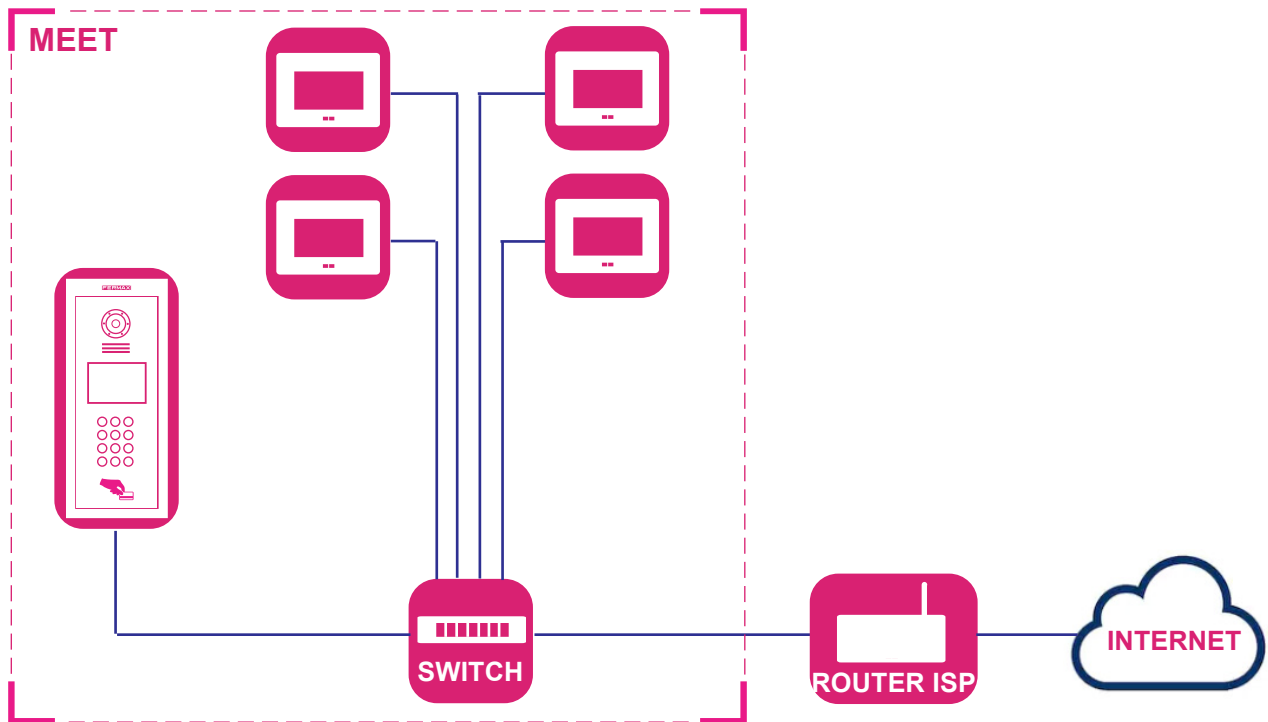

2. INSTALLATION

Installation requirements:

- Verify that the MEET system is installed correctly and makes calls normally.

PRECAUTIONS: It is necessary to verify the following in the installation:

- Confirm that the router does not have the SIP ALG option and if it does, it is deactivated.
 - - The operator must not filter SIP packets to port 5060.
 - - The router or operator firewall must not block the Meet devices communication.
 - There are no other SIP servers or SIP-based services in the installation.
 - The upload bandwidth must be at least 3Mb per telephone panel communication.
 - MEET devices are upgraded to version 2.0 or higher.
 - The MEET device and ROUTER must be on the same network (IP ranges).
- The free user account required by the APP is included on the monitors via a label. This will allow the APP to be connect with the monitor.
- On the monitor we will add the account indicated on the label as an **extension**, where the call will be diverted.

2.1 INSTALLATION STEPS

STEP 1: Monitor label and Panel label.

Find the MEET label on the monitor and the MEET label on the panel.

<p><i>For example MONITOR label:</i> Username: 0000018 Password: ABC123GH</p>	 Username: 0000018 Password: ABC123GH meet.fermax.com	<p><i>For example PANEL label:</i> Username: 0065478 Password: CNM8HI2V</p>	 Username: 0065478 Password: CNM8HI2V meet.fermax.com
---	--	---	--

STEP 2: PANEL & Guard Unit web server configuration.

- Correctly configure the call divert server in the cloud properly on each of the panels.
- Find the label on the plate with the user account on it.
- Connect to the panel's web server.

As the MEET installation must be connected to the Internet in order to have call forwarding to the mobile phone, there are some options within the screens: GENERAL and NETWORK SETTINGS, which must be set up for proper operation.

The rest of the options on these screens must already be set up and have the values that were programmed when the MEET installation was first carried out. [See manuals corresponding to the MEET system on the web.](#)

a) Select the NETWORK CONFIGURATION option.

Remember that in the NETWORK CONFIGURATION screen of the panel, in the GATEWAY option, there must be the IP of the router that has Internet access.

All other options on this screen must have the values that were programmed when the MEET installation was first carried out. [See manuals for the system on the web.](#)

- Click and select NETWORK CONFIGURATION and set the following parameters:
 - GATEWAY: **IP address of the router that has Internet access.**
 - DNS: **DNS on the panel.** By default: 8.8.8.8

- Press **SAVE**

b) Select the GENERAL option.

- Click and select GENERAL and set the following parameter:
 - SIP CALL DIVERT MODE: Select **PARALLEL**

- Press **SAVE**

c) Select the SIP option.

- Click and select SIP and set the following parameters:
 - SIP SERVER: **sip:sip.fermax.com**
 - DOMAIN: **sip.fermax.com**
 - STUN IP: **0**. (This value can be automatically updated).
 - STUN PORT: **5060**
 - H.264: **102**
 - SIP USER: **Username on the panel label.**
 - PASS SIP: **Password from the panel label.**
- Press **SAVE**

DEVICE	SIP SETTINGS	
GENERAL	ENABLE SIP:	<input checked="" type="checkbox"/>
NETWORK	SIP SERVER:	sip:sip.fermax.com
ACCESS	DOMAIN:	sip.fermax.com
FACE RECOG.	OUTBOUND:	sip:
IP CAMERA	STUN IP:	sip.fermax.com
SIP	STUN PORT:	0
SIP TRUNK	H.264:	102
SIP CALL	SIP USER:	0065478
ADVANCED	SIP PASS:
PINCODE	CONVERSATION:	120s
	RING TIME:	35s
	<input type="button" value="SAVE"/>	

*Example:
 Username: 0065478
 Password: CNM8HI2V*

Important note: This screen corresponds to a building outdoor panel. 1 Line panel will have its corresponding screen.

STEP 3: MONITOR web server configuration.

- Correctly configure the call forwarding server in the cloud properly on the home monitor. If there is more than one monitor in the house, it would be only programmed on the main one (MONITOR: 0). This setup is in the GENERAL option. [View screen 1](#).
- Find the monitor label with the account to be used by the monitor.
- Connect to the monitor's web server.

1

DEVICE	GENERAL SETTINGS	
GENERAL	BLOCK:	
NETWORK	APARTMENT:	
IP CAMERA	MONITOR:	0
SIP	SYNC CODE:	
ADVANCED	<input type="button" value="SAVE"/>	
RELAY CONTROL		
VERIFICATION		
PINCODE		

Pre-programmed options

↑
Indicates that this is the main Monitor

As the MEET installation must be connected to the Internet in order to have call divert to the mobile phone, there are some options within "NETWORK CONFIG." that must be set up to for it to work properly. The rest of the options on this screen must already be set up and have the values that were programmed when the MEET installation was first carried out. [See manuals corresponding to the MEET system on the web.](#)

a) Select the NETWORK CONFIGURATION option.

- Click and select NETWORK CONFIGURATION and set the following parameters:
 - GATEWAY: **IP address of the router that has Internet access.**
 - DNS: **DNS on the panel.** By default: 8.8.8.8
- Press **SAVE**

b) Select the ADVANCED option.

- Click and select ADVANCED and set the following parameters
 - In the **SIP EXT** field select **1**.
 - In the **URL** field, enter the USERNAME (0000018) indicated on the monitor label, adding the text indicated on the screen: **sip:0000018@sip.fermax.com**
 - Press **SAVE**.

Example:
Monitor label



STEP 2: Downloading and installing the APP.

1. In Google Play or Apple Store, search and download FERMAX MEET ME. The USERNAME and PASSWORD can be found in a sticker in each MEET monitor.

Important notes:

- The application can be operated without granting contact permission:
 - * If this permission is not granted, the user will not be able to create SIP contacts in the MEET ME APP and store them in the phone book. You will not be able to list e.g. the plate contact to perform an AutoStart.
 - * To perform Auto Power Up the user should know and dial the SIP account number of the board, for example 0065478 and press the call icon. See chapter 3.3 Auto switch-on.

For example PANEL label:
Username: 0065478
Password: CNM8HI2V



- In iOS, the user is asked for camera permission by default. Failure to grant this permission does not prevent the proper functioning of the MEET ME PPP.

Permissions requested by Android

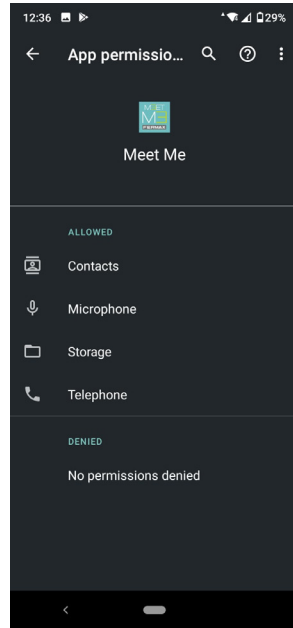

Permissions requested by iOS

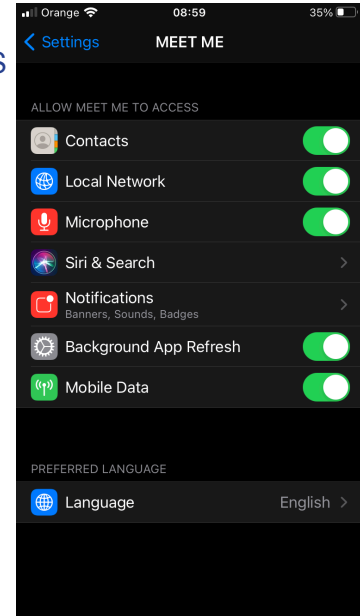

2 Run the application and enter the assigned account in all smartphones in the same house.



Example:
Username: 0000018

Password: ABC123GH

Accept the terms and conditions of use to be able to START SESIÓN.

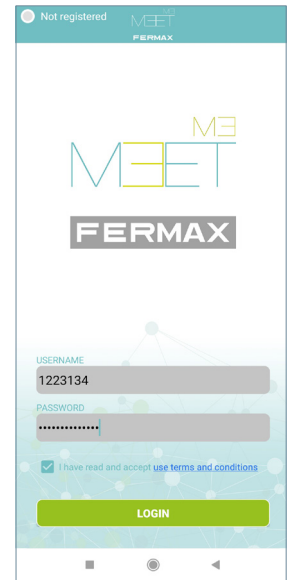

3. A prompt is displayed in the upper left corner indicating that the system is registered.

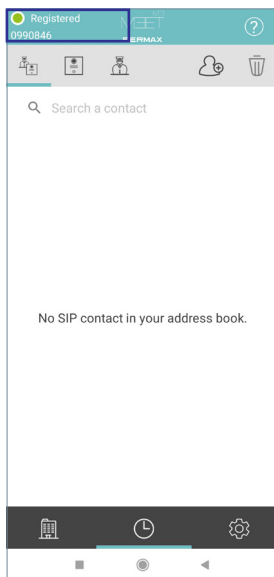

Pressing  displays the SETUP screen.

You must **activate the AUXILIARY RELAY** if the installer has connected it, in order to have the possibility of opening a second access. Consult the installer.

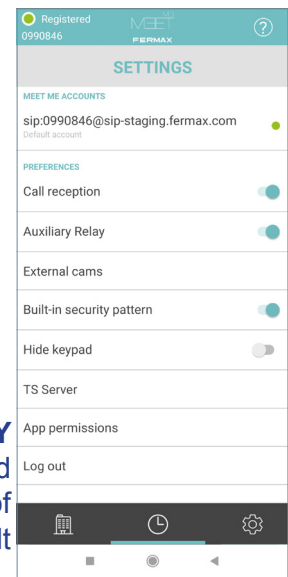

From this same menu you can also activate the external cameras option if they exist in the installation.

Call reception / Auto-on

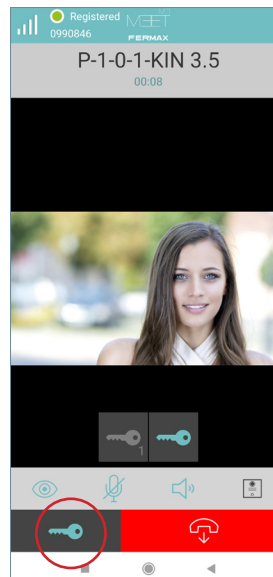

On the RECEIVE CALL and AUTO POWER ON screens, when the opening option is pressed, the possible openings will be displayed.

Opening second access (1)

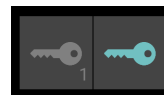

IP Camera switch



Note: These options are activated from the app settings, see chapter 3.7 APPLICATION SETTINGS.

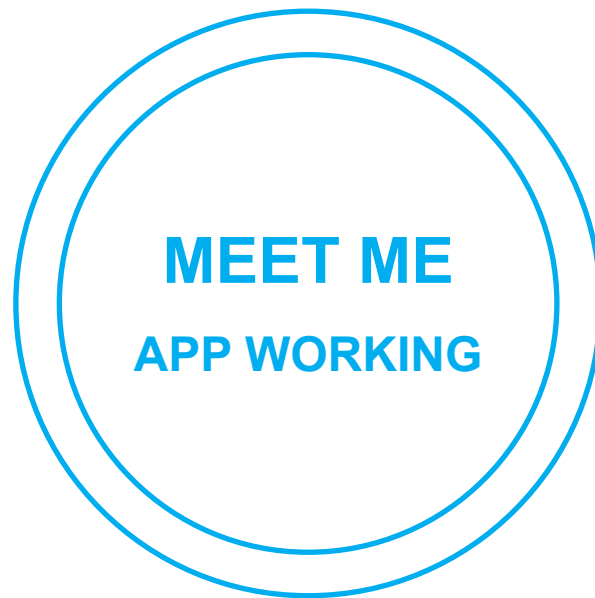





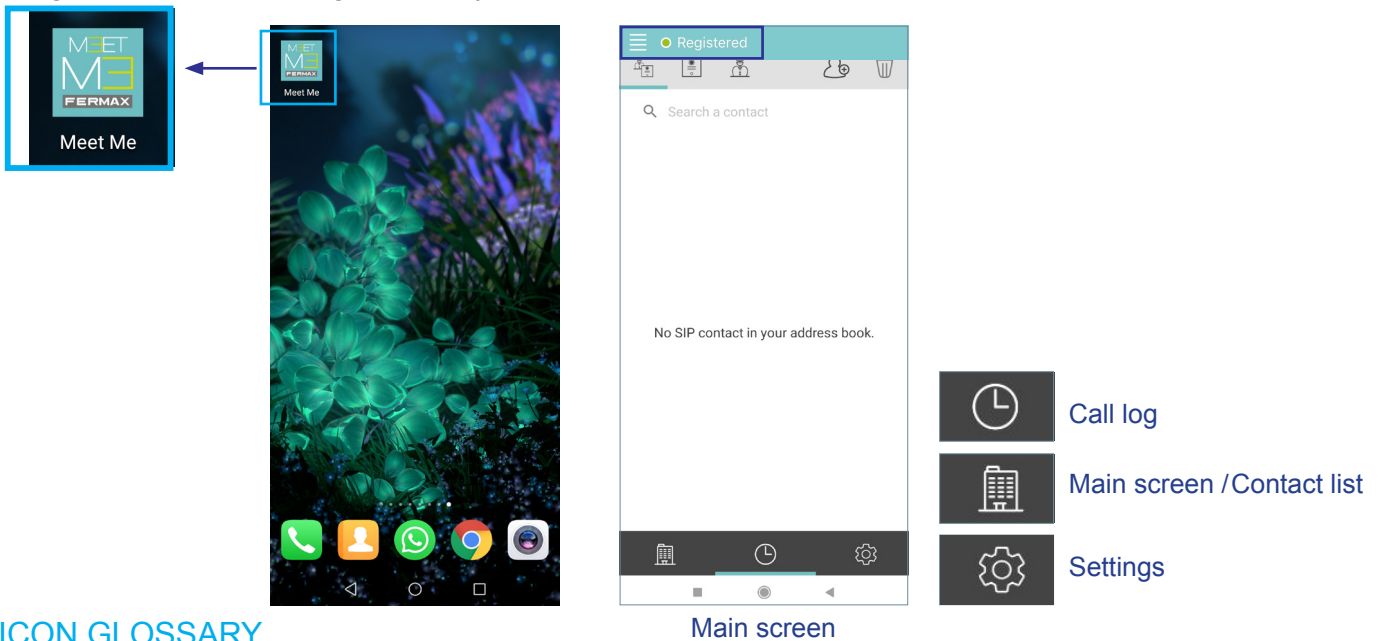













3. USING THE APP

Once registered, upon opening the APP, you will be taken to the main screen.



3.1 ICON GLOSSARY

-  Main Screen.
 -  To answer/make a call slide (Android) or press the button (iOs).
 -  To decline/end a call slide (Android) or press the (iOs) button.
- Once the call is answered, the conversation is activated in both directions and in hands-free mode. On this screen, it will be possible to adjust the following settings:
-  Pressing this icon, MUTE ON / OFF.
 -  Pressing this icon, HEADPHONES / HANDS-FREE.
 -  Pressing this icon, DISCONNECT VIDEO PANEL in the direction "panel -> smartphone".
 -  Pressing this icon, OPEN DOOR for the MAIN ACCESS
 -  Pressing this icon, OPEN SECOND ACCESS (1).
-  Call log.
 -  Pressing this icon displays the ENTIRE record of missed, received and made calls.
 -  Missed calls.
 -  Incoming calls.
 -  Made calls.
 -  Pressing this icon displays ONLY the log of missed calls.
-  Contact list.
 -  Press the icon to CREATE CONTACT.
 -  Panel/ Guard Unit: Displays both Panels and Guard Unit stored in the directory.
 -  Panel/ Guard Unit: Displays both Panels and Guard Unit stored in the directory.
 -  Trash: Delete.

3.2 CALL HANDLING

3.2.1 GENERAL

a) INCOMING CALLS.

Calls can be received with the APP in the background and with the mobile locked.

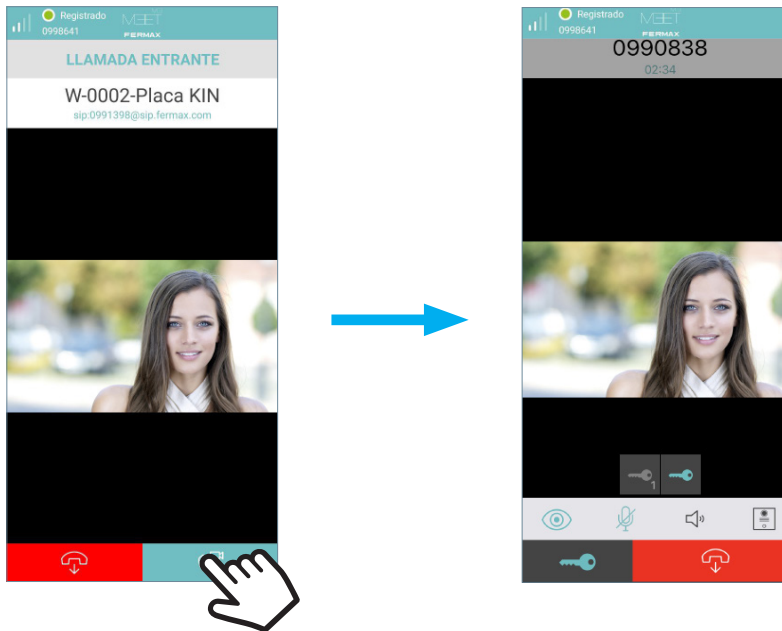

Press the button to accept incoming call.

Note:

- Press on the incoming notification to access this view.
- On the video CALL screen you can open the portal from the app to your visit by pressing the KEY icon. If there is more than one access on your portal and you have activated the AUXILIARY RELAY option in Settings, you can select the desired access to open, either the main or the secondary (auxiliary relay). *For more details, see page 8.*
- After pressing the button to open the door, user be asked for the security verification that is configured in the phone: configured on the phone: Pattern, PIN, Fingerprint or Facial Recognition.
- It is also possible to switch between the different IP cameras associated to the panels if the installation has this.



MISSED CALLS

For this, MEET ME has a PUSH notification service, which will also inform if there are missed calls. Clicking on the missed call takes you to the "call log". *See chapter 3.4 CALL LOG.*

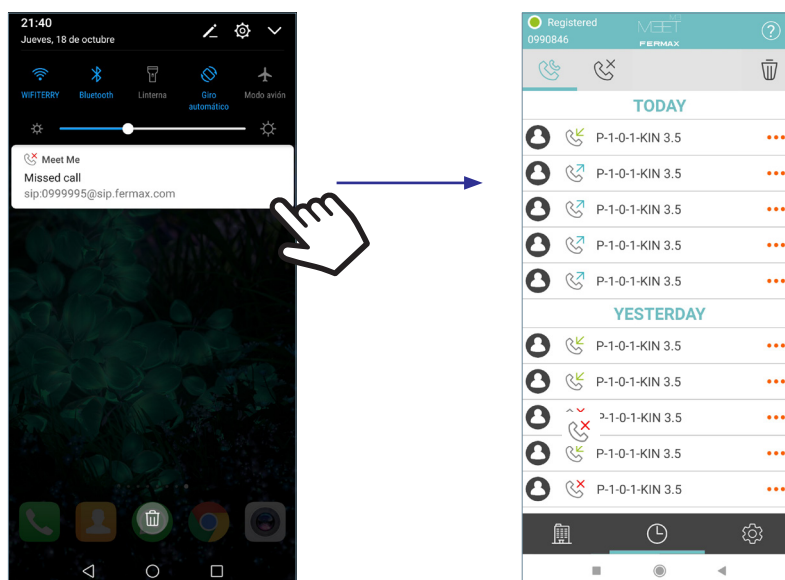

3.2.2 ANSWERING A CALL IN iOS FROM MEET ME V1.3

In our new version 1.3 of MEET ME for iOS, following Apple's guidelines, we have integrated [callkit](#) with the aim of improving both security and user experience when forwarding calls from your video door phone.

As a MEET ME user on iPhone or iPad you will notice that we have made the management of the video door phone calls on your mobile or tablet as similar as possible to any normal phone call, by introducing the following advantages:

Incoming calls are now received through notifications that are seamlessly integrated into the user interface, with native views and with the tune you had configured for the incoming calls. Never miss a call again because you didn't see or hear the notification.

a) With phone LOCKED

- You can answer the video door phone calls without unlocking your phone. In this case, after [accepting](#) the call in the notification you can establish an audio only communication with your visit, (WARNING, by default in the headset, if you want to be hands free you will have to press the speaker icon). If you want to see the image of your caller and open the door you will need to open the APP MEET ME by [pressing the MEET ME icon](#) available in the native view and unlock your phone.
- The calls from the video door phone are received in your mobile phone with the label "[MEET ME Audio](#)" under the name of the house you have configured in the MEET Board. The received calls will also be stored in the [Recent](#) Calls log of [the phone](#) and you can open the APP MEET ME directly from this list or from the Contact view of your home, for example when you want to perform an Auto Power On(See [chapter 3.3 AUTO-IGNITION - b\) From a contact in the agenda](#)).

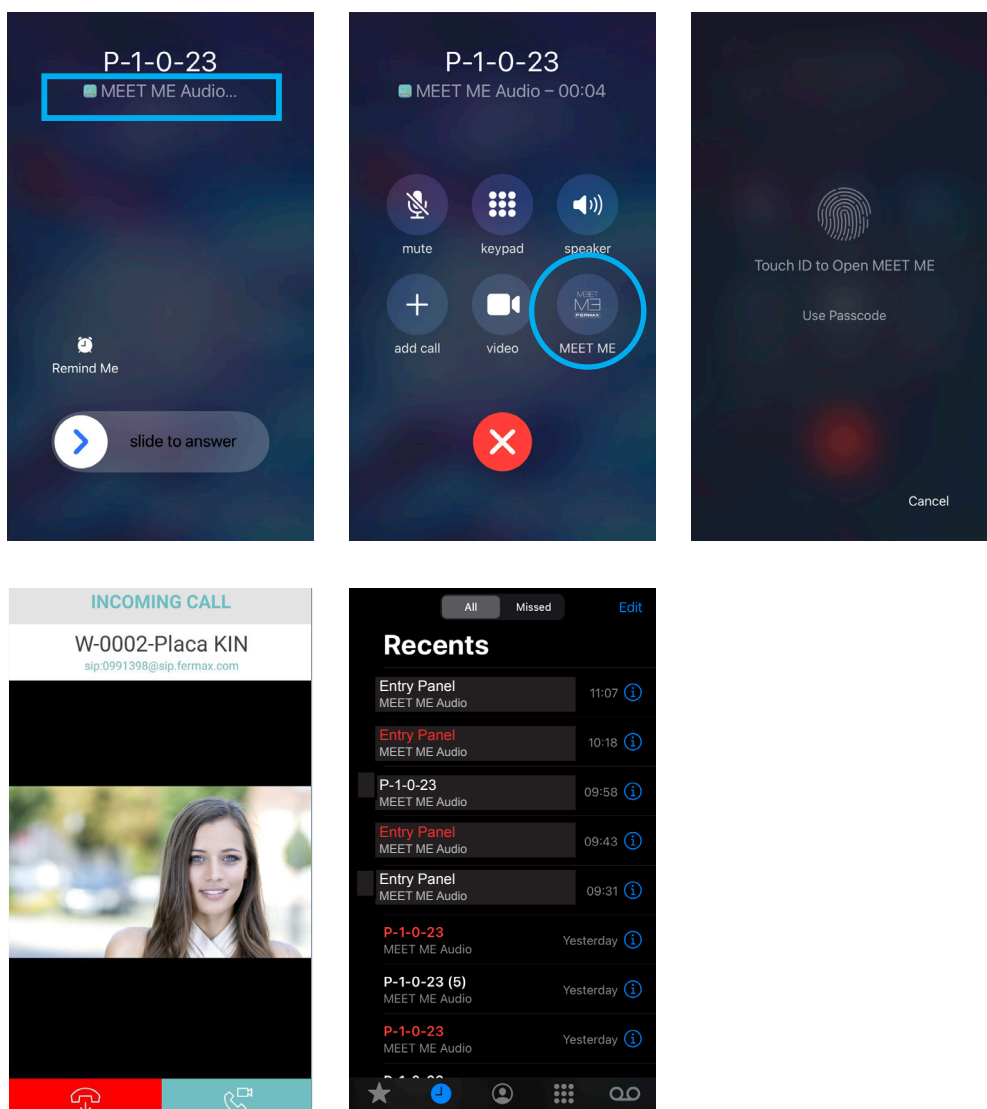

- We improved integration with the phone's native modes, such as "Do Not Disturb" and "Silent", as well as support for hands-free devices.

b) With phone UNLOCKED

- If the phone was not locked, as it does not require unlocking, after answering the [call notification](#), the APP MEET ME will open directly with the camera image and you can communicate with your visitor hands-free and open the door.

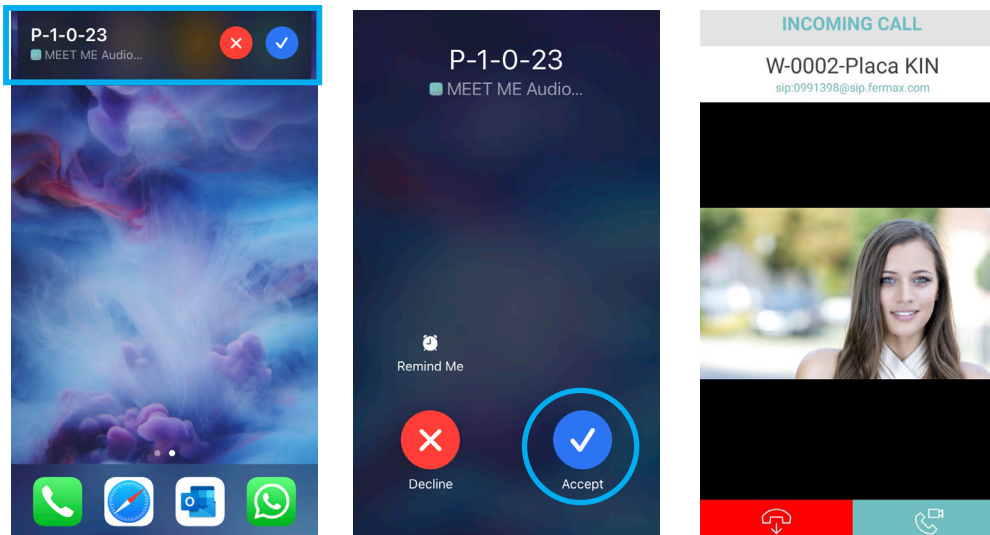

3.3 AUTO SWITCH-ON (OUTGOING CALLS)

a) From a contact from Main screen / List

Select the Contact List menu , select the contact and press the call icon.

Main screen

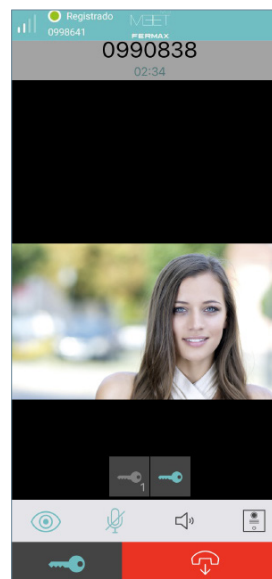
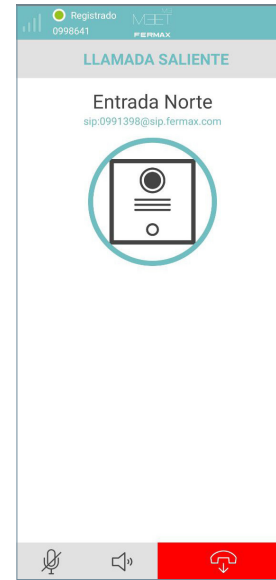
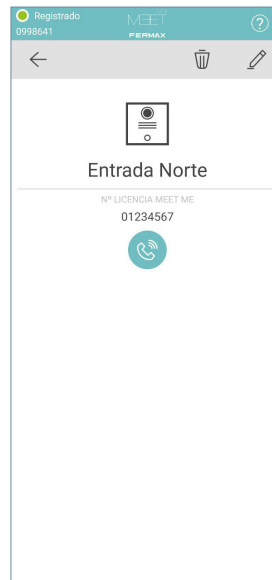

Important note:

- The plate has a sticker with an associated Fermax SIP account and in order to perform the AUTO SWITCH-ON, tenants should request the extension from their property manager or installer.

3.4 CALL LOG

The log of missed, incoming and made calls can be accessed by pressing this icon . This menu displays the history of all calls.

History of ALL calls

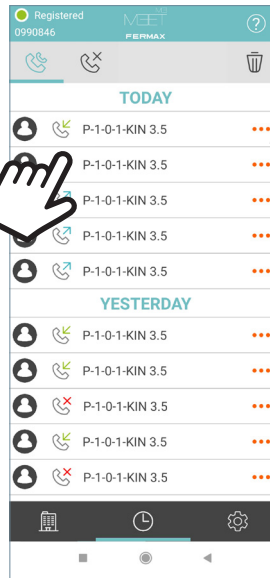

Pressing will make the call to that device



Pressing displays the time and duration of the call.



Pressing the icon displays the ENTIRE record of missed, received and made calls.



Missed calls.



Incoming calls.



Made calls.



Pressing the icon displays the ENTIRE record of missed, received and made calls.



History of ALL calls

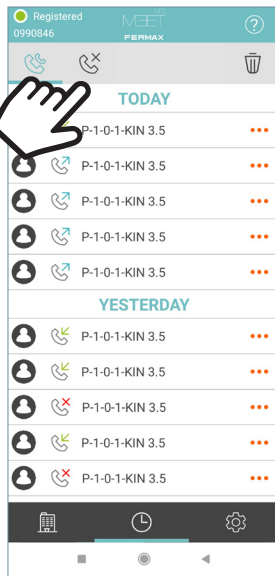

Record of missed calls

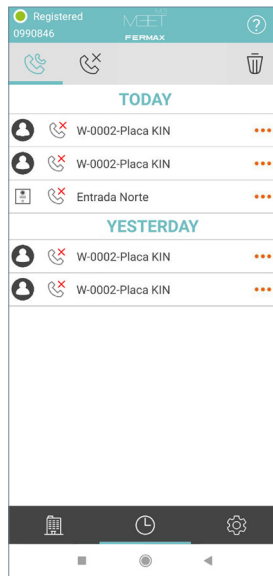

Record of missed calls

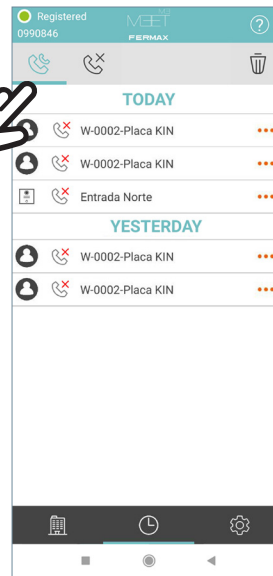

History of ALL calls

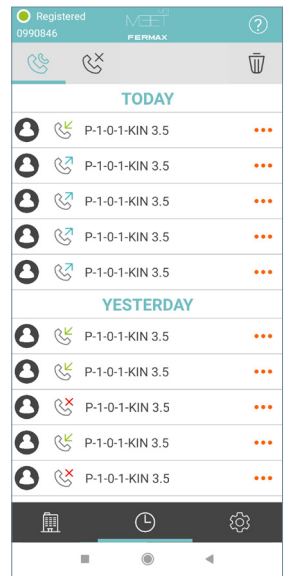



By pressing the icon, the call log is displayed with the possibility of selecting those to be deleted.

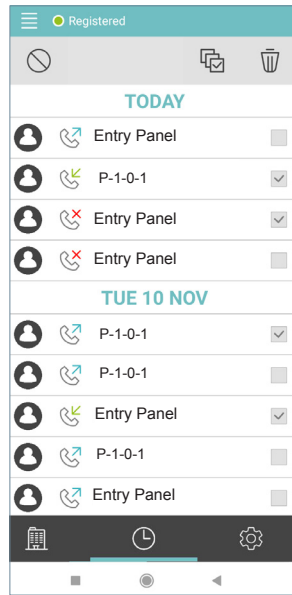
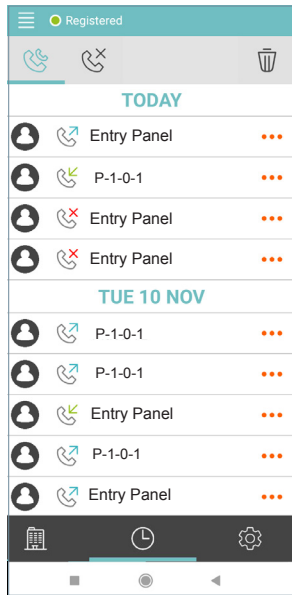

3.5 CONTACT LIST

It is possible to create contacts so that you can make **auto switch-on from panels**. The contact list can be accessed by clicking on the icon .

Main screen / Contact list

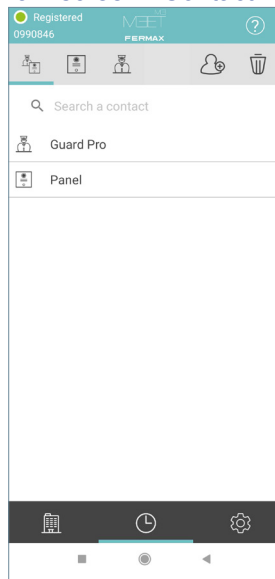

In this example there are two contacts: one panel and one guard unit.



Press the icon to CREATE CONTACT.

Add the name of the device you want to call and indicate the SIP address assigned to that device. Select whether the device is a door station or a guard unit. Then press .

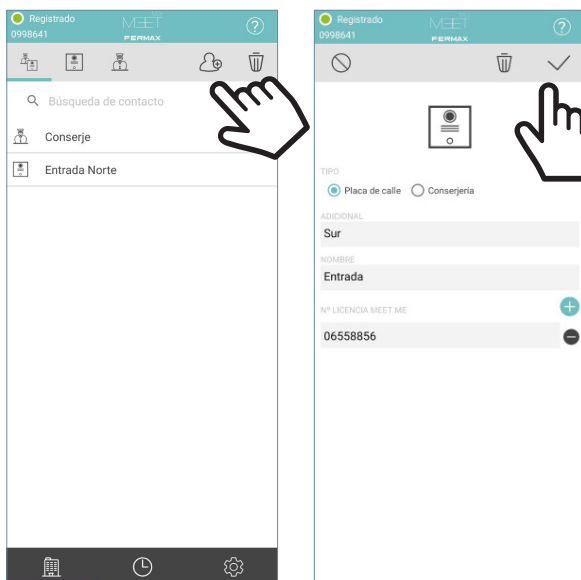

Important note:

- When you create a contact, it synchronizes in the cloud. Until the synchronization is successful, it will not appear in the list. Make sure the SIP address is correct.

3.6 CALL DETAILS

In order to know information about the quality and parameters during the call, click on the button at the top left of the screen.

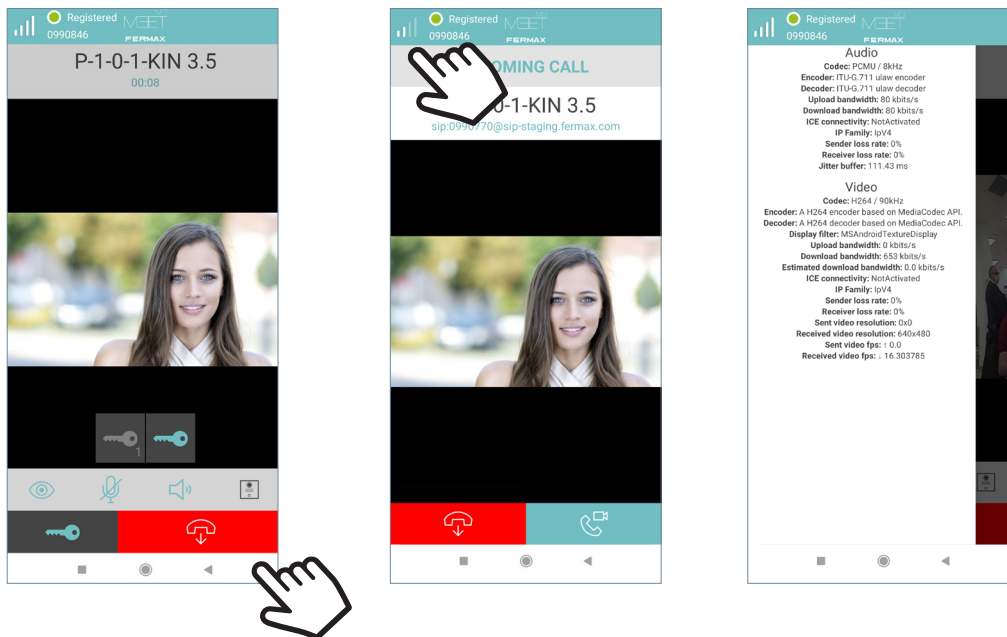

Press the button to accept incoming call.

3.7 AJUSTES DE LA APLICACIÓN

MEET Me accounts: licence in use on the mobile device.

Preferences:

- **Call reception:** enables or disables incoming calls on the smartphone.
- **Auxiliary Relays:** possibility to activate the opening of a second door during the call, if the installation has the necessary elements.
- **External Cameras:** possibility to view up to 4 additional IP cameras during the call, as long as the installation has the necessary elements and they have been configured.
- **Confirm opening:** enables or disables the biometric security check for door opening.
- **Hide keypad:** allows you to activate or deactivate the keypad menu for calls.
- **TS server:** possibility to register the app on an external SIP server.
- **App permissions:** displays information about the permissions requested by the app.
- **Log out:** log out of the Meet Me server. The application will ask for the licence number and password again when it is reopened.

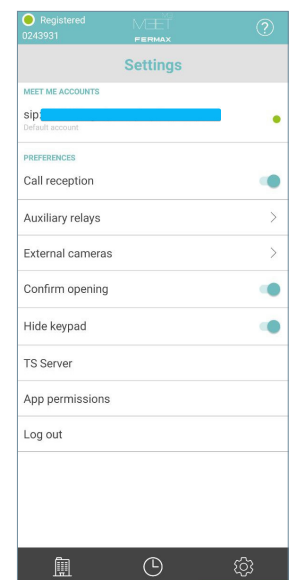

FERMAX

Avd. Tres Cruces, 133
46017 Valencia
Spain