

Tool list

No installation tools are provided with the AP. Prepare tools yourself as required.

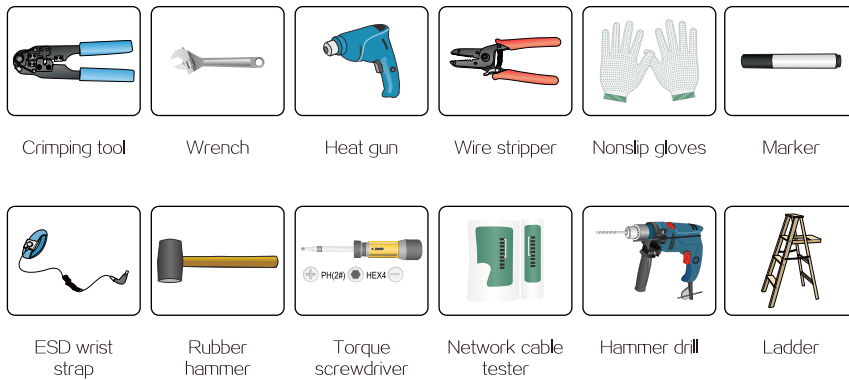

Installation accessories

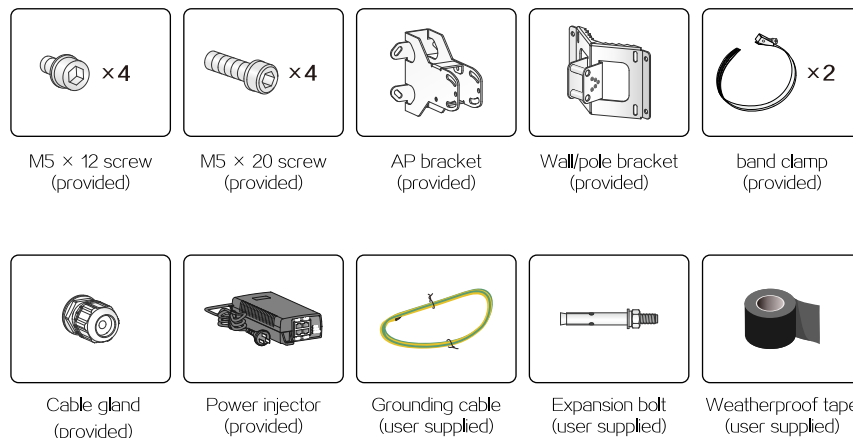

Device/mounting bracket dimensions

AP dimensions

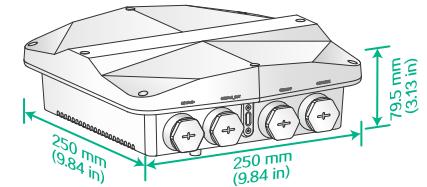

AP bracket dimensions:

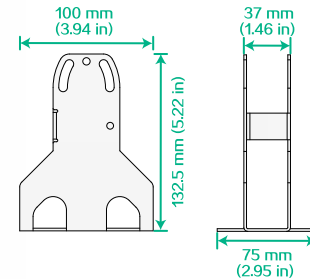

Wall/pole bracket dimensions:

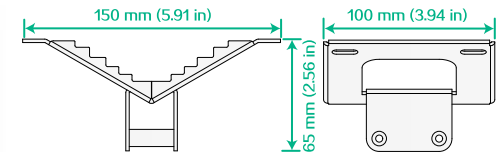

Attaching the AP bracket to the AP

- The AP bracket supports both horizontal and vertical installations.
- To mount the AP on a vertical pole, make sure the vertical pole mounting arrow on the AP bracket points up.
 - To mount the AP on a horizontal pole, make sure the horizontal pole mounting arrow on the AP bracket points up.
 - To mount the AP on a wall, you can orient the AP bracket horizontally or vertically as required.

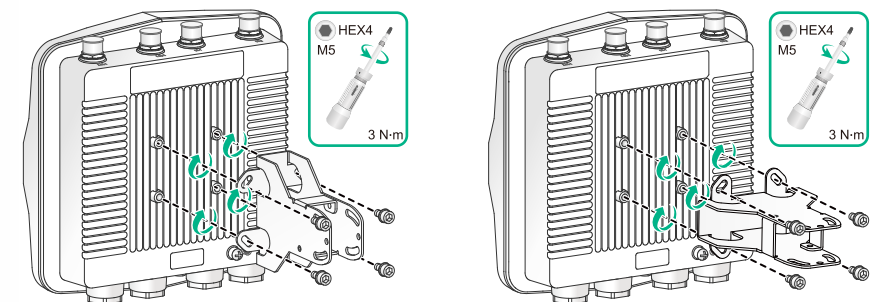

Align the AP bracket with the screw holes on the rear of the AP, and then use M5 × 12 screws to attach the AP bracket to the AP.

Mounting the AP on a wall

The following procedure mounts the AP on a wall with the vertical pole mounting arrow on the AP bracket pointing up. To mount the AP on a wall with the horizontal pole mounting arrow on the AP bracket pointing up, adjust the installation direction of the wall/pole bracket accordingly.

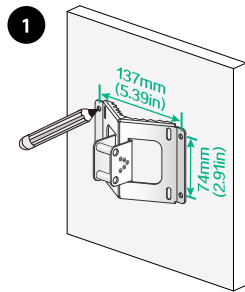

Use the wall/pole bracket to mark four installation holes on the wall.

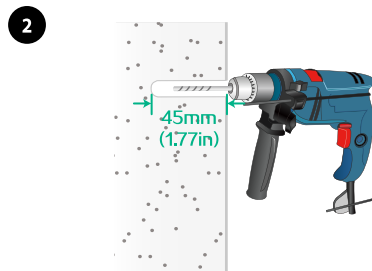

Drill holes with a diameter of 8 mm (0.32 in) at the marked locations.

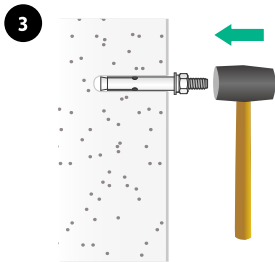

Tap an expansion bolt with a rubber hammer into each hole.

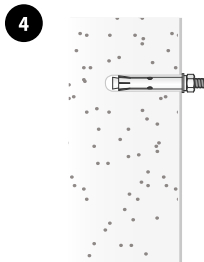

Fasten the nut on each expansion bolt to expand the expansion sleeve.

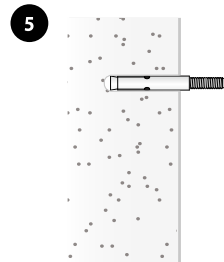

Remove the nut and washers from each bolt.

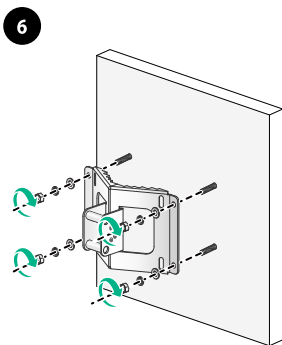

Align the installation holes on the wall/pole bracket with the bolts on the wall, and then fasten the nuts and washers on the expansion bolts to secure the wall/pole bracket to the wall.

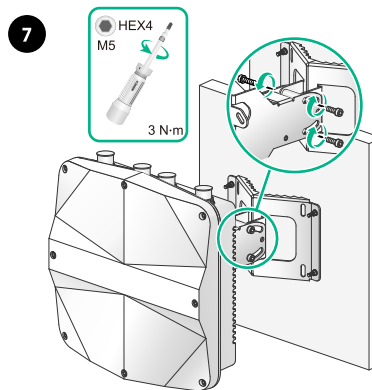

Orient the AP with the vertical pole mounting arrow on the AP bracket pointing up. Use M5 × 20 screws to secure the AP bracket attached to the AP to the wall/pole bracket.

Mounting the AP on a vertical pole

The provided band clamps support poles with a diameter of 60 to 80 mm (2.36 to 3.15 in). If the diameter of the pole is not in the range, prepare band clamps yourself.

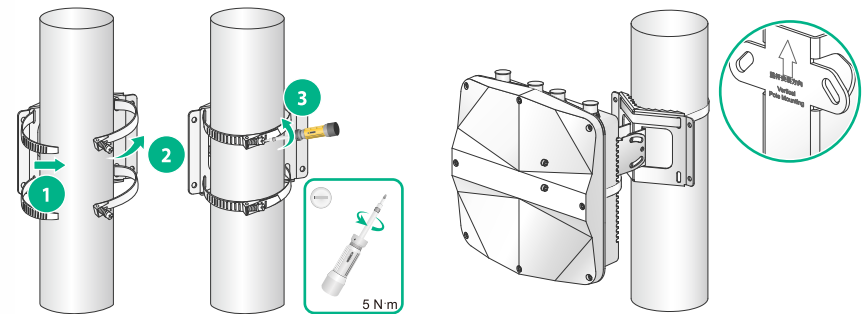

Use band clamps to secure the wall/pole bracket to the vertical pole.

Orient the AP with the vertical pole mounting arrow on the AP bracket pointing up. Use M5 × 20 screws to secure the AP bracket attached to the AP to the wall/pole bracket.

Mounting the AP on a horizontal pole

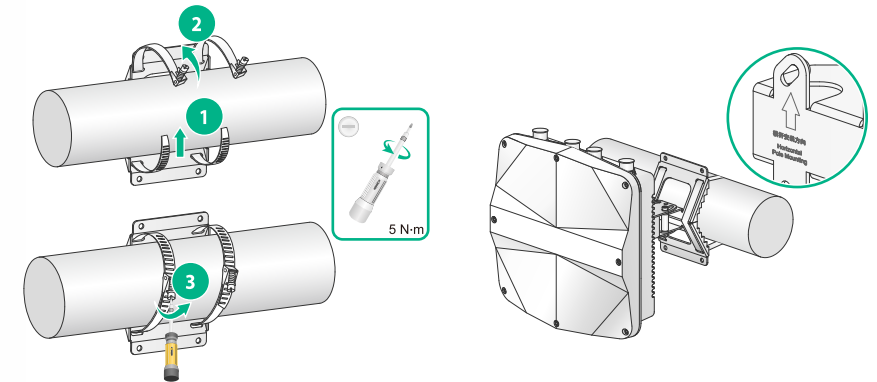

Use band clamps to secure the wall/pole bracket to the horizontal pole.

Orient the AP with the vertical pole mounting arrow on the AP bracket pointing up. Use M5 × 20 screws to secure the AP bracket attached to the wall/pole bracket.

Adjusting the AP angle

After the AP is installed, you can adjust the AP angle by loosening the four screws that secure the AP bracket and wall/pole bracket.

- If the AP is installed with the vertical pole mounting arrow on the AP bracket pointing up, you can adjust the AP to the desired elevation angle (the adjustment angle must not exceed 60 degrees).
- If the AP is installed with the horizontal pole mounting arrow on the AP bracket pointing up, you can adjust the AP to the desired azimuth angle (the adjustment angle must not exceed 60 degrees).

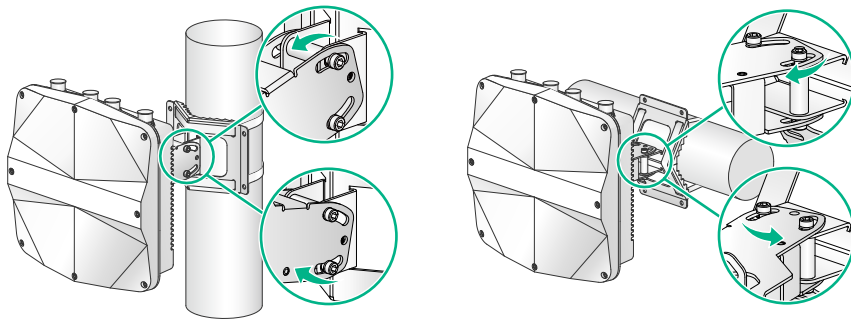

Connecting cables

- A liquid tight adapter is composed of a weatherproof connector, a sealing nut, and a rubber split sealing washer.
- Make sure you attach the adhesive side of the tape to the cable connector.
- Pull the tape as needed for overlap.
- Start wrapping at the top of the connector, and overlap the tape to half-width. Avoid creases or wrinkles and press the tape against the connection so that there are no gaps. Smooth each wrapped layer with your hands to ensure full adhesion.
- To prevent device damage, attach weatherproof caps tightly to unused connectors.

1. Connecting an Ethernet cable

Use Category-5e or above Ethernet cables only. As a best practice, use shielded twisted pair (STP) cables.

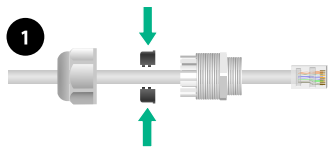

Disassemble the liquid tight adapter and detach the rubber split sealing washer, and then feed the Ethernet cable through the connector.

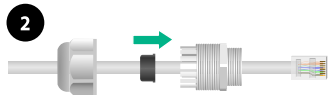

Attach the split sealing washer to the cable, connect the Ethernet cable to the target port on the AP, and insert the sealing washer into the weatherproof connector.



Use a wrench or wear nonslip gloves to fasten the sealing nut and the weatherproof connector.

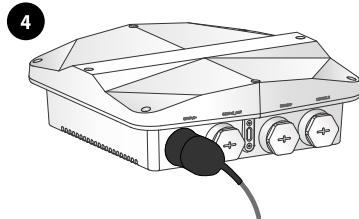

Start wrapping at the top of the connector until the entire connector is wrapped. Smooth the tape edges to ensure full adhesion.

2. Connecting a fiber cable

- Before connecting a fiber cable, remove the dust caps from the fiber connectors and keep the caps secure.
- To use a fiber pigtail that does not have any protective sleeve, first use weatherproof tape to wrap the fiber pigtail before you connect the fiber pigtail.

- To avoid cable damage, do not pull the fiber cable with excessive force.
- To avoid affecting fiber performance, make sure the fiber cable is not bended or folded when fastening the sealing nut.



Use weatherproof tape to wrap the fiber connectors around the rubber boots, build up the fiber cable diameter near the opening in the split sealing washer. Smooth the tape edges to ensure full adhesion.

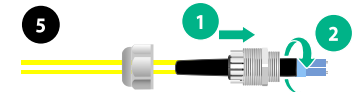

Adjust the weatherproof connector to ensure that the fiber is not bended or folded, and then fasten the weatherproof connector.

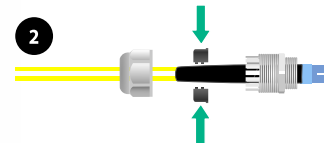

Disassemble the liquid tight adapter and detach the rubber split sealing washer, feed the fiber cable through the connector, and then attach the split sealing washer to the cable.



Use a wrench or wear nonslip gloves to fasten the sealing nut.

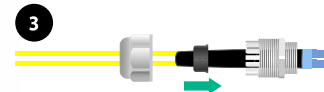

Insert the sealing washer into the weatherproof connector.

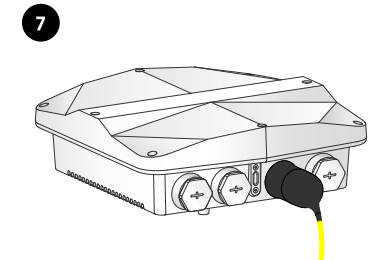

Start wrapping at the top of the weatherproof connector until the entire connector is wrapped. Smooth the tape edges to ensure full adhesion.



Attach a transceiver module to the SFP port, and then connect the fiber cable to the transceiver module.

Connecting the grounding cable



Correctly connecting the grounding cable is crucial to lightning protection and EMI protection. No grounding cable is provided with the AP. Prepare one yourself. Make sure the cross sectional area of the grounding cable is over 6 mm² (0.0093 in²).

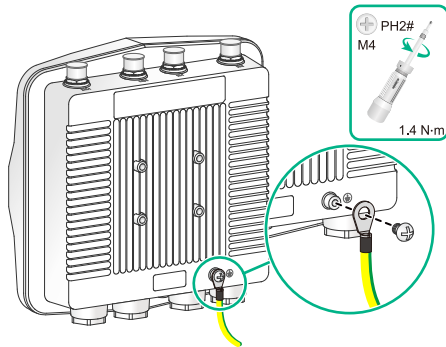

Use the grounding screw to attach the ring terminal of the grounding cable to the grounding point on the AP. Connect the other end of the grounding cable to a reliable earth ground.

Powering the AP by using a PoE device



- Only the GE1 port of the AP supports IEEE 802.3at PoE input.
- To avoid damage to the PoE_OUT port, do not connect a cable carrying power to the port.
- The switch that provides PoE power supply to the AP must meet outdoor lightning protection requirements.

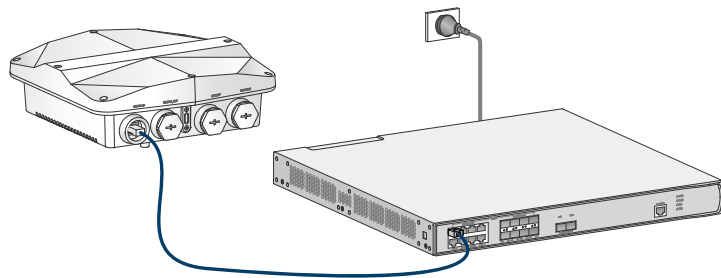

Powering the AP by using a power injector



- Before connecting power to the AP, make sure the grounding cable is correctly connected.
- The PoE1 port on the PoE injector is connected to the uplink network through the LAN1 port, and PoE2 through LAN2. As a best practice, use a PoE injector to supply power to only one AP.
- The provided power injector is not waterproof. To use the power injector outdoors, install it in a waterproof enclosure and make sure water will not enter the power injector along the power cord or network cable.

1. Using a copper cable for uplink network connection

You can use the PoE1 or PoE2 port on the power injector to connect the AP. This procedure connects PoE1.

- (1) Connect the PoE1 port on the power injector to the GE1 port of the AP.
- (2) Connect the LAN1 port on the power injector to an Ethernet switch or AC.

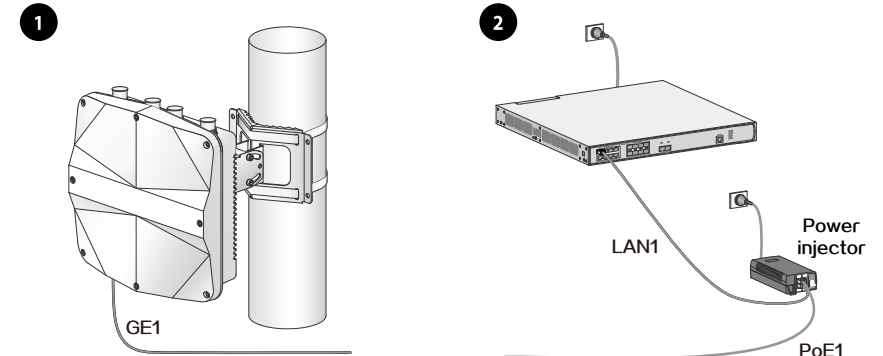

2. Using an optical fiber for uplink network connection

- (1) Use an optical fiber to connect the SFP port on the AP to an Ethernet switch or access controller.
- (2) Connect the power input end of the power injector to an AC power source.
- (3) Connect the PoE1 port on the injector to the GE1 port of the AP.

