



SPA-P100B

IP Pendant Speaker



Key Features

- Amplifier: Built in 10W Class D
- Power: PoE(IEEE 802.3 af type 1 Class 3) , PoE+(IEEE 802.3 at type 2 Class 4)
- Internal memory: 1 GBytes
- Frequency Range (-10dB): 130Hz~20kHz
- Max. Sound Pressure Level : 101dB
- Sensitivity (1Watt): 91dB
- Supported Protocols: IPv4, HTTP, SIP, mDNS, DNS, NTP, TCP, UDP, DHCP, ARP, ICMP
- TTS: English(US, UK), German, French, Spanish, Russian

SPA-P100B

IP Pendant Speaker



Specifications

| | |
|----------------------------------|---|
| Product | |
| Type | IP Pendant Speaker |
| Amplifier | |
| Description | Built in 10W Class D |
| Network | |
| Ethernet | 10/100 Base-T |
| Memory | |
| Internal Memory | 1 GBytes |
| External Memory (Micro SD) | SDHC upto 32GB (SANDISK) |
| Contact | |
| Contact Input. Dry contact | One channel |
| Contact Output. Dry contact (NO) | One channel |
| General | |
| Operating Temperature | -20 ~ +50°C (-4°F ~ +122°F) |
| Operating Humidity | 10~85% RH (Non-Condensing) |
| Weight | 2.1Kg |
| Size | Φ269*256(H)mm |
| Color | Black/White |
| Certificate | EMC : FCC Part 15 Subpart B, ICES-003 Safety : UL 62368-1, CAN/CSA 62368-1 |
| Power | |
| PoE | PoE (IEEE 802.3 af type 1 Class 3) |
| PoE+ | PoE+(IEEE 802.3 at type 2 Class 4) |
| Embedded MIC | |
| Input Sensitivity | Sound Level Meter |
| Frequency Response | Sound Level Meter |
| Audio | |
| Supported Audio Format | WAV, MP3 in mono/stereo from 64 kbps to 320 kbps. Sampling rate from 16 kHz up to 48 kHz |
| Speaker | |
| Speaker Component | 2Way 8" LF Drive & 2" HF Driver. Passive type |

Design and specifications are subject to change without notice. The latest product information / specification can be found at HanwhaVision.com

Hanwha Vision is formerly known as Hanwha Techwin.

| | |
|---|---|
| Max. Sound Pressure Level (PoE) | 97dB |
| Max. Sound Pressure Level (PoE+) | 101dB |
| Frequency Range (-10dB) | 130Hz~20kHz |
| Sensitivity (1Watt) | 91dB |
| Coverage Pattern | (HxV) : 130°(1kHz) / 60°(4kHz) |
| Network Protocol | |
| Security | Password protection : admin,setup,user,guest (sha-2, Digest authentication, User access log) Digest authentication, User access log |
| Supported Protocols | IPv4, HTTP, SIP, mDNS, DNS, NTP, TCP, UDP, DHCP, ARP, ICMP |
| System Integration | |
| API (Application Programming Interface) | SUNAPI |
| Multi-source Dynamic PA control | Multi-source up to 48 (Multicast) (Audio 24CH + Mic 24CH) Up to 256 Zone Control (Multicast) Up to 20 Zone Control (Unicast) Up to 255 Groups |
| VoIP | Tested with SIP clients such as Grandstream, Yealink, Cisco, MicroSIP softphone and PBX supplier such as Asterisk Tested with SIP client such as Grandstream and PBX supplier such as Grandstream Supported SIP features: DTMF (RFC2833) Supported codecs: PCMU, PCMA, speex/8000, speex/16000 |
| TTS | English(US, UK), German, French, Spanish, Russian |
| Audio Monitoring | Speaker test by graphic level meter (Built in test tool) |
| Event & Preset | Virtual Contact, Dry contact |
| Functional Monitoring | Connection verification, Built-in system logging |

SPA-P100B

IP Pendant Speaker



CAD

Unit:mm [inch]

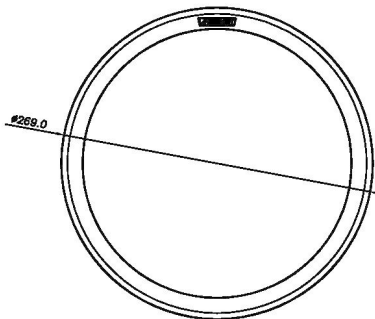
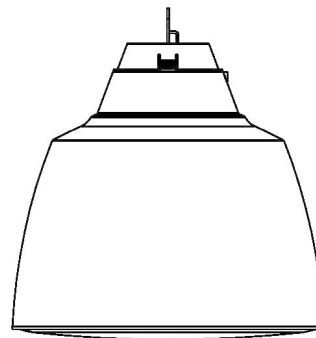
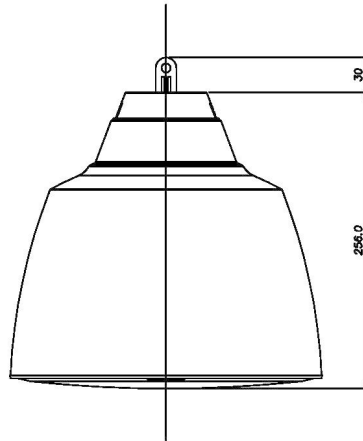

| | | |
|------------------|------------|------------|
| 3 | MODEL2 | |
| 2 | MODEL1 | |
| 1 | SPA-P100BW | 23.05.10 |
| No. | MODEL NAME | DATE |
| Unit:mm[inch] | | SCALE: 1/1 |
| © Hanwha Techwin | | |

© Hanwha Techwin Co.,Ltd. All rights reserved.