

# Wall&Pole Mount

SBP-160WMW1  
SBP-140WMW  
SBP-125WMW1



## Installation Precautions

- Make sure that the installation place can endure at least 4 times of the total weight of the Wall&Pole Mount and Camera.
- Each anchor screw must be capable of withstanding an extraction force of 700 kg.
- We recommend to use this mount to install indoor because this model does not support waterproof. When installed outdoor, then please treat the connected cable waterproof. (More detailed cable waterproof guideline is remarked in camera user manual)

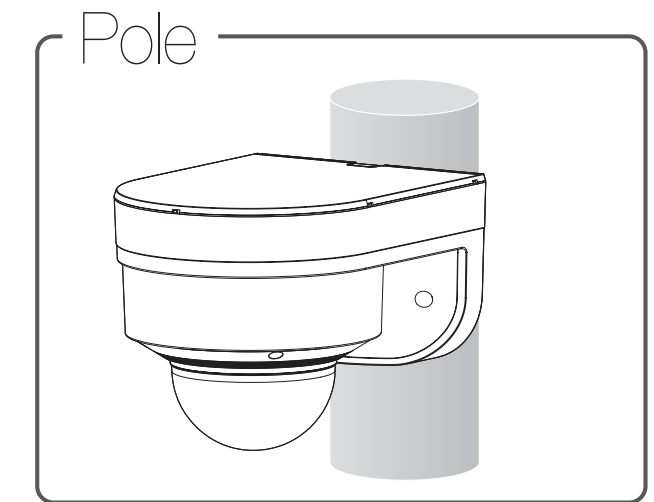
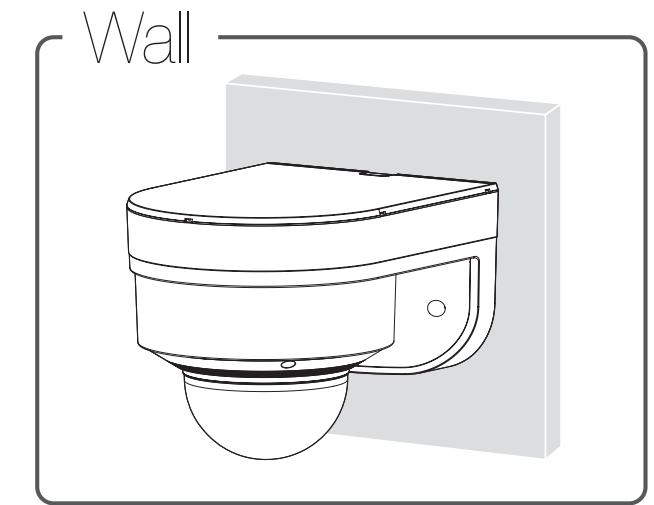

## Package

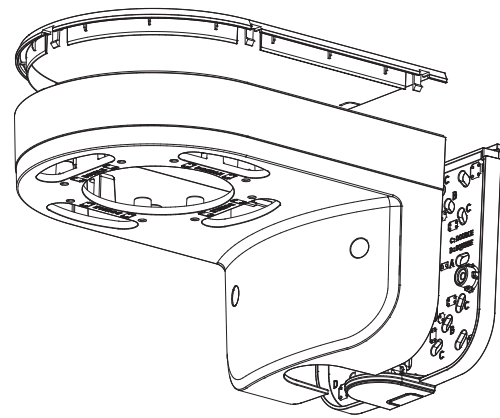

WALL&POLE MOUNT



SBP-160WMW1 (4EA)  
SBP-140WMW (4EA)  
SBP-125WMW1 (2EA)

## Optional Accessory

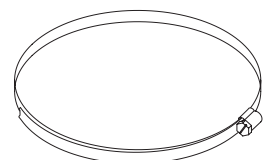

Steel Strap  
(ø80~ø160)

## Mounting Hole by Camera Size

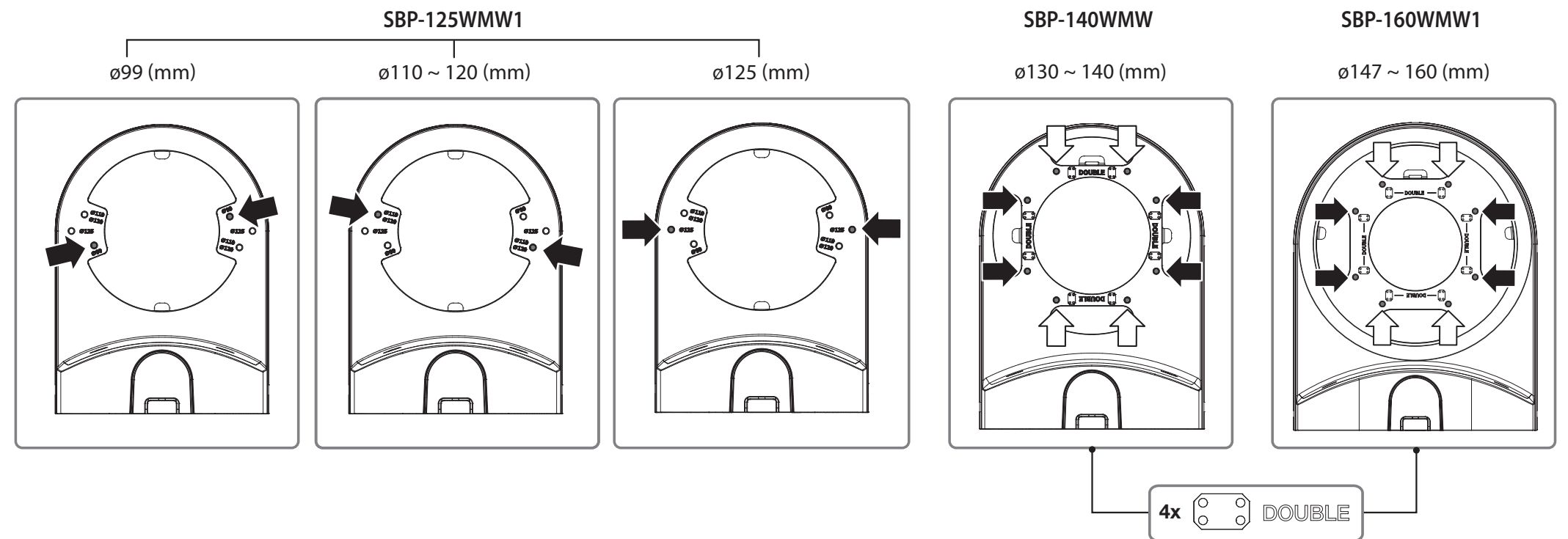

1 (Wall)

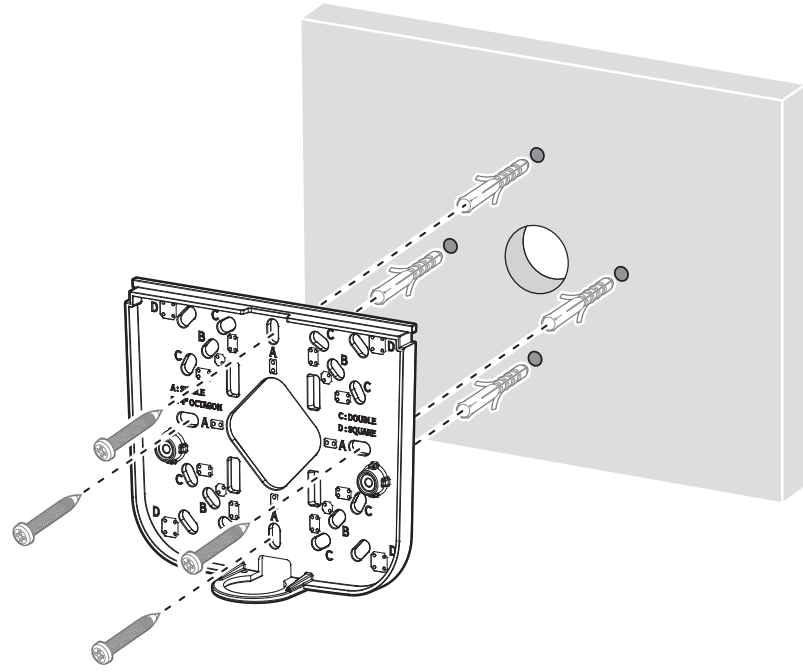

(Pole)

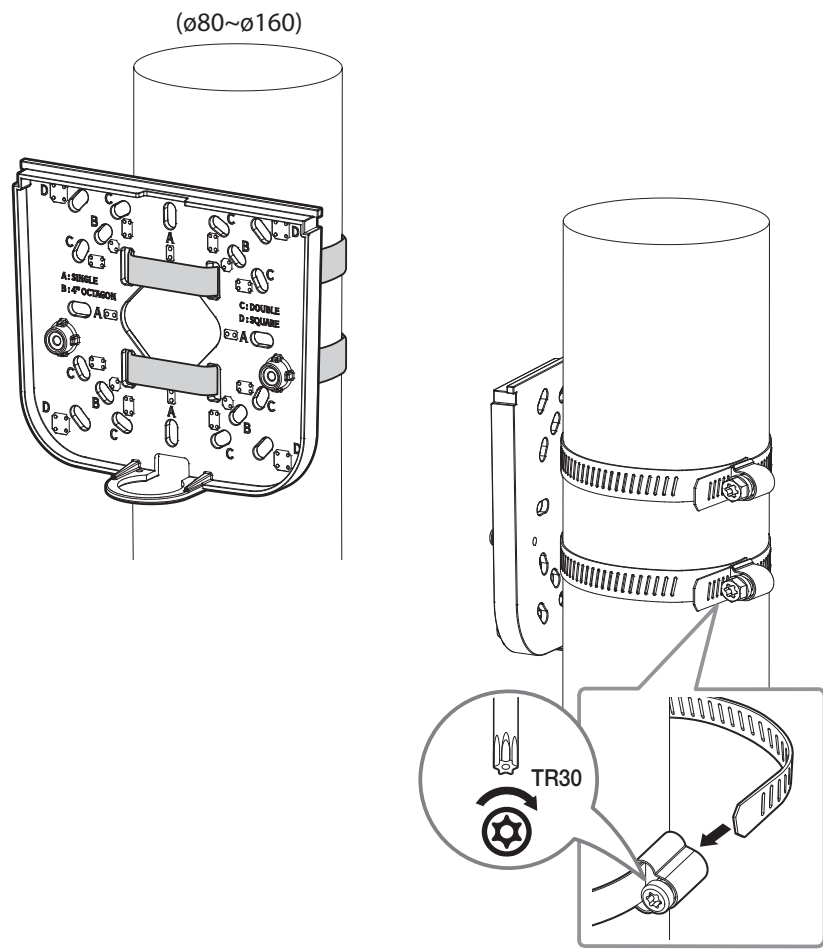

2

A

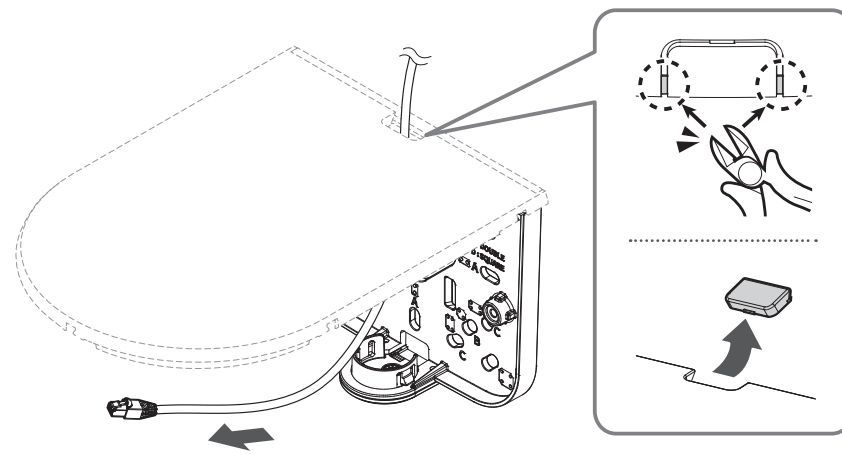

B

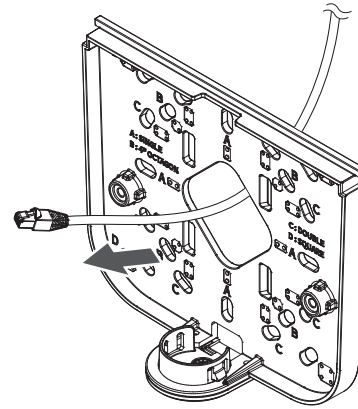

C

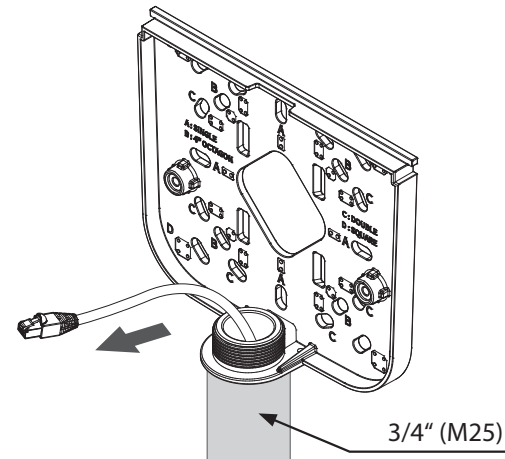

D

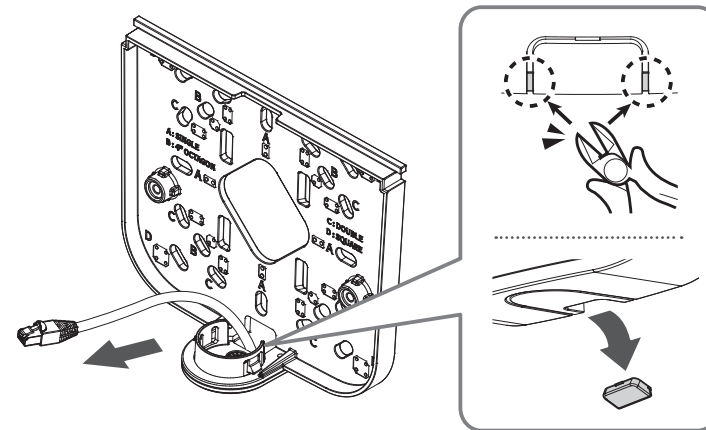

3

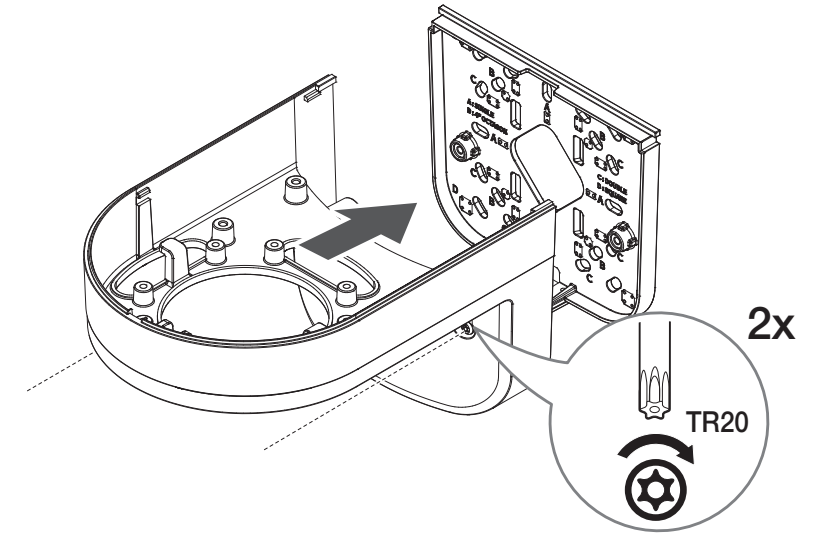

4

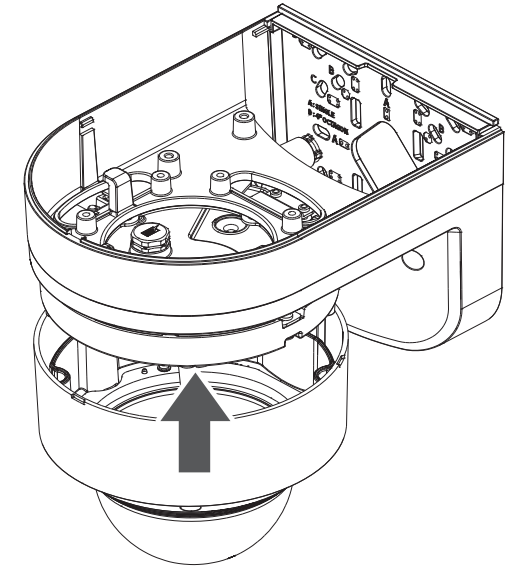

5

