

SPI-50

IR Illuminator



Key Features

- Compatible IR Illuminator for TNU-6320/6321
- IR light covers whole FoV range of TNU-6320/6321
- Wavelength : 850nm

Dimensions

Unit : mm (inch)

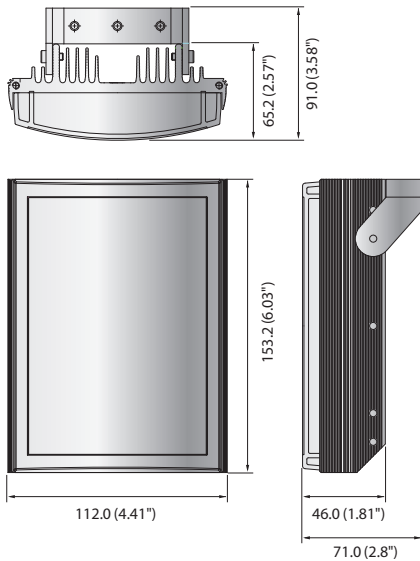

	SPI-50
OPERATIONAL	
LED Type	IR LED
Distance Performance	200m (656.17ft)
Number of LED	9ea
Wavelength	850nm
Control	Via remote control : day&night, photocell sensitivity
COMMUNICATION	
Between Camera & Illuminator	RS-485 9600bps
Illuminator Identification	Fixed address 1
EXTERIOR	
Dimensions (WxHxD)	112.0x 153.2 x 65.2mm (4.41" x 6.03" x 2.57")
Weight	Illuminator : 0.9kg (1.98 lb), 1ea / Bracket : 0.43kg (0.95 lb)
Material	Aluminum + PC Cover
ELECTRICAL	
Power	24V AC (±10%)
Power Consumption	Max. light : 24 W
ENVIRONMENTAL	
Operational Temperature	-40°C ~ +60°C (-40°F ~ 140°F)
Certification	EMC (FCC, CE, VCCI, RCM, KC)
Ingress Protection	IP67

* The latest product information / specification can be found at hanwha-security.com
 * Design and specifications are subject to change without notice.

* When TNU-6320/6321 +SPI-50 is used,
 1) IR light intensity is adaptively controlled by TNU-6320/6321.
 2) IR light covers whole FoV range of TNU-6320/6321.

