

Road AI LPR/ANPR Cameras **INSTALLATION GUIDE**



- 1 OVERVIEW OF THE CAMERA
- 2 PRE-INSTALLATION
- 3 INSTALLING AND POSITIONING CAMERA
- 4 CONFIGURING YOUR CAMERA
- 5 CAMERA SPECIFICATION

Model **HT230C**

Color GRAY

Brand **HTV**

Type **SUV**

LPN **HT-777-WS**

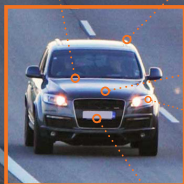

CONTENTS

1

OVERVIEW OF THE CAMERA

Camera selection (Between various P-series and T-series)

2

PRE-INSTALLATION

- 2.1 Choosing Location
- 2.2 Overhead and Roadside mounting
- 2.3 Vehicle speed and number of lanes covered
- 2.4 Daytime and Nighttime
- 2.5 Power requirements
- 2.6 Mounting Options

3

INSTALLING AND POSITIONING CAMERA

- 3.1 Camera Installation
- 3.2 Adjusting Plate Tilt Angle

4

CONFIGURING YOUR CAMERA

- 4.1 Field of View
- 4.2 Configuring Initial Camera Settings
- 4.3 Focus
- 4.4 Pixel width of License/Number plate
- 4.5 Examples of Proper and Improper Installation

5

CAMERA SPECIFICATION



1

OVERVIEW OF THE CAMERA

The TNO-7180RLP License Plate Recognition (LPR) camera system is a high-performance solution for those who don't want to miss license plates.

Equipped with an industry-leading image sensor and optical zoom, the TNO-7180RLP delivers unprecedented performance for accurate license plate and vehicle maker and model recognition.

A camera with a global shutter ensures clear image capture of license plates moving at speeds as fast as 200 kmh (124 mph). A lens capable of up to 18x magnification means greater ability to scan vehicles both near and far.



Camera selection (Between various P-series and T-series)

P series and T series cameras are for License Plate Recognition, and the T series is optimized for recognizing license plates of high-speed vehicles up to 200 kmh (125 mph).



TNO-7180RLP



PNV-A9081RLP



PNO-A9081RLP



PNB-A9001LP
(* with 50mm lens)

LPR(ANPR) CAMERAS

LPR Usage Conditions	Highway	Community Traffic	Parking Application	City Traffic
Speed Description	High speed	Moderate speed	Low speed	Regular speed
Lane Coverage	Up to 2 lanes (5m/18ft Wide)	1 lane (3.6m/12ft Wide) (with built in IR)	1 lane (3.6m/12ft Wide) (with built in IR)	Up to 2 lanes (5m/18ft Wide)
Speed limit	Up to 200kmh (125mph)	Up to 70kmh (45mph)	Up to 40kmh (25mph)	Up to 100kmh (65mph)
Min. Forward Distance	27m (90ft)	12m (38ft)	10m (33ft)	16m (52ft)
Max. Forward Distance	46m (150ft)	12m (40ft)	13m (45ft)	36m (120ft) (with Ext. IR)
Max. Horizontal Angle	15°	25°	30°	25°
Max. Vertical Angle	15°	25°	30°	25°
Horizontal Offset	Up to 4m (12ft)	Up to 5m (18ft)	Up to 7m (24ft)	Up to 7m (24ft)
Camera Height	Up to 12m (39ft)	Up to 5m (18ft)	Up to 7m (24ft)	Up to 7m (24ft)
Vehicle Recognition	Make : 70+ Makes Model : 600+ models Color : 11 colors	Make : 70+ Makes Model : 600+ models Color : 11 colors	Make : 70+ Makes Model : 600+ models Color : 10 colors	Make : 70+ Makes Model : 600+ models Color : 11 colors

NOTE: for the US version, lane coverage is up to one lane and the speed limit is up to 100 mph for the high-speed highway solution.

2 PRE-INSTALLATION

2.1 Choosing Location

The LPR (License Plate Recognition) / ANPR (Automatic Number Plate Recognition) Technology running on this camera will provide you with the best results when following the recommended installation requirements below.

Fig. 1

Camera shown from side

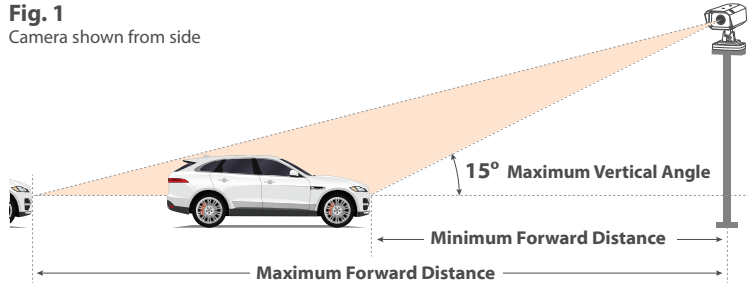

Recommended

The maximum vertical angle is **15 degrees** for highway installations. In the city center, where vehicles travel slower than **120 km/h** (75 mph), the maximum vertical angle can be up to **25 degrees**.

Maximum Forward Distance depends on lens zoom, however, should not exceed **46 m / 150 ft** considering effective IR range.

Fig. 2

Example of installation at a height of 6 m

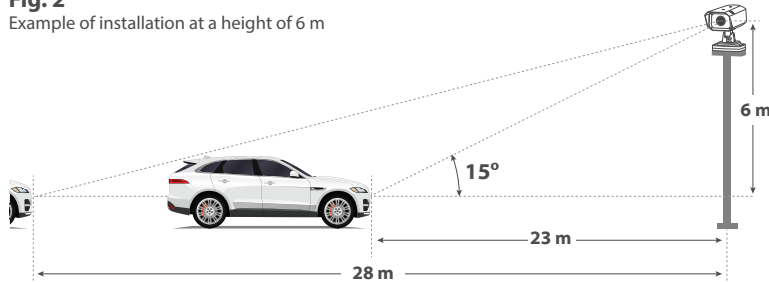

2.1 Choosing Location (Continued)

FORWARD DISTANCE TABLES

The **orange dots** on the tables below are recommended installation measurements.

		Forward Distance (m)						
		15 (49.2')	20 (65.6')	25 (82.0')	30 (98.4')	35 (114.8')	40 (131.2')	45 (147.6')
Camera Height (m)	4(13.1')	●	●	●	●	●	●	●
	6(19.6')		●	●	●	●	●	●
	8(26.2')				●	●	●	●
	10(32.8')					●	●	●
	12(39.3')							●

* Daytime condition with built in IR.

2.1 Choosing Location (Continued)

Recommended

15 or 25 degrees Maximum Horizontal Angle

Fig. 3

Camera shown from top

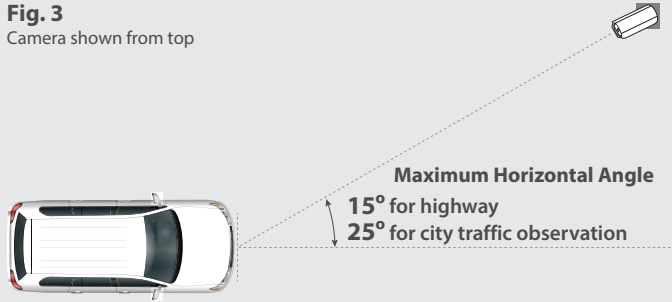
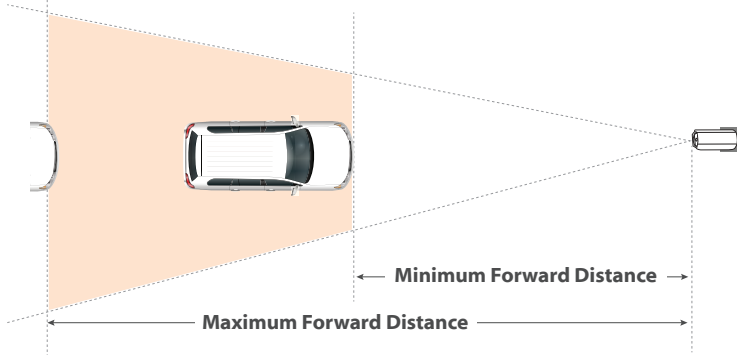

Fig. 4



The 3MP mode can cover up to 2 lanes.

Normally, setting recognition zone (see orange frame below) in lower half of camera view is sufficient and favours app performance.

Best results are achieved when single row number plate width has fit the criteria. Greater width may affect performance.

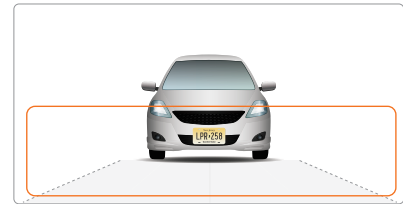

All the license Plate that are meeting the pixel criteria as below will be recognized in the selected area.

- **130-300 pixels** for regular EU plates
- **80-300 pixels** for US plates without stacked symbols (small ones)
- **160-300 pixels** for US plates with stacked symbols

Color coded pixel counts are available in the settings section of Road AI.

2.2 Overhead and Roadside mounting

In overhead mounting, the LPR camera is mounted directly above the vehicle path. Refer to the following table for the maximum mounting height and corresponding forward distance to license plate detection area for each LPR camera.

Improper Installation

2m/(7ft) Mounting Height
10m/(33ft) Forward Distance

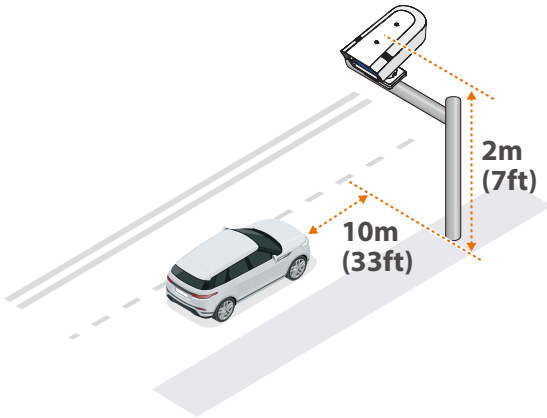

Proper Installation

6m/(20ft) Mounting Height
25m/(82ft) Forward Distance

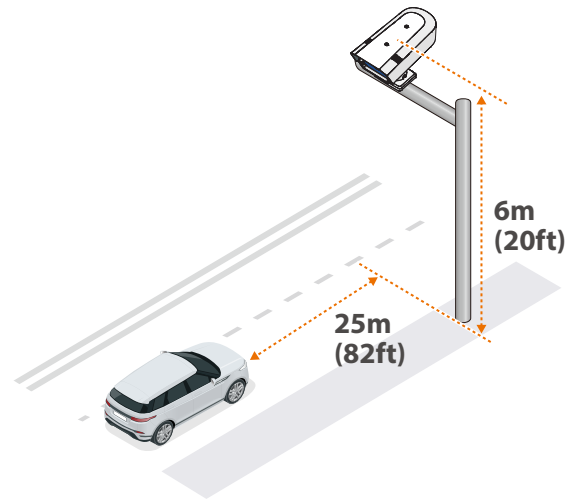

2.2 Overhead and Roadside mounting (Continued)

If overhead mounting is not possible, use roadside mounting. In roadside mounting, the LPR camera is most often mounted on a pole mount on the side of the road. Refer to the previous table for the maximum mounting height and forward distance from lane center for each LPR camera. For better results, choose the shortest target distance for your actual mounting location.

Improper Installation

2m/(7ft) Mounting Height
25m/(82ft) Forward Distance
45° Horizontal Angle

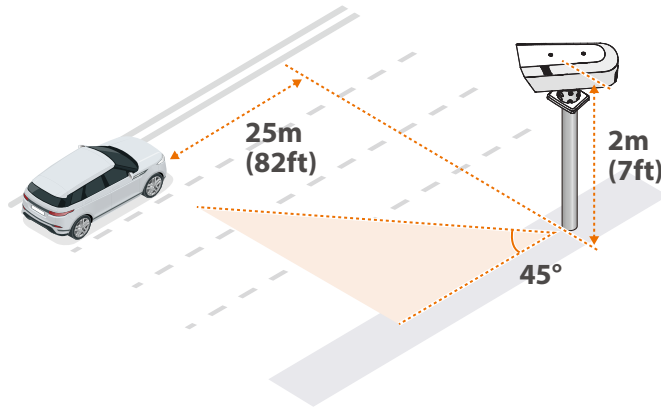

Proper Installation

6m/(20ft) Mounting Height
25m/(82ft) Forward Distance
15° Horizontal Angle

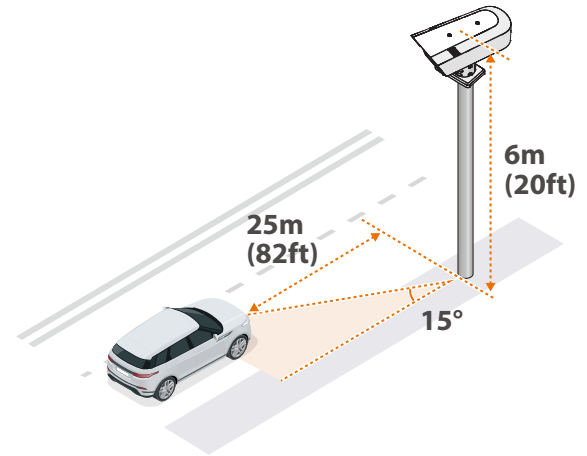

2.3 Vehicle speed and number of lanes covered

RoadAI can support up to two lanes. If you want to recognize more lanes, please install additional **TNO-7180RLP**. The vehicle speed at which the camera can recognize license plates is **up to 200 kmh(125 mph)**.

2.4 Daytime and Nighttime

- **MMCR effect on day/night**

In order to improve the accuracy of MMCR, you need external visual lights to provide sufficient illumination. Reliable MMCR results may not be provided in environments that lack sufficient illumination, such as at night or in an underground parking lot.

- **Accuracy considerations for plate reading in day vs night**

External visible light is required to highlight non-reflective plates when camera is in Black and White mode (mostly in environments with insufficient lighting). Plates should be clearly visible by human on the video footage.

- **Accuracy considerations due to headlight intensity or vehicle from opposite side**

Usually the light from the opposite side is diffused on the sides and not affecting the application performance. However, modern vehicles might have pretty powerful lights and may incur a washed out symbols on the plates which results in losing reading accuracy.

- **Fog/heavy rain/sandstorm definitely decrease the accuracy and detection level**

2.5 Power requirements

PoE or 12V DC can be used as a power source. Power requirements for PoE are 27W typical (50W max.), for 12V DC - 25W typical (47.5W max). PoE and AC/DC power supply are not included, please purchase separately.

2.6 Mounting Options

Road AI Cameras have various accessories such as Wall, Table Top, Horizontal and Hanging mounts.

Wall & Vertical

SBP-187WMW

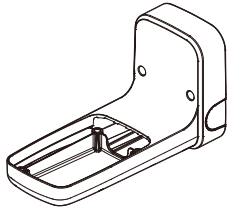
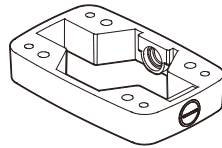
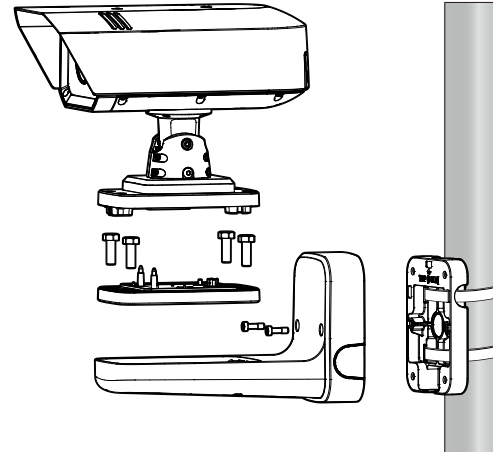

Table Top

SBP-300BW1



Pole Mounting Installation



Horizontal Pole

SBP-300PMW2

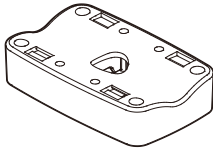

- ◆ SBP-187WMW supports Wall and vertical pole installation. Steel strap sold separately (SBP-1005)
- ◆ SBP-300PMW2 include steel strap

3 INSTALLING AND POSITIONING CAMERA

3.1 Camera Installation

NOTE: Refer to TNO-7180RLP User Manual for a more detailed information.

Installing the camera body

1. Connect the audio/alarm/RS-485/power/network cable to the installation base port.

 For power supply, connect the power cable to the provided terminal block and plug it in the port.

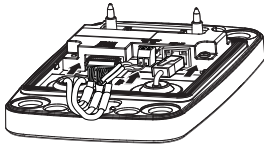

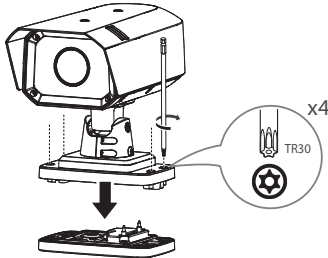

2. Use the provided driver bit to join the camera body to the installation base.

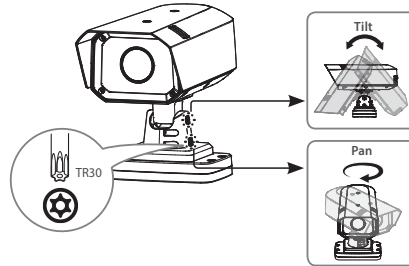

 For assembly, use a torque of at least 10 Nm to tighten the screws.

3. Use the provided driver bit to loosen the camera screws so that you can adjust the surveillance direction. You can adjust pan and tilt of your camera.



-  Force to change the direction without loosening the screws might cause breakage or damage to the product.
- For assembly, use a torque of at least 10 Nm to tighten the screws
- Do not use the screws on the right side.

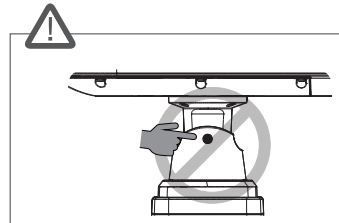

4. Once installation is complete, peel off the protective cover from the camera lens.

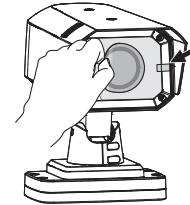

3.2 Adjusting Plate Tilt Angle

For best results, check the angle of your plate compared to the horizontal angle and rotate the camera to less than 5° as shown below.

Recommended Angles

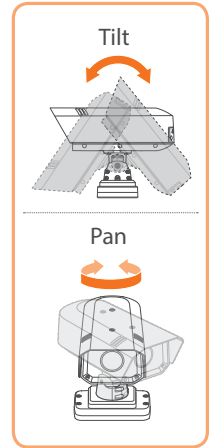
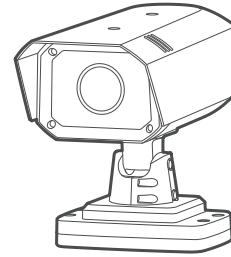
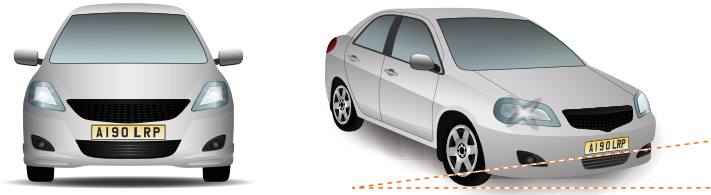

5° max



>5°

NOTE: Refer to the “show plate grid” section available in Road AI settings for assistance

4 CONFIGURING YOUR CAMERA

NOTE: *There is no default username and password to access the camera settings*

- 1) *Please setup your own username and password when you access camera settings for the first time.*
- 2) *Make sure to set correct date and time for the camera before going in to any additional settings.*
- 3) *If camera firmware update is required, it is strongly advised to factory reset the camera to make sure that changes applied successfully*

4.1 Field of View

Follow the steps below on the camera configuration webpage

- ❶ Configure camera so that left and right sides are correct, not mirrored.
- ❷ Set camera zoom to capture license plates
- ❸ Adjust camera view angle so plate passes through the middle of the image.

Configuring Initial Camera Settings

For proper operations, please, check and set properly:

- **LPR setup** (▶ page 15)
- **Camera Date Time** (▶ page 22)
- **IP settings** (▶ page 23)
- **SD card storage** (▶ page 24)
- **Camera exposure and focus** (▶ pages 26~27)

SSDR, WDR, DIS, Defog, AGC and anti-flickering features are good for human eye but affect computer vision performance and therefore setting these to the least possible effect or turning off strongly advised.

4.1 Field of View (Continued)

[LPR setup of Camera]

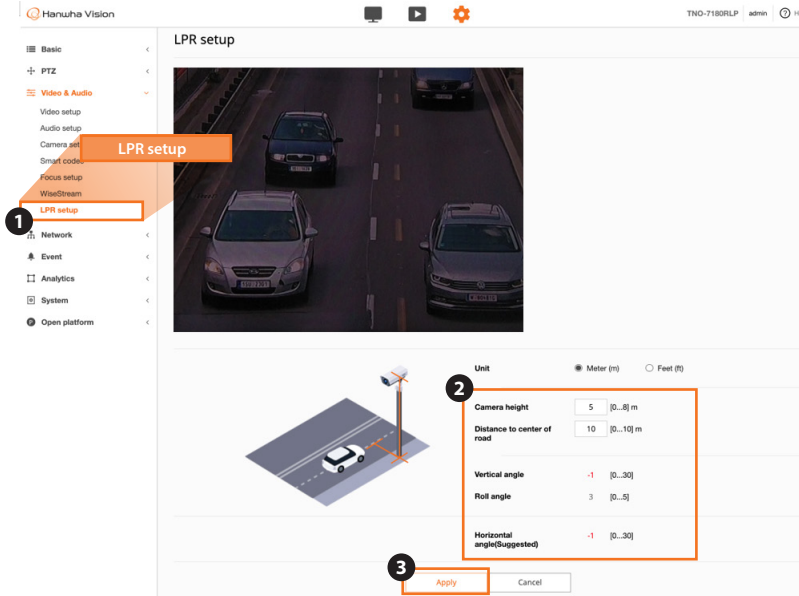

- 1 From the Video & Audio menu, select **LPR setup**.
- 2 Enter a camera height from ground, and a distance between the camera and center of lane when installing an LPR (license plate recognition) camera, the optimal horizontal angle for the camera is suggested by calculating multiple values, which will make installation easier. You can also check the camera's vertical angle, horizontal angle, and roll angle on the web viewer in real time.
- 3 When you complete the configuration, click on the **Apply** button at the bottom of the page

4.1 Field of View (Continued)

[LPR setup of Camera] (Continued)

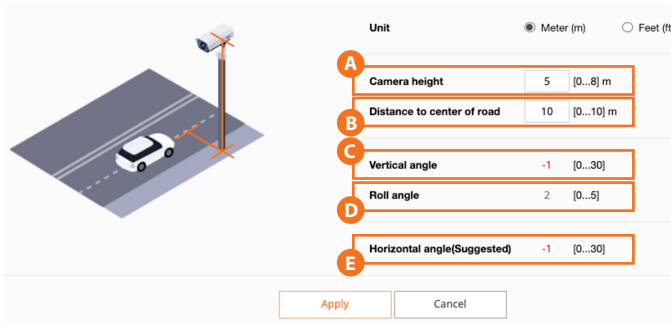

- A** You can enter the height of the camera from the ground. It is recommended to enter accurate values since the **Horizontal angle** is calculated based on the **Camera height** value, **Distance to center of road** value that are entered by the user, and other values.
- B** You can enter the distance from the center of the lane that the camera is recording to the installed camera.
- C** You can check the current vertical angle of the installed camera. In other words, the downward angle of the camera is displayed. If you change the vertical angle of the camera physically, the values change in real time.
- D** You can check the roll angle of the currently installed camera. If you change the roll angle of the camera physically, the values change in real time.
- E** You can check the optimal horizontal angle of the LPR camera that is being installed. In other words, it suggests the optimal horizontal angle of how much the camera should be adjusted from side to side. You can adjust the camera from side to side by following the suggested horizontal angle.
The value is calculated based on the **Camera height** value, **Distance to center of road** value that are entered by the user, and other values.

4.1 Field of View (Continued)

[Setting up RoadAI]

Please go to App in camera open platform section.

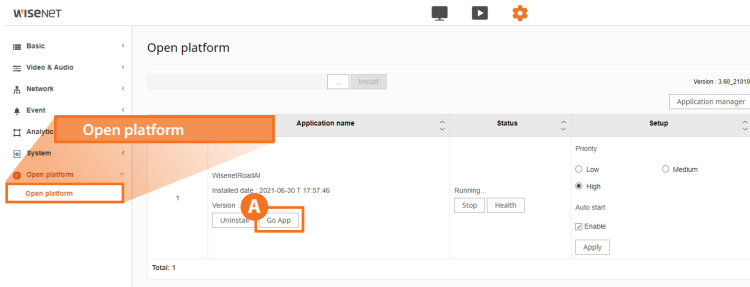

To run the RoadAI app, select the **Open platform** menu and click the **Go App** button in the **Application name** field.

4.1 Field of View (Continued)

[Setting up RoadAI] (Continued)

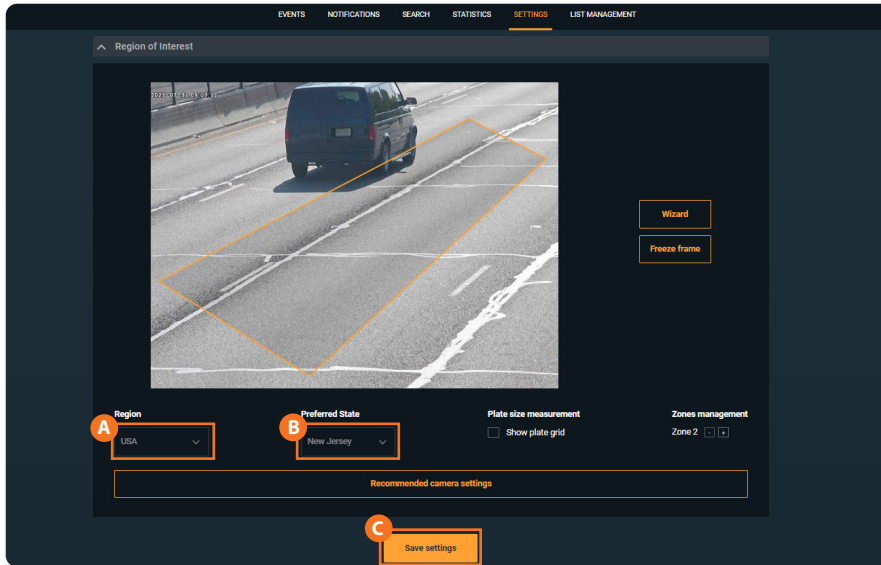

A First, choose the **Region**.

1) Choose the correct region that matches your country/region (Europe is set by default).

2) For Europe/US region specify **B** the **Preferred country/state** to improve the ANPR accuracy.

3) Save the settings. Click **C** **Save settings**. The application will restart for the selected region to take effect. After clicking Reload, wait for several seconds and reload the browser page.

4.1 Field of View (Continued)

[Setting up RoadAI] (Continued)

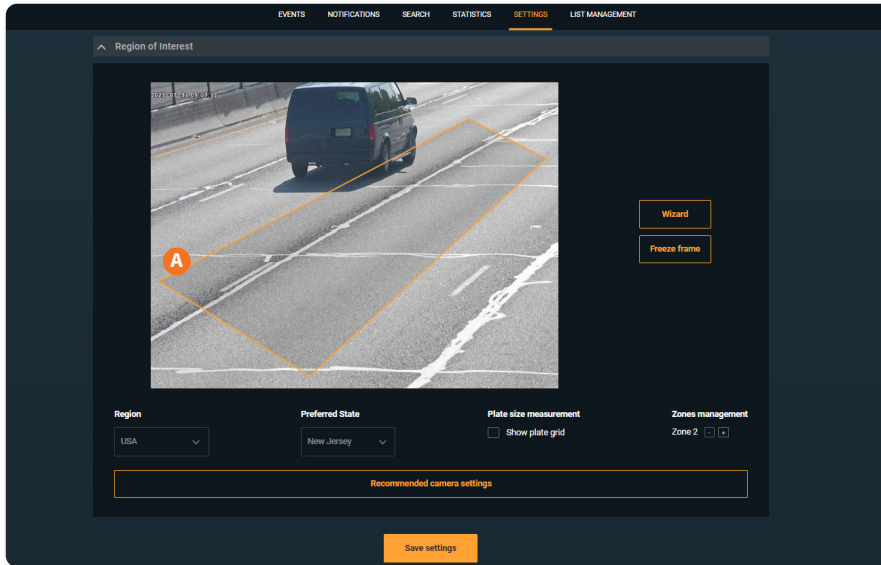

A Set up the Region of Interest (ROI), a zone that frames the recognition zone.

Keep it tight to assure the best performance of the application.

Please set the upper border of **A** the recognition zone further from the edge of the frame. This allows vehicle being fully visible during detection and improves ANPR and MMR performance.

4.1 Field of View (Continued)

[Setting up RoadAI] (Continued)

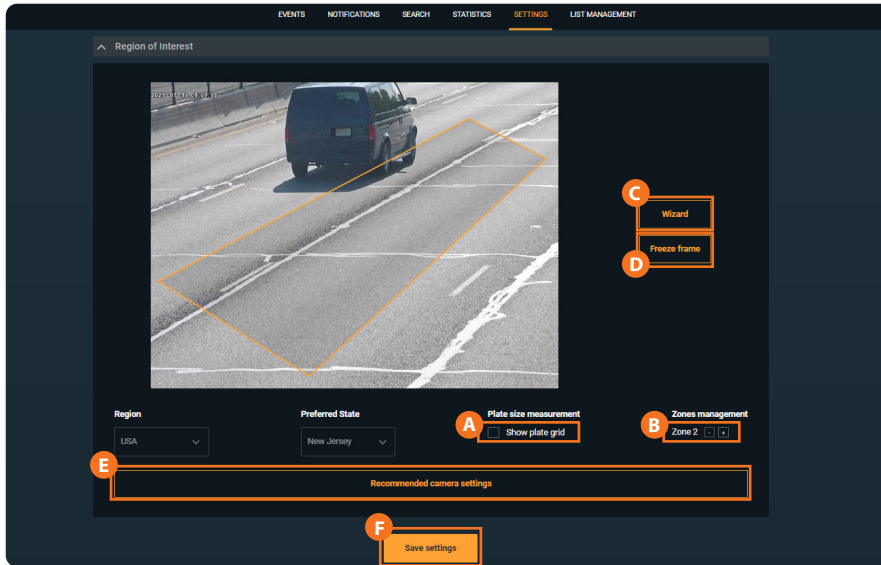

- A** Show/hide the Plate size measurement tool.
- B** Add License Plate Recognition Zone.
- C** Wizard tool.
- D** Freeze frame button.
- E** Apply the **Recommended camera settings**.
- F** Click **Save settings**.

NOTE: The **Recommended camera settings** are a starting point for the camera setup. Please, adjust the settings up to your installation conditions.

Make sure the number plates are well visible both in day and night.

4.1 Field of View (Continued)

[Setting up RoadAI] (Continued)

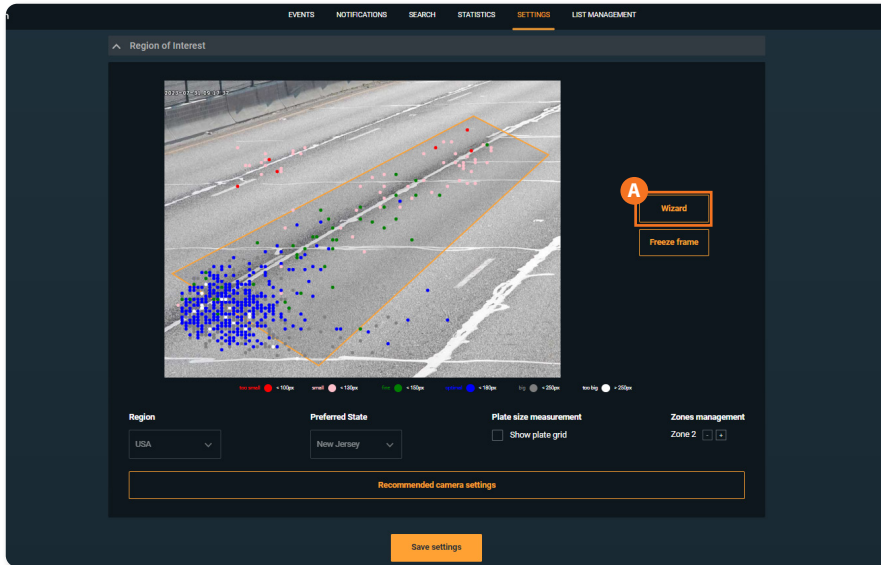

A **Wizard** tool displays the statistic on location and sizes of the latest 1000 recognized plates.

Use it to adjust the camera zoom and the recognition zone.

Try to keep plates in **green** and **blue** range.

At least **100** plates should be registered to display the data.

NOTE: Camera trying to capture every plate visible. However, errors during setup might result in multiple detection of the same plate with correct or even mistaken reads. Please, follow the installation recommendations and guide for plates size in the area of recognition.

Please use Wizard and Plate Grid tools to check whether the plates are of the proper size. Adjust the ROI, camera zoom or camera position to keep plates within recommended size range. This will increase the accuracy and reduce the chance of double detection.

4.2 Configure Initial Camera Settings

[Date and Time]

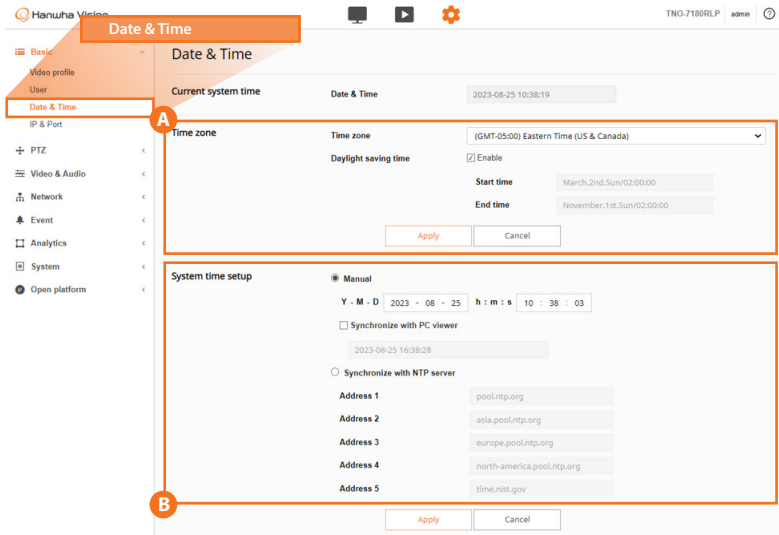

Choose **A** **Timezone** and set **Use daylight saving time** if applicable.

Set **B** date and time or opt to synchronizing with your PC or NTP server.

NOTE: Road AI app relies on camera time and time zone settings and if those are not set properly, you may not see events in Road AI app and events delivered to the outer systems may not have proper timestamps.

4.2 Configure Initial Camera Settings (Continued)

[Network Settings]

The screenshot shows the 'IP & Port' configuration page in the Hanuwa Vision web interface. The left sidebar contains a menu with options: Basic, Video profile, User, Date & Time, IP & Port (highlighted), PTZ, Video & Audio, Network, Event, Analytics, System, and Open platform. The main content area is divided into 'IP address' and 'Port' tabs. The 'IP address' tab is active, showing two sections: 'IPv4 setup' and 'IPv6 setup'. The 'IPv4 setup' section is highlighted with an orange border and contains the following fields:

IPv4 setup	
IP type	Manual
MAC address	00:09:18:6A:F2:48
IP address	10.101.1.2
Subnet mask	255.255.255.0
Gateway	10.101.1.1
DNS 1	8.8.8.8
DNS 2	8.8.4.4
Host name	TNO-7180RLP-0009186AF248
MTU	1500 (1280 - 1500)

The 'IPv6 setup' section is located below the IPv4 setup and contains the following fields:

IPv6 setup	
IPv6	<input type="checkbox"/> Enable
IP type	Default
IP address	
Prefix	64

At the bottom of the configuration area, there are 'Apply' and 'Cancel' buttons.

Proper IP, DNS and ports setting are important for:

- NVR and other integrations
- outside LAN access if required

NOTE: *Reboot the camera whenever IP address gets changed.*

4.2 Configure Initial Camera Settings (Continued)

[microSD card]

Micro SD card needs to be set up correctly for the application to access it and store images

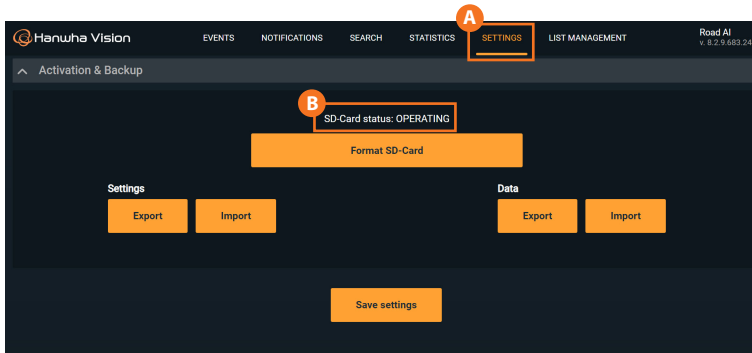

SD-card is managed by the RoadAI application and no user interaction needed.

Please check the **B** SD-Card status in the **SETTINGS** section of the RoadAI app. **A**

Change the micro SD card if you see Error status.

4.2 Configure Initial Camera Settings (Continued)

[Analytics]

Make sure all analytics is disabled

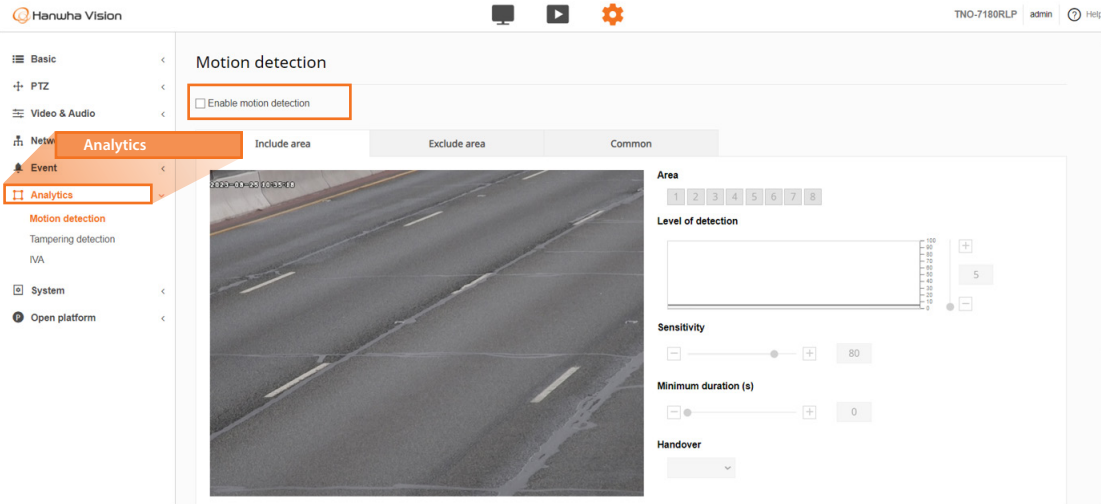

4.2 Configure Initial Camera Settings (Continued)

[Exposure adjustments]

The recommended settings from the ParkWatch application are the starting point for the camera setup, and cover most cases. Adjust the settings up to your installation conditions. Make sure the number plates are well visible both in day and night.

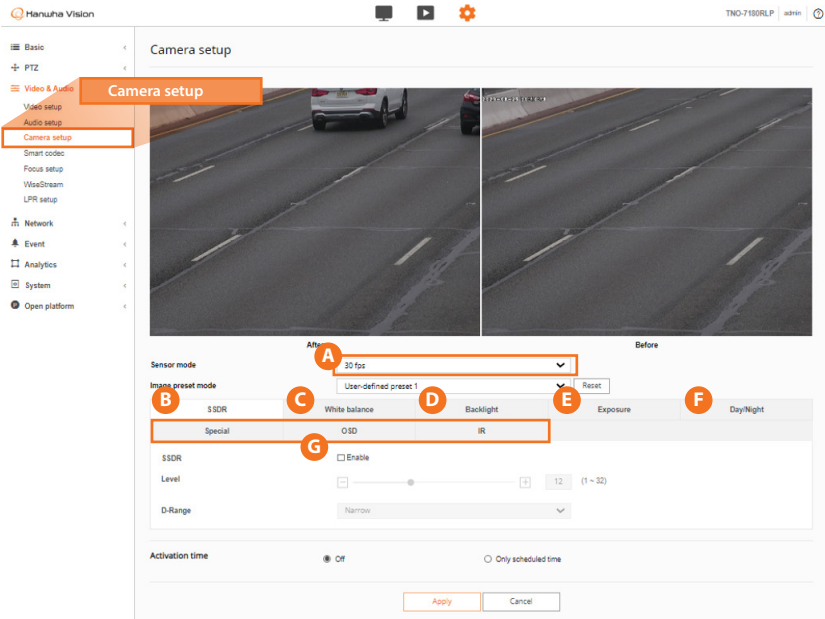

- A** Sensor: 25-30 fps
- B** SSSR: Off
- C** White balance: ATW
- D** Backlight: Off
(try other backlight options only if camera gets blinded by headlights in the night)
- E** Exposure:
 - minimum shutter speed : 1/1000
 - maximum shutter speed : 1/12000
 - preferred shutter speed : 1/1500
 - Anti flicker : Off
 - SSNR : Off
 - AGC : Manual
 - Iris mode: Manual
 - Iris: F3.4
- F** Day/Night:
 - Mode: Auto
- G** IR:
 - Auto 1 for long distance
 - Auto 2 for close installation
 - Other settings: default

4.2 Configure Initial Camera Settings (Continued)

[Exposure adjustments-Automatic Gain Control]

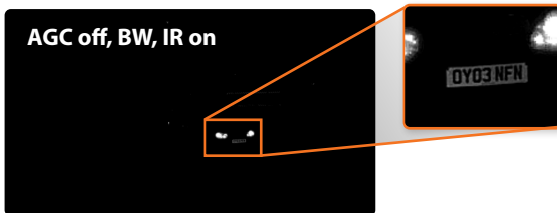
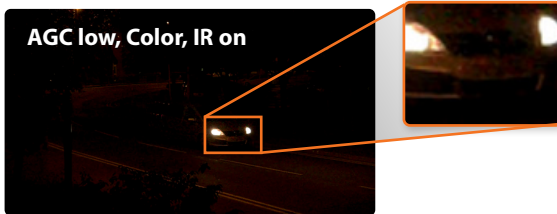

Automatic Gain Control can improve overall scene visibility notably. However, even at low setting AGC produces noise that can ruin license plate images, also lighter areas tend to bleach out. See illustrations to the left.

Start with turning AGC off. See the illustration to the left. Set AGC to low to improve plates visibility unless only other methods are helpful.

Adjust zoom so that real plate pixel width is at least 130px. Consider adjusting recognition zone to be closer to the centre of the frame to avoid the IR vignette effect.

NOTE: Do not use WDR as it decreases the shutter speed and may lead to the blur of the vehicles on footage.

4.3 Focus

A unique feature of this camera allows you to select the plate area and hit a button to perform a “Simple Focus” on this plate area.

- 1 From the Video & Audio menu, select **Focus setup**.
- 2 Click and drag to draw an area of focus where the license plate is displayed.
- 3 Click the **Simple Focus** button to initiate a focus operation on the user-specified area.

NOTE:

The area indicated is not stored. If you need to perform a new Simple Focus, please draw a new area on-screen

Set the focus to have plates in the proper pixel size.

- 130-300 pixels for regular EU plates
- 80-300 pixels for US plates without stacked symbols (small ones)
- 160-300 pixels for US plates with stacked symbols

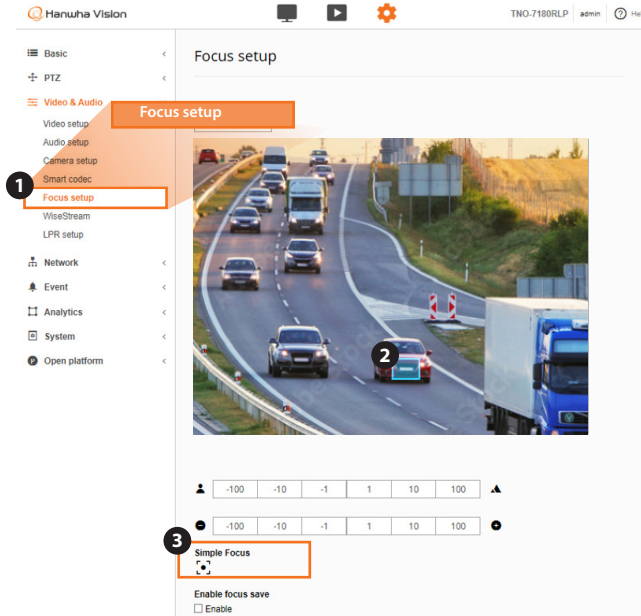

4.4 Pixel width of License/Number plate

- 1 Spread or move license/number plate (vehicles) across the scene and take snapshots using web viewer capturing feature (**Live → Capture**);

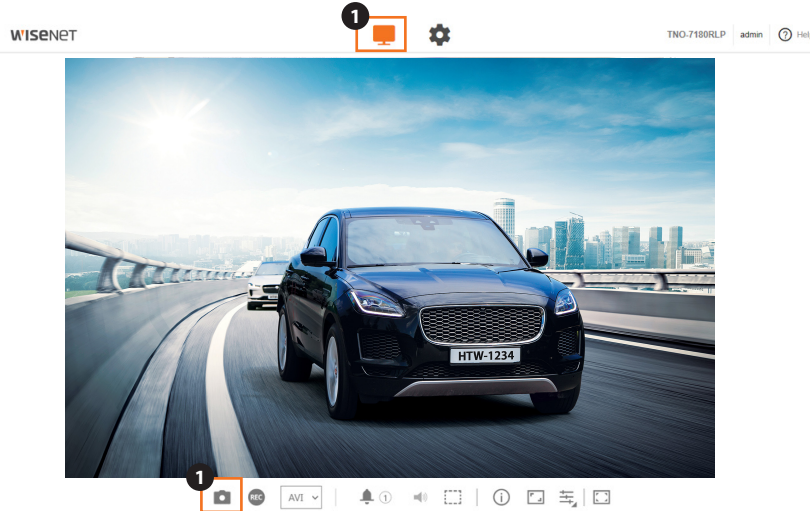

4.4 Pixel width of License/Number plate (Continued)

Check pixel width of the plate.

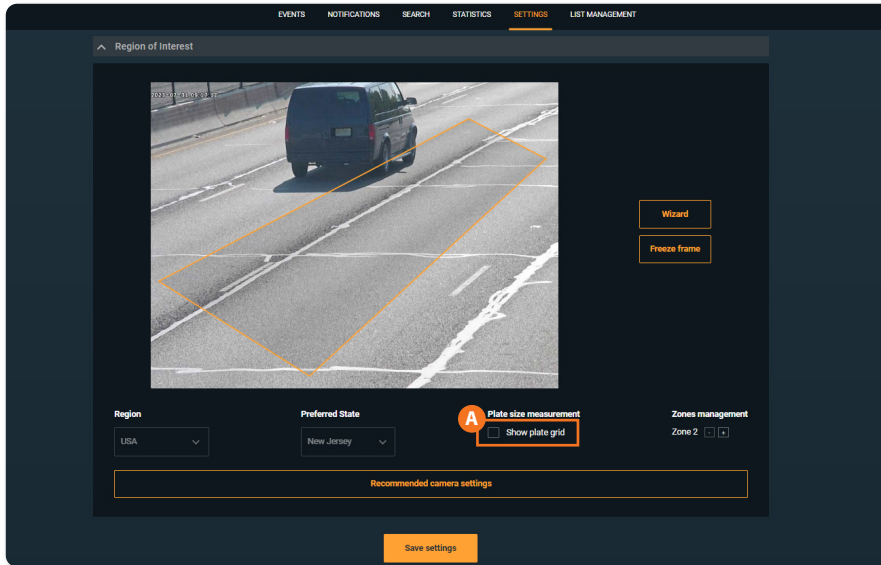

Use **A** **Plate Grid** tool in the **Settings** tab of ParkWatch and **Freeze Frame** feature to check whether plate fits the required range.

4.5 Observing PROPER Installation

SCENE REQUIREMENTS:



License/number plate is more than 130 px in width



License/number plate is readable

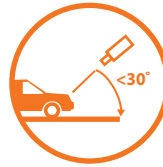

Vertical angle is less than 30°



Tilt angle is less than 5°

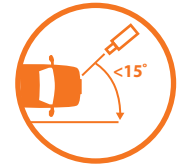

Horizontal angle is less than 30°

Fig. 1
Daytime



- good proportion to the frame width
- well illuminated
- sufficient contrast
- acceptable tilt angle

Fig. 2
Night time



- good proportion to the frame width
- perfect IR power
- sufficient contrast
- critical yet acceptable tilt angle

4.5 Observing PROPER Installation (Continued)

POSSIBLE IR RESTRICTIONS:



The license/number plate is quite close to the frame boundary.
You may notice a vignette effect.

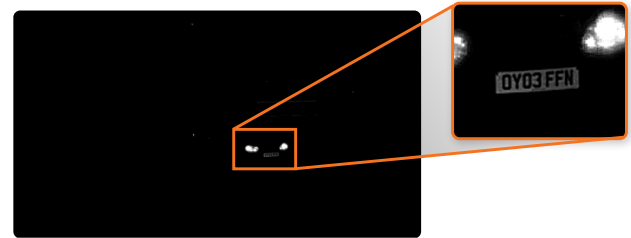

The license/number plate is closer to the centre of the frame.
The plate is illuminated much better.

Pay special attention to IR vignette effect (see illustration on the left) when setting up recognition zone. The closer to the center the more even illumination is.

Also, in this particular case the real pixel width of the license/number plate is critically small.

The Automatic Gain Control effect will be illustrated in camera exposure settings section.

4.5 Observing PROPER Installation (Continued)



Too small (less than 130px wide) Tilt angle exceeds 5°

Focus and Shutter faults



Depth of field is insufficient to cover foreground license plates. Adjust the lens settings.



Improper focus settings. Adjust the lens.



Blurry image due to long exposure. Fix the shutter speed to obtain a sharper picture.

4.5 Observing PROPER Installation (Continued)

Exposure faults



Too much light. Either adjust the iris or shutter speed.
 Night time: dim the IR or set the AGC to Low.



Insufficient light. Adjust exposure settings or provide additional lighting.

5 CAMERA SPECIFICATION

Video	
Imaging Device	1/1.8" 3MP CMOS
Resolution	3M: 2048x1536, 1920x1080, 1280x1024, 1280x960, 1280x720, 1024x768, 800x600, 800x448, 720x576, 720x480, 640x480, 640x360, 320x240 2M: 1920x1080, 1280x1024, 1280x960, 1280x720, 1024x768, 800x600, 800x448, 720x576, 720x480, 640x480, 640x360, 320x240
Max. Framerate	3M: H.265/H.264: Max. 55fps/50fps(55Hz/50Hz), MJPEG: Max. 5fps(55Hz/50Hz) 2M: H.265/H.264: Max. 60fps/50fps(60Hz/50Hz), MJPEG: Max. 5fps (60Hz/50Hz)
Min. Illumination	Color 0.1 Lux (1/30sec, gain 48dB)
Video Out	CVBS: 1.0 Vp-p / 75Ω composite, 720x480(N), 720x576(P) for installation USB: Micro USB Type B, 1280x720 for installation

Lens	
Focal Length (Zoom Ratio)	6.8~120mm(18x) motorized varifocal
Max. Aperture Ratio	F1.6(Wide)~F4.13(Tele)
Angular Field of View	H: 54.5°(Wide)~3.4°(Tele)/V: 42.3°(Wide)~2.5°(Tele)
Min. Object Distance	2m
Focus Control	Simple focus, Focus save
Lens Type	DC auto iris
Mount Type	Board in type

Pan / Tilt / Rotate	
Operational	
Camera Title	Displayed up to 85 characters
Day & Night	Auto(ICR)
Backlight Compensation	BLC, SSSDR
Digital Noise Reduction	SSNRV
Digital Image Stabilization	Not Support
Defog	Not Support
Motion Detection	8ea, polygonal zones
Privacy Masking	6ea, Rectangle zones - Color: Grey/Green/Red/Blue/Black/White
Gain Control	Support
White Balance	ATW / AWC / Manual / Indoor / Outdoor
LDC	Not Support
Electronic Shutter Speed	Minimum / Maximum / Anti flicker (1/25 ~ 1/12,000sec) / Double shutter mode
Video Rotation	Flip, Mirror
Analytics	Directional detection, Motion detection, Appear/ Disappear, Enter/Exit, Loitering, Tampering, Virtual line
Serial Interface	RS-485/422(Samsung-T, Pelco-D/P, Panasonic, Bosch, AD, GE, Vicon, Honeywell)

Alarm I/O	Configurable 4 Port
Alarm Triggers	Analytics, Network disconnect, Alarm input
Alarm Events	File upload via FTP and e-mail Notification via e-mail NAS recording at event triggers Alarm output
Audio In	Selectable(mic in/line in) Supply voltage: 2.5VDC(4mA), Input impedance: 2K Ohm
Audio Out	Line out, Max.output level: 1Vrms
IR Viewable Length	50m

Radiometry

Network

Ethernet	RJ-45(10/100/1000BASE-T)
Video Compression	H.265/H.264: Main/Baseline/High, MJPEG
Smart Codec	Manual(5ea area), WiseStream II
Bitrate Control	H.264/H.265: CBR or VBR MJPEG: VBR
Streaming	Unicast(20 users) / Multicast Multiple streaming (Up to 10 profiles)
Protocol	IPv4, IPv6, TCP/IP, UDP/IP, RTP(UDP), RTP(TCP), RTCP,RTSP, NTP, HTTP, HTTPS, SSL/TLS, DHCP, FTP, SMTP, ICMP, IGMP, SNMPv1/v2c/v3(MIB-2), ARP, DNS, DDNS, QoS, PIM-SM, UPnP, Bonjour, LLDP, SRTP

Security	HTTPS(SSL) Login Authentication Digest Login Authentication IP Address Filtering User access log 802.1X Authentication(EAP-TLS, EAP-LEAP) Device Certificate(Hanwha Techwin root CA) Secue boot TPM
Application Programming Interface	ONVIF Profile S/G/T SUNAPI(HTTP API) Open platform v3.60

General

Webpage Language	English, Korean, Chinese, French, Italian, Spanish, German, Japanese, Russian, Swedish,, Portuguese, Czech, Polish, Turkish, Dutch, Hungarian, Greek
Web Viewer	Supported OS: Windows 7, 8.1, 10, Mac OS X 10.10, 10.11, 10.12 Recommended Browser: Google Chrome Supported Browser: MS Explore11, MS Edge, Mozilla Firefox(Window 64bit only), Apple Safari(Mac OS X only)
Edge Storage	Micro SD/SDHC/SDXC 1slot (256GB)
Memory	2048MB RAM, 256MB Flash

Environmental & Electrical

Operating Temperature / Humidity	Normal : -40°C~-+55°C(-40°F ~ +131°F) / Intermittent : -40°C~-+60°C(-40°F ~ +140°F) Cold start : -40°C Maximum Temperature based on NEMA-TS 2(2.2.7) : +74°C(+165°F) Less than 95% RH(Non-condensing)
----------------------------------	--

Storage Temperature / Humidity	-50°C~+60°C / Less than 95% RH(Non-dondensing)
Certification	IP66, IK10, NEMA 4X, NEMA TS 2(2.2.8, 2.2.9)
Input Voltage	HPoE, 12VDC
Power Consumption	PoE : Max 50W, Typical 27W 12VDC : Max 47.5W, Typical 25W

Mechanical

Color / Material	White
RAL Code	RAL9003
Product Dimensions / Weight	W186.9 x D293.7 x H259.3 (mm) / 4.8kg

Road AI LPR/ANPR/MMCR		
Solution	City Traffic Observation	Highways
Speed Description	Regular Speed	High Speed
Lane Coverage	Up to 2 lanes	Up to 2 lanes
Speed limit	Up to 120kmh (75mph)	Up to 200kmh (125mph)
Min. Forward Distance	16m (52ft)	27m (90ft)
Max. Forward Distance	46m (150ft)	46m (150ft)
Max. Horizontal Angle	25°	15°
Max. Vertical Angle	25°	15°
Horizontal Offset	Up to 7m (24ft)	Up to 4m (12ft)
Camera Height	Up to 12m (39ft)	Up to 12m (39ft)
Vehicle Recognition	Make : 70+ Model : 600+ Color : 11	Make : 70+ Model : 600+ Color : 11

NOTE: for the US version, lane coverage is up to one lane and the speed limit is up to 100 mph for the high-speed highway solution.

For more information visit us at

www.HanwhaVision.com



Head Office

6, Pangyo-ro 319beon-gil, Bundang-gu, Seongnam-si,
Gyeonggi-do, 463-400 Rep. of KOREA

Tel : +82.70.7147.8753

Fax : +82.31.8018.3740

<https://www.HanwhaVision.com>

© 2023 Hanwha Vision Co., Ltd. All rights reserved.

DESIGN AND SPECIFICATIONS ARE SUBJECT TO CHANGE WITHOUT NOTICE

Under no circumstances, this document shall be reproduced, distributed or changed, partially or wholly, without formal authorization of Hanwha Vision Co.,Ltd.