

Small PoE WL LED Illuminator

The Clarius[®] PLUS range of high performance White-Light illuminators are designed to provide class leading performance, long life and ultra low maintenance.

Incorporating the latest surface mount LED's with enhanced optical output and outstanding reliability, they deliver excellent night-time images.

Each unit is fitted with integrated control circuitry to carefully control LED output, delivering consistent illumination and projected working life in excess of 10 years.

The Clarius[®] PLUS range of illuminators includes a new interchangeable lens diffuser system; which allows the user to quickly and easily alter the angle of illumination. Elliptical beam profiles allow more light to be delivered where it is needed, allowing both longer distances and minimising light wastage. The system also helps to prevent overexposure of foreground objects.

As standard the illuminator includes interchangeable lensing to deliver 10° circular, 30°, 60° & 95° elliptical beam profiles.

PRODUCT CODE

SECL-WL928-POE-S

Small Clarius PLUS PoE White-Light Illuminator

Interchangeable Diffuser Lens



FEATURES

WL Illuminator designed to provide dedicated lighting for IP cameras via PoE (power over ethernet)
IEEE802af compliant
Latest SMT LED technology
Elliptical beam profiles
Distances up to 68m (223')
Angle 10°, 30°, 60° & 95°
5 year warranty
IP66 weather proof rating
Built-in photocell WL on/off
Photocell following contact
Telemetry input for remote switching
CleanLITE [®] self cleaning lens coating technology
Pressure equalisation vent
High quality anodised aluminium heatsink

SPECIFICATIONS



Product Code	Angle	Distance		FOV	
SECL-WL928 -POE-S	10° - Circular	68m	223'	12m	39'
	30° - Elliptical	40m	130'	21m	70'
	60° - Elliptical	28m	93'	33m	107'
	95° - Elliptical	17m	56'	37m	122'

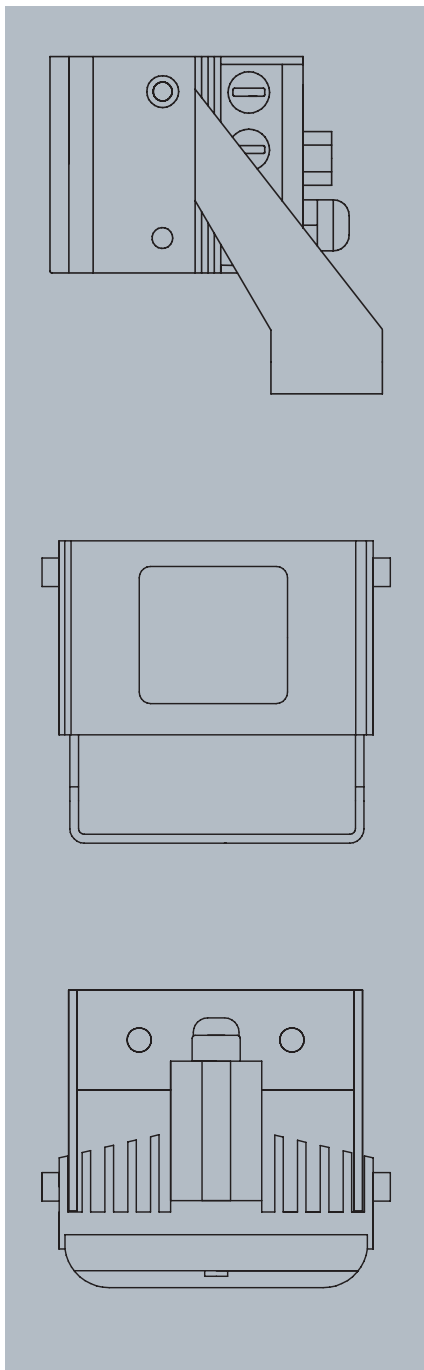

GENERAL

ELECTRONICS	High efficiency surface mount high power LED's with advanced current limited integral control circuitry
CONSTRUCTION	Robust high quality aluminium extrusion
FRONT WINDOW	Polycarbonate high transmission protective (vandal proof) ir filter with CleanLITE® technology
FINISH	Black anodised
POWER CABLE	3m including RJ45 connector
INTERFACE CONNECTOR	Photocell Following Contact & Remote Telemetry Input
PRESSURE EQUALISATION VENT	Prevents thermal expansion & pressure cycling
PHOTOCELL	Adjustable 20 -70 Lux
ILLUMINATION	Adjustable 10% - 100%
OPERATING TEMPERATURE	-50° to 50°C (-58° to 122°F)
WEIGHT	750g (1.6lbs)
MOUNT	Powder coated stainless steel wall mount
DIMENSIONS	68 x 110 x 78mm (2.68" x 4.33" x 3.07")

ELECTRICAL

POWER OVER ETHERNET	IEEE802.3af Compliant
CONSUMPTION	12W

LIGHTING OUTPUT

LUMEN OUTPUT	928lm
WAVELENGTH	Visible spectrum (400-750nm)
COLOUR TEMPERATURE	6500k
COLOUR RENDERING INDEX	74-80+

CERTIFICATIONS

WEEE	Waste electrical & electronic equipment european directive 202/96/EC	
RoHS	Restriction of hazardous substance european directive 202/95/EC	
CE-EMC	EN61000, FCC Part 15. 107 15. 108 Class B	
SAFETY	EN60598:2004 EN60825-1	Electrical Safety Laser Eye Safety
IP	IP66 In Accordance With EN60529:1992	