

Swing Turnstile (X)

User's Manual







Foreword

General

This manual introduces the functions and operations of the swing turnstile.

Safety Instructions

The following categorized signal words with defined meaning might appear in the manual.

| Signal Words | Meaning |
|--|---|
|  DANGER | Indicates a high potential hazard which, if not avoided, will result in death or serious injury. |
|  WARNING | Indicates a medium or low potential hazard which, if not avoided, could result in slight or moderate injury. |
|  CAUTION | Indicates a potential risk which, if not avoided, could result in property damage, data loss, lower performance, or unpredictable result. |
|  TIPS | Provides methods to help you solve a problem or save you time. |
|  NOTE | Provides additional information as the emphasis and supplement to the text. |

Revision History

| Version | Revision Content | Release Time |
|---------|---|---------------|
| V1.0.3 | Updated the manual. | December 2022 |
| V1.0.2 | Remove battery information in Inner Components chapter. | May 2020 |
| V1.0.1 | Add an electrical safety note. | April 2020 |
| V1.0.0 | First release. | March 2020 |

About the Manual

- The manual is for reference only. If there is inconsistency between the manual and the actual product, the actual product shall prevail.
- We are not liable for any loss caused by the operations that do not comply with the manual.
- The manual would be updated according to the latest laws and regulations of related regions. For detailed information, see the paper manual, CD-ROM, QR code or our official website. If there is inconsistency between paper manual and the electronic version, the electronic version shall prevail.
- All the designs and software are subject to change without prior written notice. The product updates might cause some differences between the actual product and the manual. Please contact the customer service for the latest program and supplementary documentation.

- There still might be deviation in technical data, functions and operations description, or errors in print. If there is any doubt or dispute, please refer to our final explanation.
- Upgrade the reader software or try other mainstream reader software if the manual (in PDF format) cannot be opened.
- All trademarks, registered trademarks and the company names in the manual are the properties of their respective owners.
- Please visit our website, contact the supplier or customer service if there is any problem occurred when using the device.
- If there is any uncertainty or controversy, please refer to our final explanation.

Important Safeguards and Warnings

This chapter describes the contents covering proper handling of the turnstile, hazard prevention, and prevention of property damage. Read these contents carefully before using the turnstile, comply with them when using, and keep them well for future reference.



WARNING

- Expectant mother, the elderly, and children must pass the turnstile under guard.
- If children shorter than 1 meter need to pass the turnstile, they need to be scooped by adults.
- Make sure that the system protection GND is correctly connected to prevent human injury.
- Do not use the turnstile when thunder occurs; otherwise the turnstile might be damaged.



- After the installation, remove the protective film and clean the cabinet.
- Maintain the turnstile regularly to ensure that the turnstile can work normally.
- If the turnstile is installed near places like swimming pool entrance, 50 km near the seaside, construction sites, and more, the stainless cabinet must be maintained more frequently.
- Do not use painting diluent or organic agent during maintenance.
- After the construction is completed, hand over the turnstile key to professional maintenance personnel.

Operation Requirements

- Do not place or install the turnstile in a place exposed to sunlight or near the heat source.
- Keep the turnstile away from dampness, dust or soot.
- Keep the turnstile installed horizontally on the stable place to prevent it from falling.
- Do not drop or splash liquid onto the turnstile, and make sure that there is no object filled with liquid on the turnstile to prevent liquid from flowing into the turnstile.
- Install the turnstile in a well-ventilated place, and do not block the ventilation of the turnstile.
- Operate the turnstile within the rated range of power input and output.
- Do not disassemble the turnstile.
- Transport, use and store the turnstile under the allowed humidity and temperature conditions.

Electrical Safety

- Improper battery use might result in fire, explosion, or inflammation.
- When replacing battery, make sure that the same model is used.
- Use the recommended power cables in the region and conform to the rated power specification.
- Use the power adapter provided with the turnstile; otherwise, it might result in people injury and device damage.

- The power source shall conform to the requirement of the Safety Extra Low Voltage (SELV) standard, and supply power with rated voltage which conforms to Limited power Source requirement according to IEC60950-1. Please note that the power supply requirement is subject to the device label.
- Connect the device (I-type structure) to the power socket with protective earthing.
- The appliance coupler is a disconnection device. When using the coupler, keep the angle for easy operation.
- The external power cable shall meet the working temperature at least 75°C.

Precautions for Use

- When authorizing to pass the turnstile, there should be no person on the opposite side of the turnstile, otherwise the barriers will unlock until the person on the opposite side exits.
- Pass the turnstile as soon as possible after authorization. If the passager does not enter within the specified time, the system will automatically close the barriers.
- When multiple person entering, passagers can pass with continuous authorization when memory mode is enabled. But the interval between continuous authorizations is recommended to be 2 s–5 s.
- Pay attention to the status of the turnstile indicator before entering. Green indicates that the turnstile is allowed to pass, and red indicates that the turnstile is not allowed to pass.
- Pay attention to the status of the turnstile indicator when verifying identity. Blue indicates no identity verification; green indicates that the identity verification succeeds and pass is allowed; red indicates that the identity verification fails and pass is not allowed.
- Do not try to forcibly pass through the turnstile. This turnstile supports intelligent anti-trailing function and anti-reverse intrusion function. If you break in forcibly, the system will lock the turnstile, which may cause injury to personnel.
- The authorized card cannot be used with other cards, or the turnstile cannot correctly identify the authorized card.
- Keep the authorized card in a safe place to avoid damaging and causing the identity verification failure.
- When passing through the turnstile, try to avoid blocking the black acrylic strips on both sides of the turnstile by the carry-on items to avoid system misjudgment.
- If you need to move goods, do not use this turnstile to avoid misjudgment of unauthorized entry by the system.

Table of Contents

| | |
|--|------------|
| Foreword | I |
| Important Safeguards and Warnings | III |
| 1 Overview | 1 |
| 1.1 Introduction | 1 |
| 1.2 Product Descriptions | 1 |
| 1.3 Features | 1 |
| 1.4 Passage Control Mode | 2 |
| 2 Application | 4 |
| 3 Structure | 5 |
| 3.1 Appearance | 5 |
| 3.2 Dimensions | 6 |
| 3.3 Inner Components | 6 |
| 4 Installation | 8 |
| 4.1 Safety Instructions | 8 |
| 4.2 Before Installation | 8 |
| 4.2.1 Tools | 9 |
| 4.2.2 Cable Connection | 9 |
| 4.2.3 Cable Layout Diagram | 11 |
| 4.3 Installation Procedure | 12 |
| 4.3.1 Drilling Holes | 12 |
| 4.3.2 Adjusting Turnstile Position | 14 |
| 4.3.3 Fixing Turnstiles | 19 |
| 4.3.4 Installing Swing Barriers | 19 |
| 5 Cable Connection | 21 |
| 5.1 Turnstile Control Panel Port Description | 21 |
| 5.2 Access Controller (Two-Way Card Unlock) | 22 |
| 5.3 Face Recognition Terminal of ASI7/8 Series (One-way Face Unlock & Two-way Card Unlock) | 23 |
| 5.4 Face Recognition Terminal of ASI7/8 Series (Two-way Face Unlock & Two-way Card Unlock) | 24 |
| 6 Configuration and Commissioning | 25 |
| 6.1 Display Operation | 25 |
| 6.1.2 Working Mode | 25 |
| 6.1.3 Passage Control Mode | 26 |
| 6.1.4 Passing Duration Settings | 26 |
| 6.1.5 Lock Delay Settings | 26 |
| 6.1.6 Security Level Settings | 27 |
| 6.1.7 Second Unlock Settings | 27 |
| 6.1.8 Memory Mode Settings | 27 |
| 6.1.9 Unlock and Lock Speed Settings | 28 |
| 6.1.10 Volume Settings | 28 |
| 6.1.11 Unlock Settings After Power-off | 28 |
| 6.1.12 Start Mode | 29 |
| 6.1.13 Origin Settings | 29 |
| 6.1.14 Passage Width Settings | 29 |

| | |
|---|-----------|
| 6.1.15 System Information | 30 |
| 6.1.16 Language | 30 |
| 6.2 Power-On Test..... | 30 |
| 6.3 IR Light and Light Curtain Anomaly Determination..... | 31 |
| 7 FAQ | 33 |
| Appendix 1 Maintenance | 34 |
| Appendix 2 Maintenance of the Stainless Cabinet Surface..... | 35 |
| Appendix 2.1 Rust Protection and Adhesive Failure | 35 |
| Appendix 2.2 Removing Dirt and Rust | 35 |
| Appendix 2.3 Precautions | 36 |
| Appendix 3 Cybersecurity Recommendations | 37 |

1 Overview

1.1 Introduction

Human passage turnstile (hereinafter referred to as the “turnstile”) controls human passages of places like railway stations, factories, tourist resorts, libraries, and more.

1.2 Product Descriptions

3 versions of the turnstile are available.

Table 1-1 Product version description

| Version | Description |
|---|--|
| Card unlock | Unlock with card to enter and exit from a place; an IC card reader and a face recognition access controller are provided. |
| One-way face unlock & two-way card unlock | Unlock with face or card to enter a place, unlock with card to exit from a place; an IC card reader and a face recognition access controller are provided. |
| Two-way face unlock & two-way card unlock | Unlock with face or card to enter and exit from a place; an IC card reader and two face recognition access controllers are provided. |

1.3 Features

- Human-machine interactive parameter configuration.
- Barriers will be closed automatically if no one entered the turnstile after the identity is verified.
- Parameters can be restored to default settings.
- The lock and unlock of barriers can be controlled by remote controller (not provided).
- Two working modes: Normally open mode and normally closed mode.
- Four types of security settings.
- When receiving fire alarm signals, the turnstile will be normally open; and the turnstile can output alarm signals.
- Mechanical anti-pinch and IR anti-pinch.
- Anti-collision: The barriers cannot be broken even if they are violently kicked.
- Unlock and lock speed, pass duration, and lock delay duration are adjustable.
- Second unlock: If a person tries to pass the turnstile without identity verification, alarms will be triggered; if the person stays there and get the identity verified, the barriers will be unlocked.
- Continuous identity verification: If identities of several people (255 people at most) have been verified continuously, these people can pass the turnstile continuously.
- The turnstile can judge unlock directions. You can only enter or exit from a place from where you swipe the card; otherwise the barrier will be locked until the person leaves the turnstile.

- Support intrusion alarm (entering and exiting), stay overtime alarm, trailing alarm, climbing turnstile alarm, unlock anomaly alarm, and more; when alarms are triggered, the indicator light will flash in red.
- Nine passing modes: Authenticated entering and exiting, authenticated entering and free exiting, authenticated entering and no exiting, free entering and authenticated exiting, free entering and exiting, free entering and no exiting, no entering and authenticated exiting, no entering and free exiting, and no entering and exiting.

1.4 Passage Control Mode

Three Passage Control Modes

- Users can unlock and pass the turnstile after swiping cards or verifying face.
- Users can pass the turnstile without identity verification (the IR sensor detects human and then unlock the turnstile).
- All users are not allowed to pass the turnstile.

Figure 1-1 Passage control mode

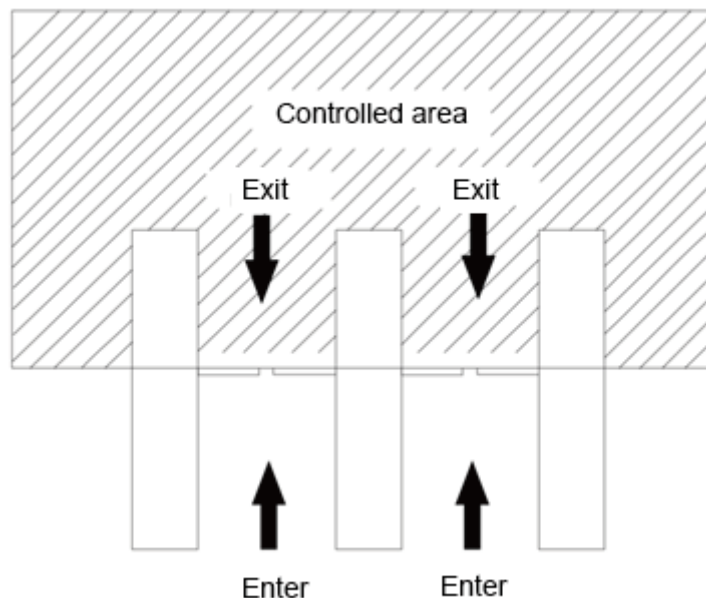

Nine Passing Modes

- Identity verification is needed when entering and exiting from a place.
- Identity verification is needed when entering a place; and identity verification is not needed when exiting from the place through the turnstile.
- Identity verification is needed when entering a place; and exiting from the place through the turnstile is not allowed.
- Identity verification is not needed when entering a place through the turnstile; and identity verification is needed when exiting from the place through the turnstile.
- Identity verification is not needed when entering and exiting from a place through the turnstile.
- Identity verification is not needed when entering a place through the turnstile; and exiting from the place through the turnstile is not allowed.

- Entering a place through the turnstile is not allowed; and identity verification is needed when exiting from the place.
- Entering a place through the turnstile is not allowed; and identity verification is not needed when exiting from the place.
- Entering and exiting from a place through the turnstile is not allowed.

2 Application

Information of cards and face images can be collected from turnstiles or be imported to turnstiles through network.

Figure 2-1 Application

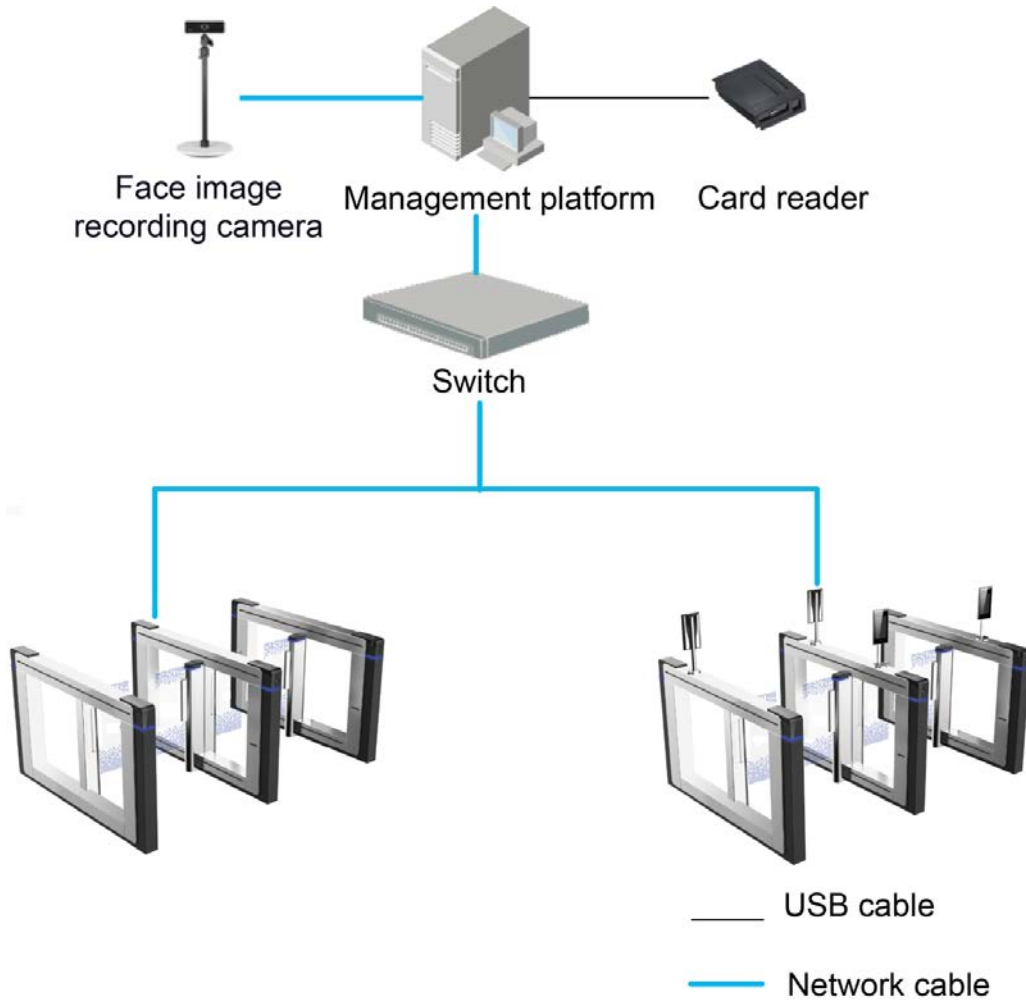

3 Structure

3.1 Appearance

There are two types of turnstiles: One-motor module turnstiles and two-motor module turnstiles. The turnstile in the middle is two-motor module turnstile, and the others are one-motor module turnstiles.

Figure 3-1 Appearance (1)

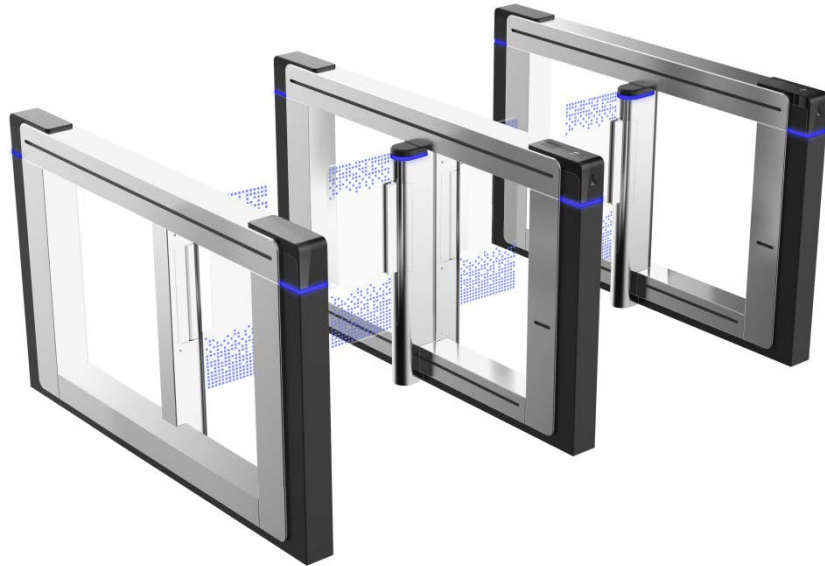
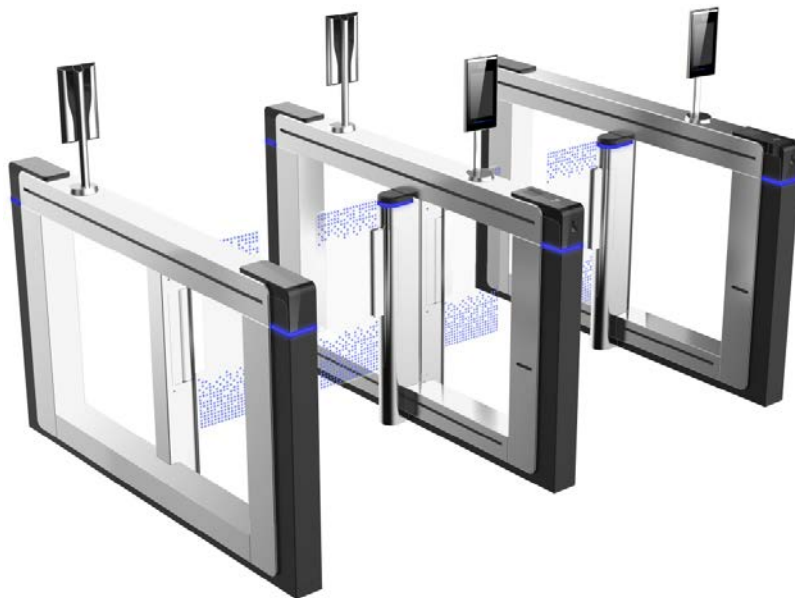
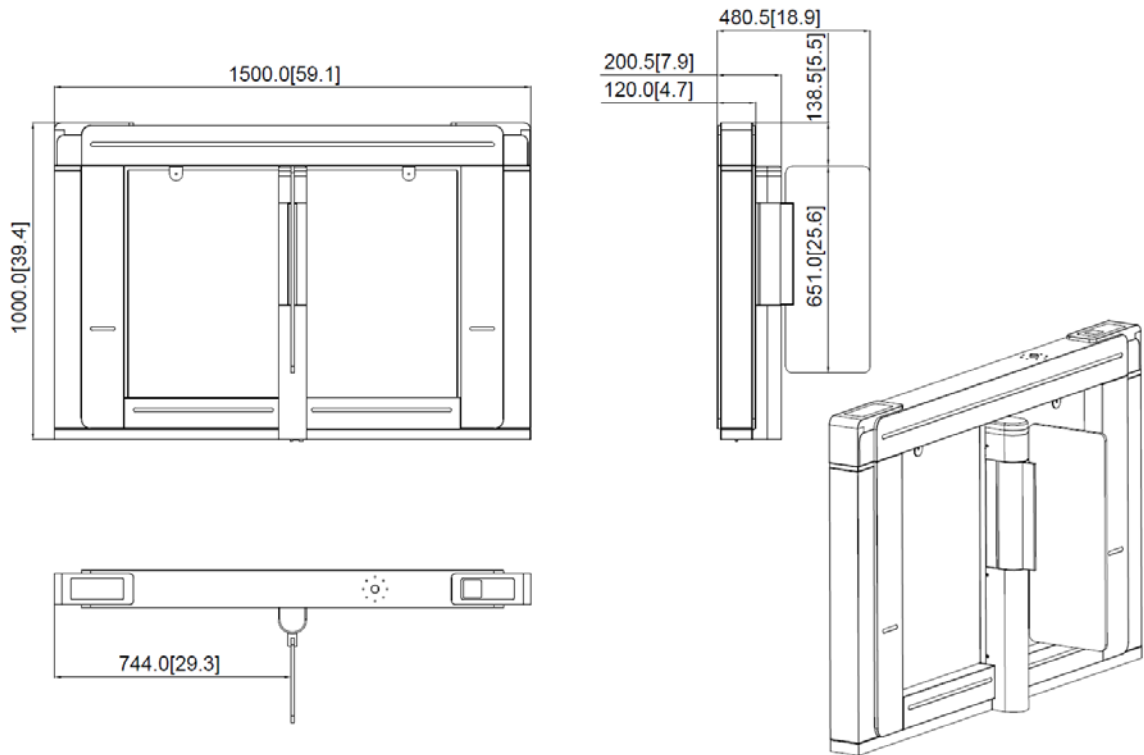

Figure 3-2 Appearance (2)



3.2 Dimensions

Figure 3-3 Dimensions (mm [inch])



3.3 Inner Components

Figure 3-4 Inner components

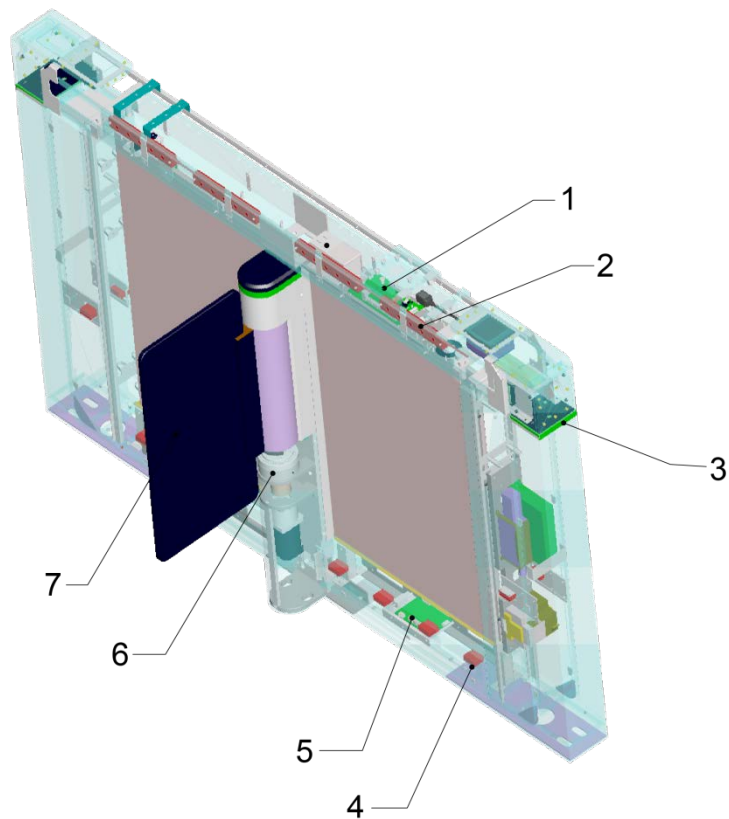

Table 3-1 Inner components description

| No. | Name | Description |
|-----|--------------------------|--|
| 1 | Turnstile control panel | It is the turnstile control center. It receives, judges, and processes turnstile location synchronization signals and firefighting signals, and signals from access control main board and IR sensor; and then sends orders to turnstile indicator lights, electric motors, alarm devices, and counters. |
| 2 | Light curtain sensor | Collect the location information of passages. |
| 3 | Passage indicator lights | <ul style="list-style-type: none"> ● Green light glows: Authenticated, barriers locked. ● Green light flashes: Passage is allowed. ● Red light flashes: Device anomaly or in alarm status. ● Blue light glows: Standby status. |
| 4 | IR sensor | Collect the location information of passages. |
| 5 | Motor driver panel | Externally connected with encoder, clutch and motor. Receives signals from the turnstile control panel to control the motor rotation and clutch engagement. |
| 6 | Clutch | Used for emergency braking of barriers. |
| 7 | Swing barrier | Locks and unlocks the turnstile. |

4 Installation

4.1 Safety Instructions



WARNING

- You need to strictly confirm to requirements in the manual during installation; otherwise we shall not be responsible for any loss occurred.
- Incorrect installation and improper operation might bring damages to humans or objects.
- Security devices and control devices used must confirm to EN12978 standard.
- Before installing, wiring, and dismantling the turnstile, disconnect the turnstile from power source first.
- The turnstile consists of various mechanical and electrical devices, any neglect during installation might cause damage.
- If smoke, unpleasant odor, and strange noise come out, turn off the power, unplug the turnstile, and then contact the dealer or service center.
- Do not dismantle the turnstile cover unless necessary; otherwise human and property damage and loss might occur.



- Install the turnstile firmly.
- When connected to 220V AC power, ground cable must be correctly connected.
- Before operating the turnstile, make sure that owners and operators can all see the turnstile status.
- Humans are not allowed to stand between turnstiles to operate after the turnstile is powered on.

4.2 Before Installation

- Make sure that the ground where the turnstile is installed is flat.
- Build a concrete base (above 100 mm high) when the turnstile needs to be installed at places with high humidity or are easily water-logged. Apply silicone sealant to gaps between the ground and turnstile to prevent water and condensation.
- Make sure that the PVC pipe is buried more than 150 mm under the ground, and the height of the PVC pipe above the ground should be greater than 50 mm. Bend the PVC pipe end that get out of the ground to prevent water leakage. Keep the ground where the turnstile is installed dry.

Figure 4-1 Installation drawings (mm [inch])

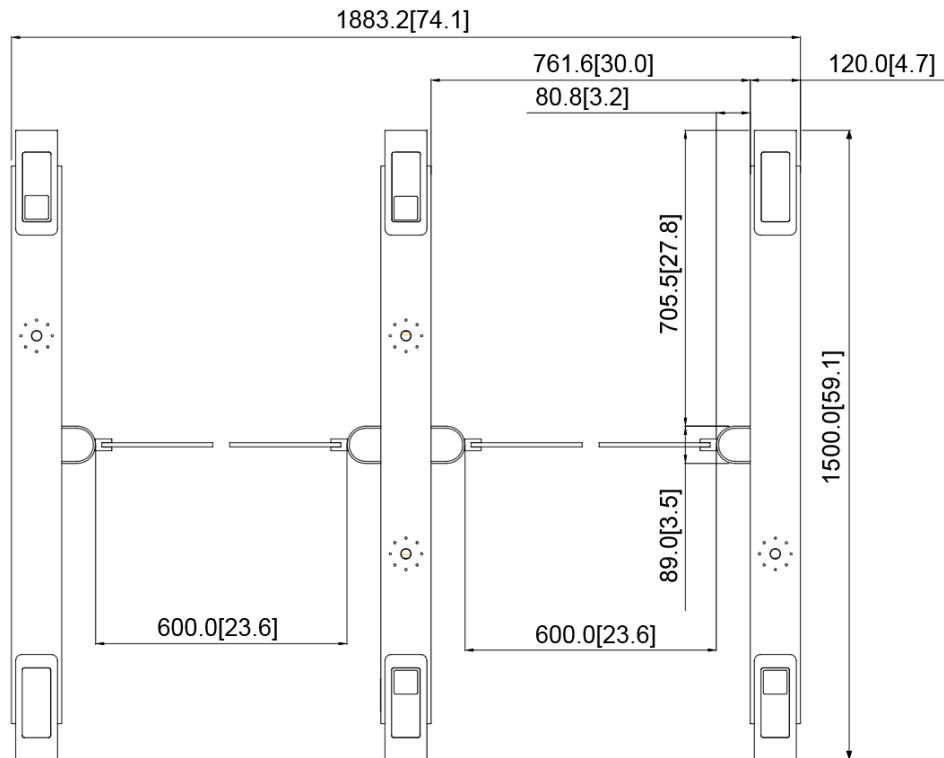

4.2.1 Tools

Tools might vary according to installation surfaces.

- Cement ground
Percussion drill, drill No.16, marking pen, tape measure, levelling instrument, hammer, wrench, angle grinder, cutting machine, and screwdriver.
- Marble and ceramic ground
Due to fragileness of marble and ceramic ground, use pistol drill to drill holes on marble and ceramic ground, and then use percussion drill to make the holes deeper.

4.2.2 Cable Connection

- Before laying cables, check that the cable labels are clear labeled.
- Make sure that AC power cable, communicating cable, and signal cable are separate (power cables with higher frequency, greater power and current and those with lower frequency, less power and current must not be placed in the same PVC pipe).
- Bury the PVC pipes deeper than 150 mm. The length of PVC pipe that on the ground should be longer than 50 mm.
- Thread PVC pipes through cable entry on the installation base.

Figure 4-2 PVC pipe layout (mm)

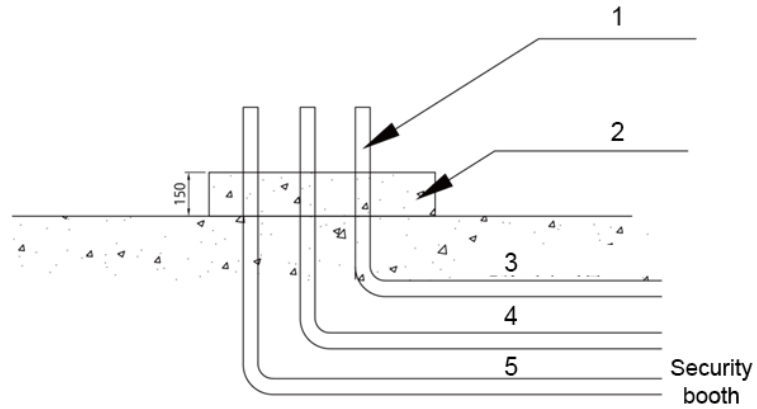

Table 4-1 PVC pipe layout description

| No. | Name |
|-----|--------------------------|
| 1 | 1" PVC pipe |
| 2 | 425# cement base |
| 3 | Power cable pipe |
| 4 | Signal cable pipe |
| 5 | Communication cable pipe |

Figure 4-3 Cable connection

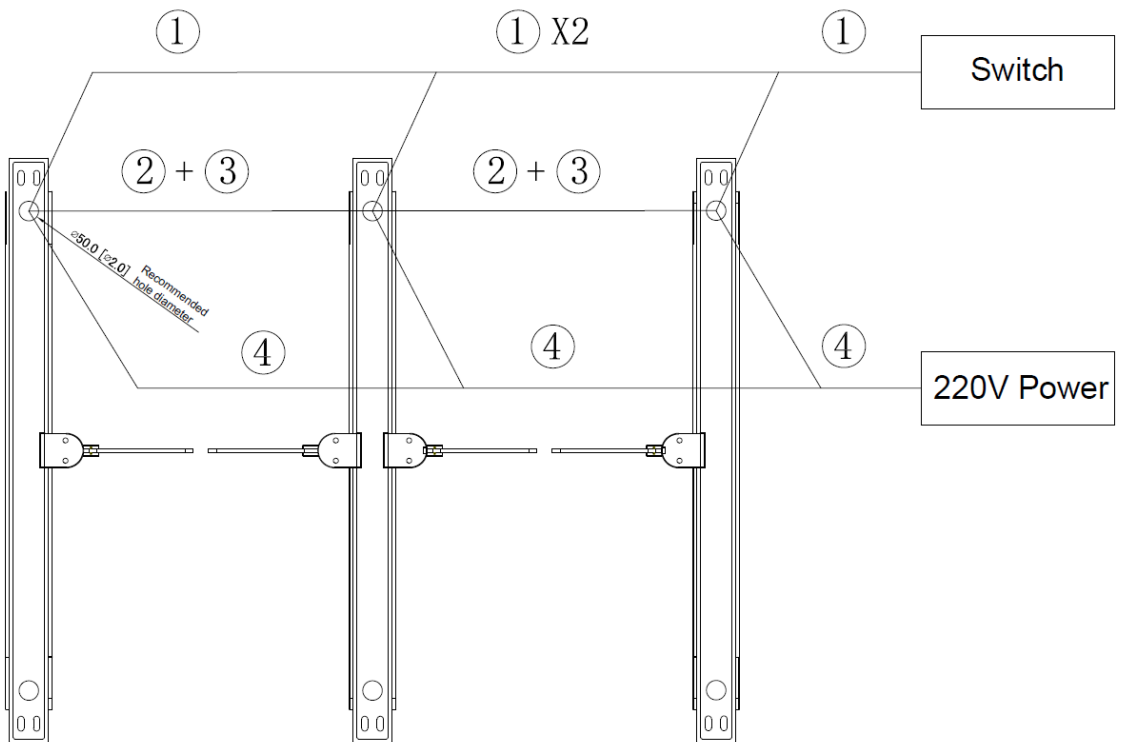



Table 4-2 Cable connection

| Cable number | Cable type | Description |
|--------------|---|---|
| 1 | Network cable (CAT5) | Two-way face unlock turnstile. Connect 1 network cable for the turnstiles on the left and right respectively, and connect two network cables for the turnstile in the middle. Make sure that the cable outside the cable entry is 3 meters long. |
| 2 and 3 | Turnstile synchronization cable and light curtain cable | Connect the two turnstiles with 2 cables (one 4-core CAN and RS-485 cable and one light curtain cable). Make sure that the cable outside the cable entry is 2 meters long.  The synchronization cable and light curtain cable are provided. |
| 4 | Power cable | Connect 1 network cable for each turnstile, and make sure that the cable outside the cable entry is 3 meters long. |

4.2.3 Cable Layout Diagram

For recommended cable layout, see Figure 4-4. If you lay cables incorrectly like Figure 4-5 does, the turnstile might not be firmly installed and cables might be broken when hammering expansion screws.

Figure 4-4 Recommended cable layout (mm [inch])

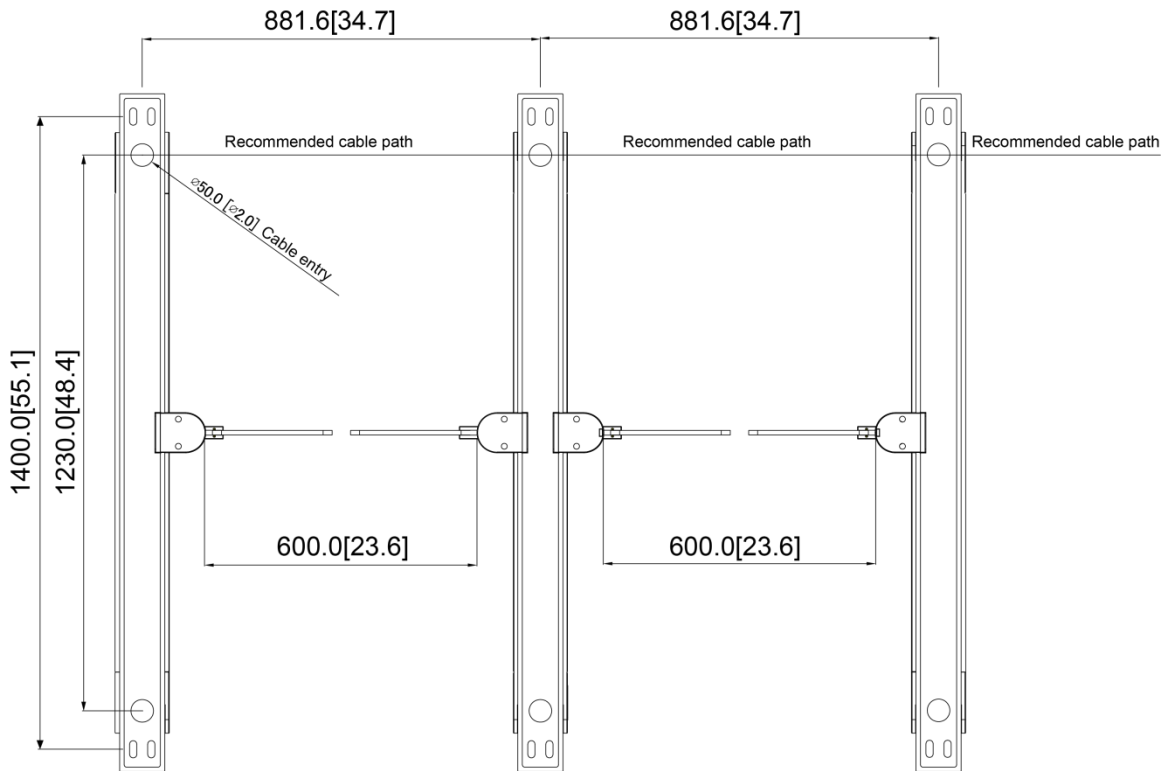
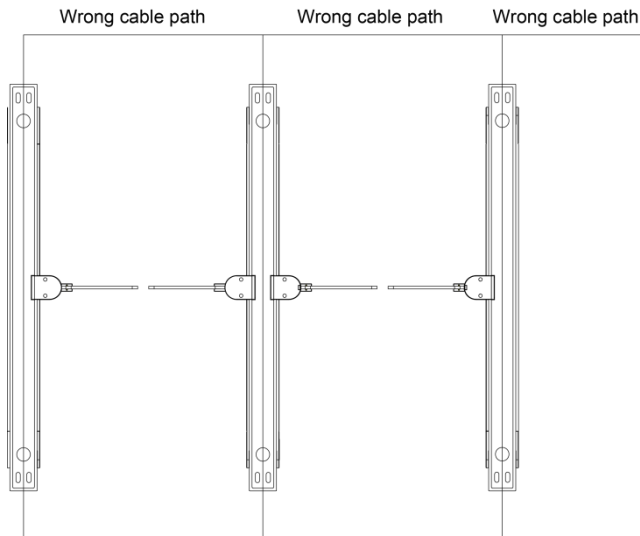

Figure 4-5 Wrong cable layout



4.3 Installation Procedure

4.3.1 Drilling Holes

Before installing turnstiles next to buildings, leave some space between the turnstiles and buildings.

- Arrows on the inner cover of the turnstile must point to the same direction.
- When installing turnstiles next to buildings, make sure that their distance is no less than 70 mm and no more than 100 mm. This distance enables that turnstile cover can be opened

during maintenance, and prevents human from passing through gaps between turnstiles and buildings.

Figure 4-6 Install turnstiles next to buildings

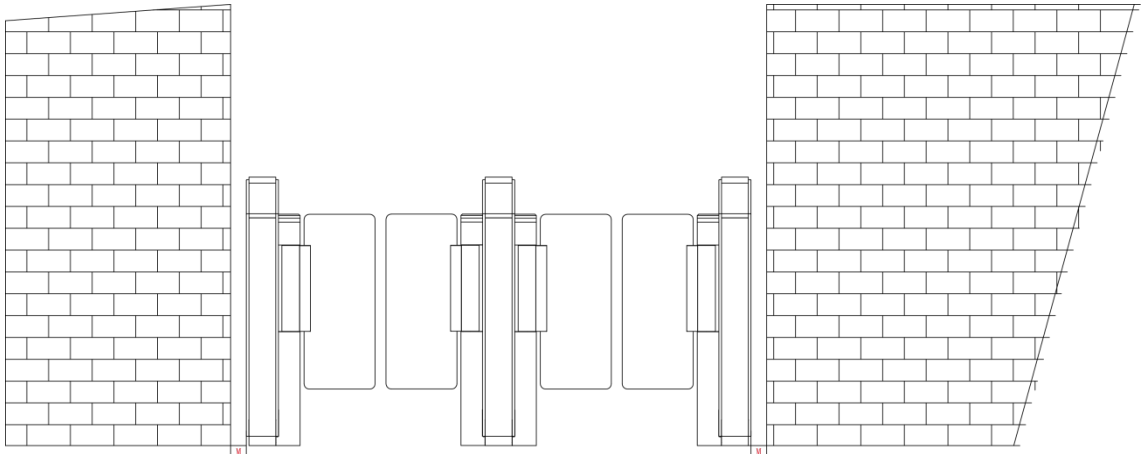

Step 1 Draw 6 turnstile installation holes. See Figure 4-7.

Figure 4-7 Hole drilling diagram(mm [inch])

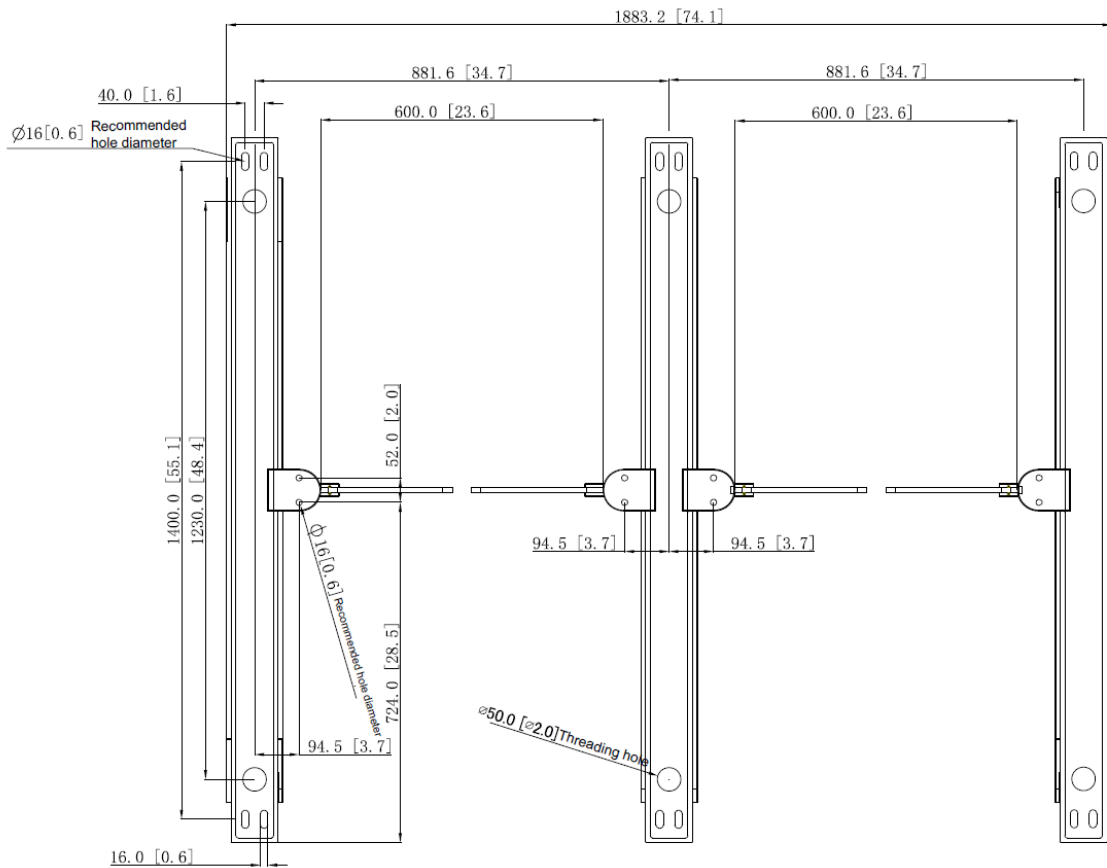

Step 2 Drill holes in the installation surface (like cement). For hole diameters, hole depth, and anchor bolt diameters, see Table 4-3.

Table 4-3 Anchor bolt specification

| Parameter | Dimensions |
|---------------------------|------------|
| Anchor bolt specification | M12x120 |
| Hole depth (mm) | 95 |
| Hole diameter (mm) | 16 |

Step 3 Compress air to remove dust in the holes.

Step 4 Hammer the anchor bolt into the hole bottom.

Step 5 Tighten the nut of the anchor bolt with the wrench, and then hammer the bolt again.

4.3.2 Adjusting Turnstile Position

Step 1 Loosen the fixing screws with a hex wrench, and then remove the upper cover and the side panel.



- Before removing the side panel, you need to unplug the LED light cable from the side panel.
- Handle gently to prevent scratches on the surface.

Figure 4-8 Turnstile cabinet doors

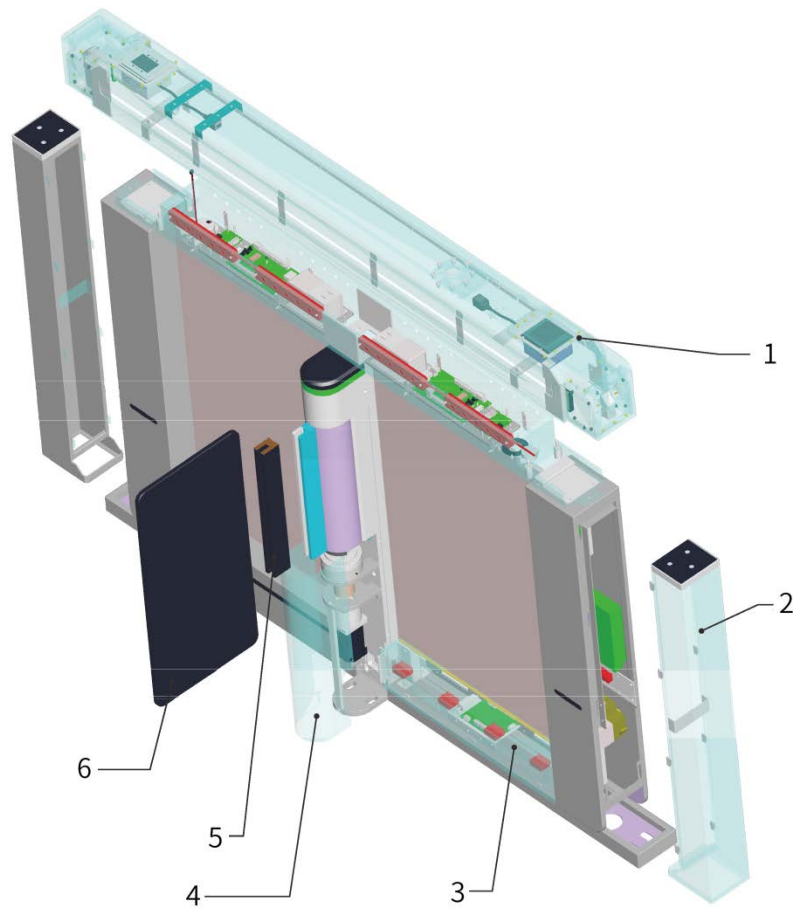
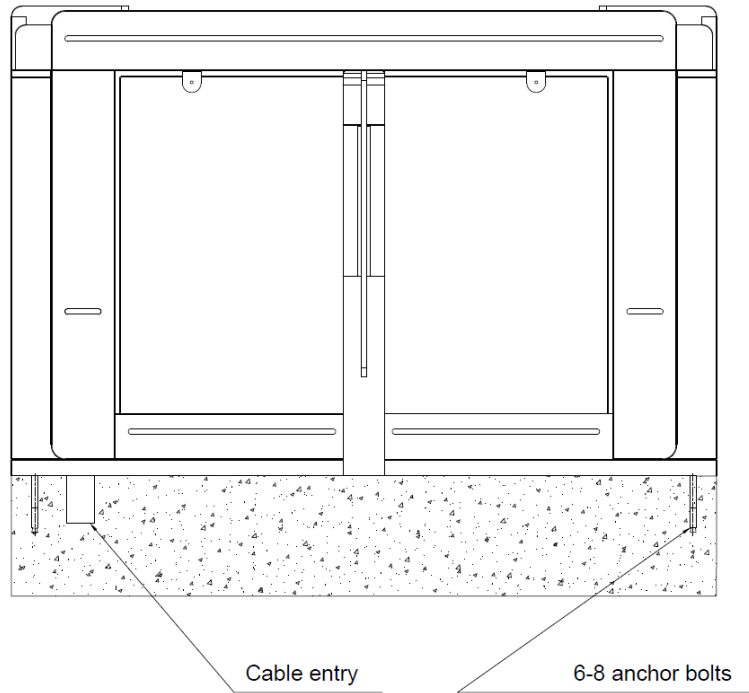

Table 4-4 Turnstile cabinet doors

| No. | Name |
|-----|------------------|
| 1 | Upper cover |
| 2 | Side panel |
| 3 | Bottom cover |
| 4 | Motor cover |
| 5 | Decorative panel |
| 6 | Swing barrier |

Step 2 Thread cables through the turnstile cable entry, and keep them organized to avoid cable broken.

Figure 4-9 Cable entry



Step 3 Lift the turnstile, adjust its position, make the holes in the turnstile overlap with the anchor bolt, and then place the turnstile on the ground.

Step 4 Use a gradienter to measure angles of inclination of the ground where the turnstile is installed. For appropriate flatness tolerance, see Figure 4-10.

Figure 4-10 Ground flatness tolerance

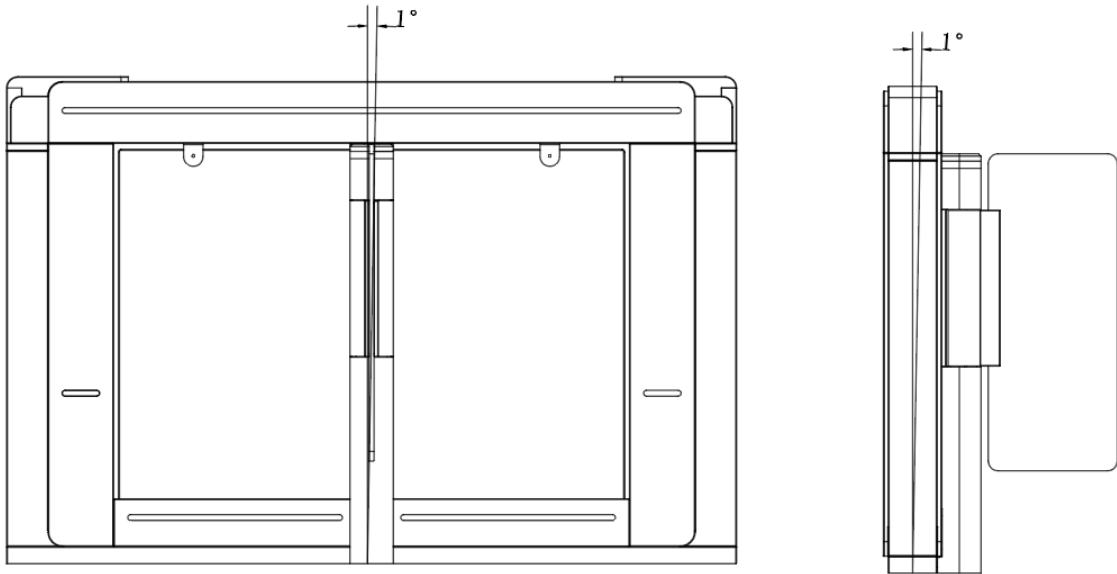

Step 5 Repeat Step 1–Step 4 to install other turnstiles.

- Arrows on the inner cover of the turnstile must point to the same direction.

Figure 4-11 Upper cover direction

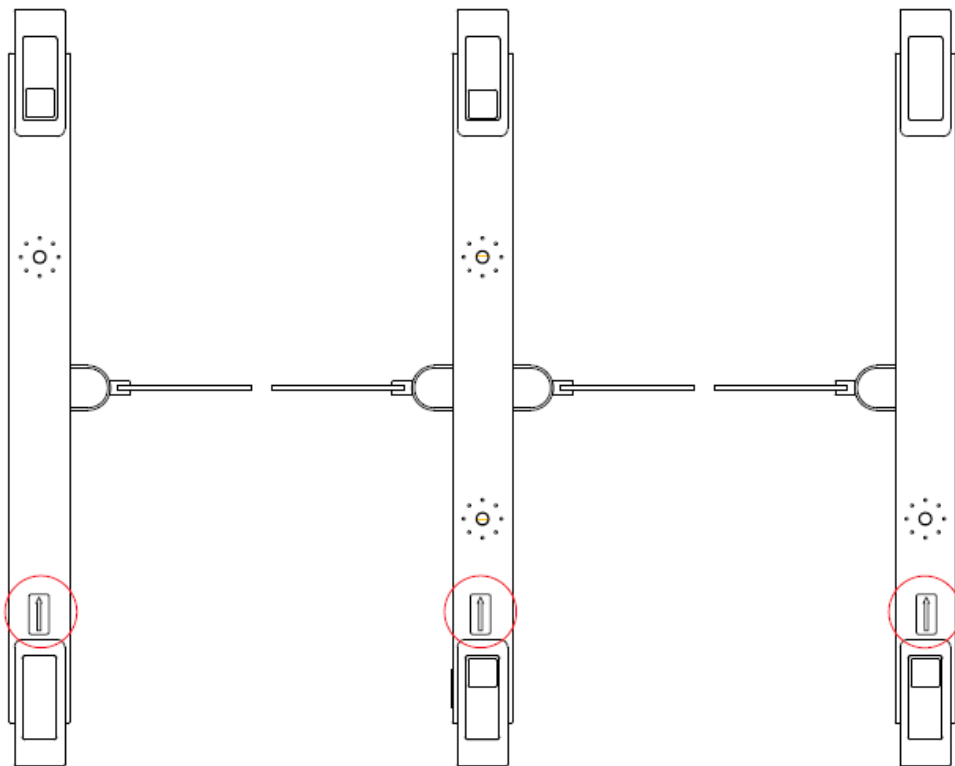
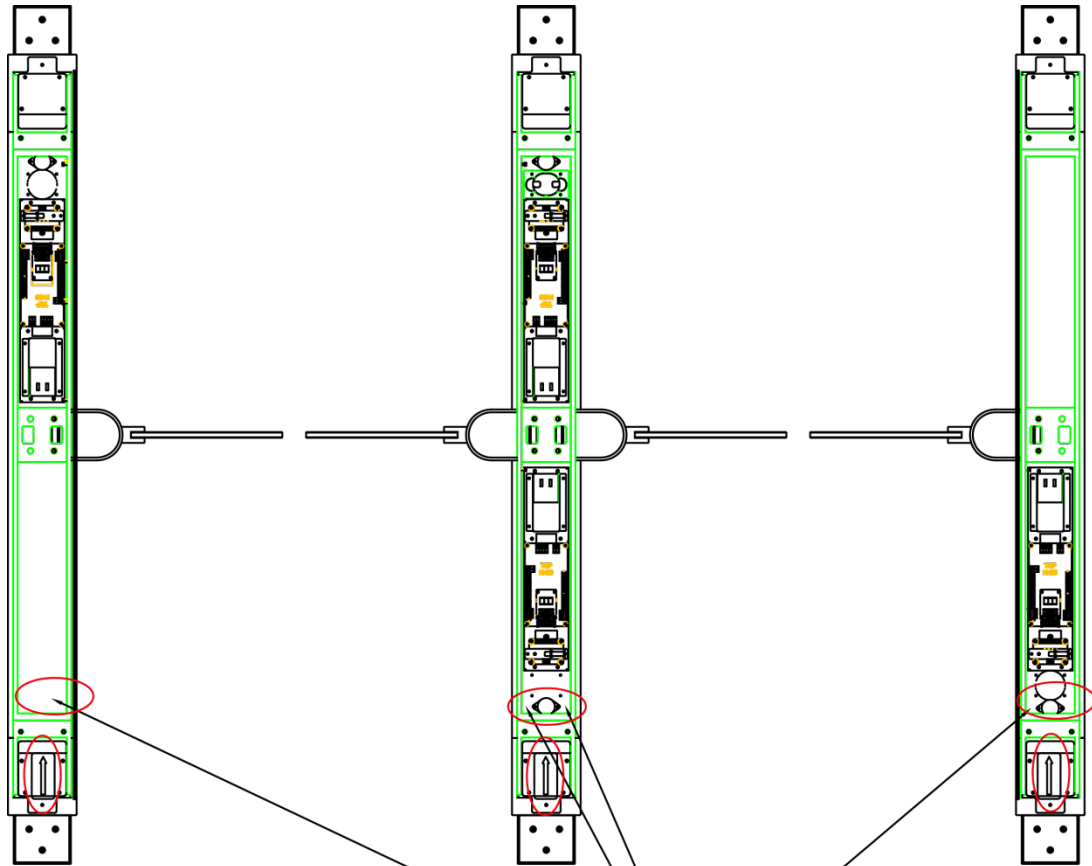

Figure 4-12 Light curtain connector location



Light curtain connector

- Make sure that height difference and parallelity difference of turnstiles are within the appropriate range.

Figure 4-13 Height difference (mm [inch])

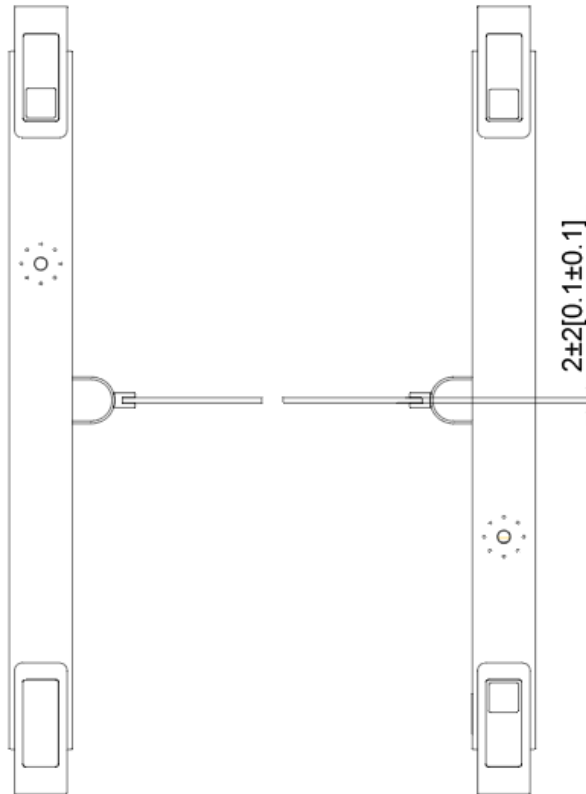
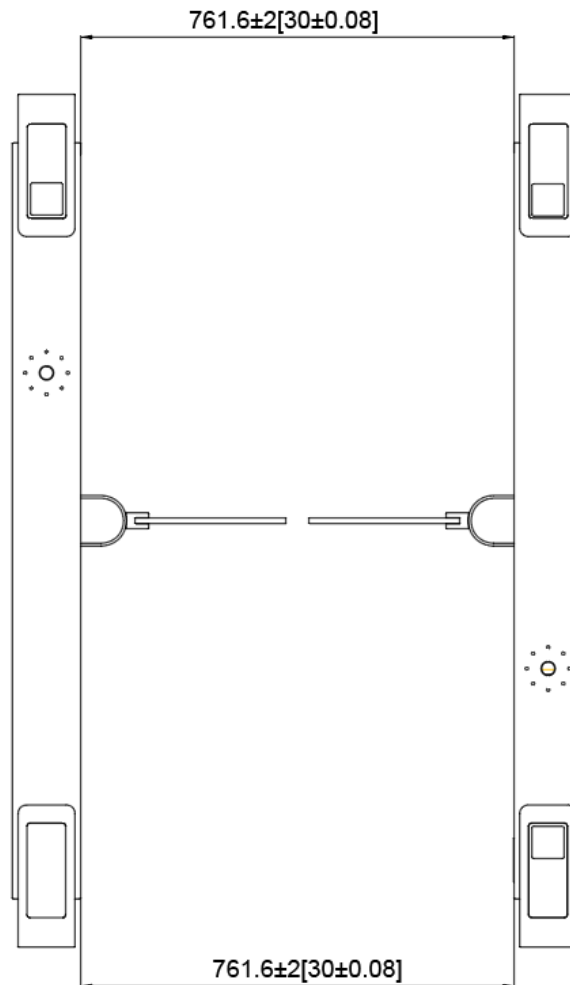

Figure 4-14 Parallelity difference (mm [inch])



4.3.3 Fixing Turnstiles

Step 1 After adjustment, put M10 surface gasket, M10 spring gasket, and M10 nut on the anchor bolt, and then tighten the nut manually. See Figure 4-15.

Step 2 Tighten all nuts with the wrench.

Step 3 Apply silicone sealant to gaps between the turnstile and the ground to avoid water leakage.

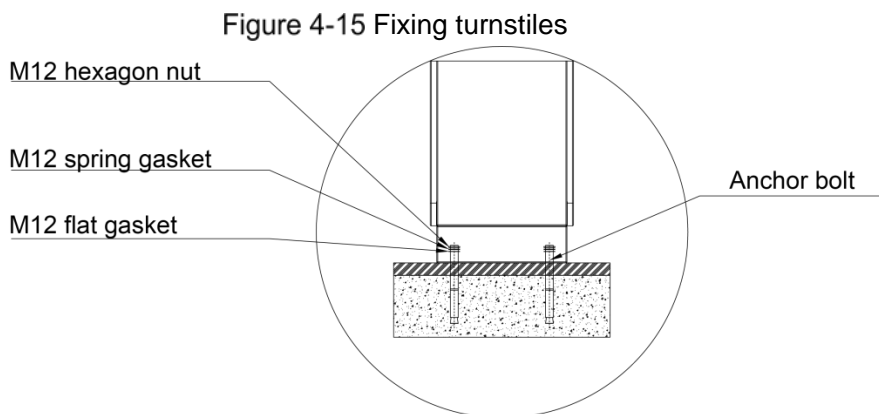

4.3.4 Installing Swing Barriers

Step 1 Loosen and take out the two M3 screws with a screwdriver, and then pull up the decorative panel.

Step 2 Loosen and take out the three M6 screws, and then take out the door cover.

Step 3 Place the swing barrier in the proper position and put back the decorative panel. Make sure that the screw position of the door cover and the screw position of the swing barrier are aligned and tightened.

Step 4 Tighten the two M3 screws to complete the installation.

Figure 4-16 Installing swing barriers

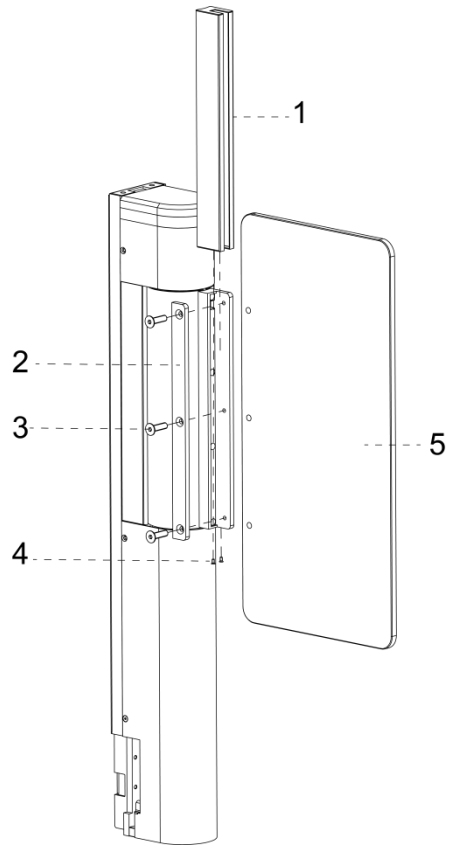

Figure 4-17 Installing swing barriers

| No. | Name |
|-----|------------------|
| 1 | Decorative panel |
| 2 | Door cover |
| 3 | M6 screw |
| 4 | M3 screw |
| 5 | Swing barrier |

5 Cable Connection

5.1 Turnstile Control Panel Port Description

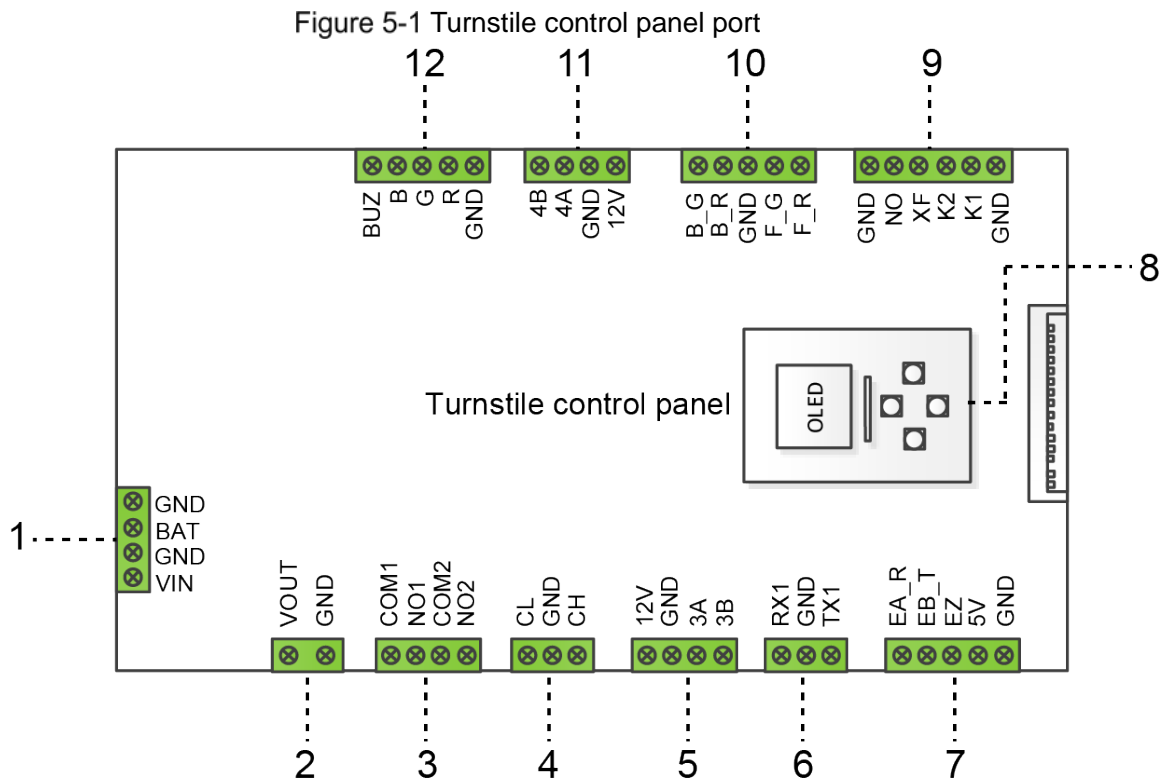

Table 5-1 Turnstile control panel port description

| Port No. | Description |
|----------|--|
| 1 | <ul style="list-style-type: none"> ● GND, +24V: Inputs 24V/6.5A DC power source for the control panel. ● GND, BAT: Connected to storage batteries; when AC power is disconnected, storage batteries start to work. |
| 2 | VOUT, GND: 24V power output for powering the motor driver board. |
| 3 | COM1/NO1 receives entering signals and COM2/NO2 receives exiting signals. The two relays can be configured to output alarm signals or population volume signals. |
| 4 | Connects two swaying barriers with synchronization cable to synchronize their movements. |
| 5 | 12V, GND, 3A, 3B: RS-485 port for program update. |
| 6 | RS-232 port for connecting access controller or face recognition terminal. |
| 7 | <ul style="list-style-type: none"> ● GND, 5V: Ground port of the power supply and 5V power input port. ● EA_R, EB_T, EZ: Communicates with RS-232 port of motor driver board. |
| 8 | Display module, for turnstile local configuration. |

5.3 Face Recognition Terminal of ASI7/8 Series (One-way Face Unlock & Two-way Card Unlock)



- Set the DIP switch of the face recognition access controller to 0000001, and set the DIP switch of the IC card reader to 00000000.
- The IP address of the access controller is 192.168.1.108 by default; the username is admin, and the password is admin by default.

Figure 5-3 Face recognition terminal of ASI7/8 series cable connection (1)

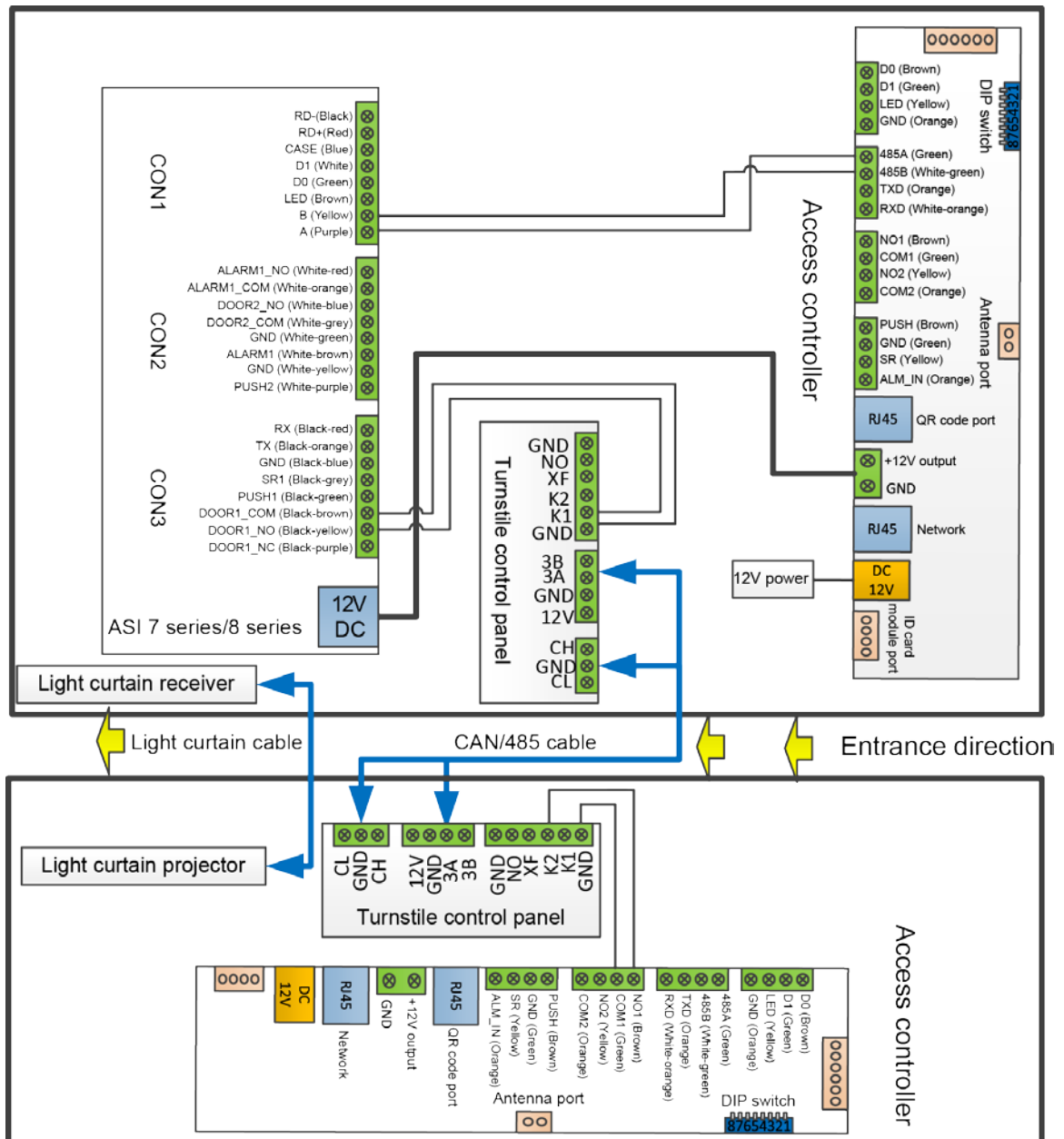

5.4 Face Recognition Terminal of ASI7/8 Series (Two-way Face Unlock & Two-way Card Unlock)



Set the DIP switch of the face recognition access controller to 0000001.

Figure 5-4 Face recognition terminal of ASI7/8 series cable connection (2)

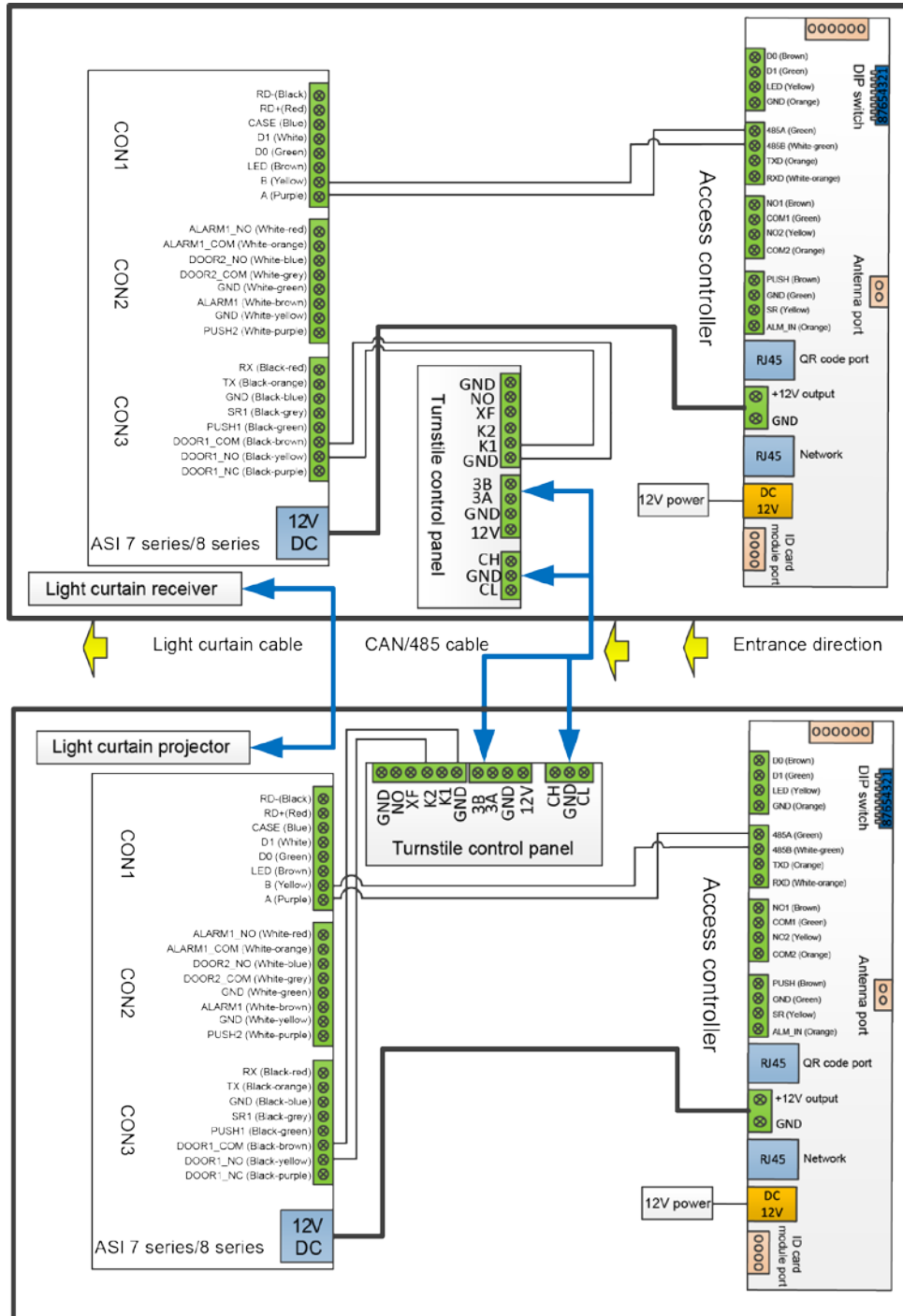

6 Configuration and Commissioning

Parameters can be configured through the four buttons on the turnstile. Parameters configured on each turnstile can be synchronized (except barrier origin).

6.1 Display Operation

Figure 6-1 Display buttons

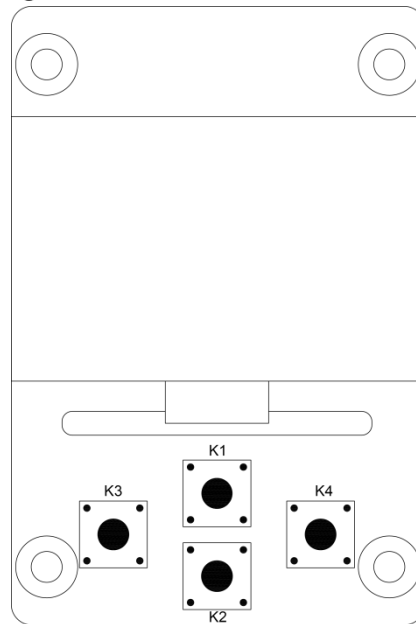

Table 6-1 Button description

| Button name | Description |
|------------------|---|
| K1: Up | Press the button to move up the menu items or adjust the current parameter value. |
| K2: Down | Press the button to move down the menu items or adjust the current parameter value. |
| K3: Exit | Press the button to exit the menu or cancel the current configuration. |
| K4: Menu/Confirm | Press the button to enter the menu or confirm current configuration. |

6.1.2 Working Mode

The turnstile supports 2 working modes:

- Normally open mode

This mode is applicable when there might be a great number of people passing the turnstile in a certain period.

- Normally closed mode

When normally closed mode is selected, the turnstile cannot be unlocked by anyone.

6.1.3 Passage Control Mode

The turnstile supports 9 passage control modes:

- Identity verification is needed when entering and exiting from a place (default mode).
- Identity verification is needed when entering a place, and identity verification is not needed when exiting from the place.
- Identity verification is needed when entering a place, and exiting from the place is not allowed.
- Identity verification is not needed when entering a place, and identity verification is needed when exiting from the place.
- Identity verification is not needed when entering and exiting a place.
- Identity verification is not needed when entering a place, and exiting from the place is not allowed.
- Entering a place is not allowed, and identity verification is needed when exiting from the place.
- Entering a place is not allowed, and identity verification is not needed when exiting from the place.
- Entering and exiting from a place are not allowed.

6.1.4 Passing Duration Settings

Passing duration is the maximum duration allowed for passengers to pass the turnstile after identity verification. Passengers need to pass the turnstile within the passing duration; otherwise the stay overtime alarm will be triggered.

The following passing duration options are available:

- 2s
- 5s
- 10s (default)
- 15s
- 20s
- 30s
- 45s
- 60s

6.1.5 Lock Delay Settings

Lock barriers a certain period later than the passing duration.

The following lock delay duration options are available:

- 0s (default)
- 2s
- 3s
- 5s
- 8s
- 15s
- 30s

- 60s

6.1.6 Security Level Settings

- 1: Trailing others and exiting through the turnstile when others are entering are allowed and light alarm will be triggered. The barrier will not be locked in both normally open mode and normally closed mode.
- 2: Trailing others and exiting through the turnstile when others are entering are not allowed and sound and light alarm will be triggered. The barrier will not be locked in both normally open mode and normally closed mode.
- 3: Trailing others and exiting through the turnstile when others are entering are not allowed.
 - ◇ When visitors with permission have passed the turnstile, sound and light alarm will be triggered before trailing people and people try to take the chance to exit through the turnstile entered the anti-pinch area (IR sensor can detect humans before they enter the anti-pinch area). The barriers will be locked in both normally open mode and normally closed mode.
 - ◇ When visitors with permission and people try to take the chance to exit through the turnstile have not entered the anti-pinch area, the barrier will be locked.
 - ◇ When trailing people and people try to take the chance to exit through the turnstile entered the anti-pinch area, sound and light alarm will be triggered. The barrier will not be locked in both normally open mode and normally closed mode. The barriers will be locked after trailing people and people try to take the chance to exit through the turnstile have passed the turnstile.
- 4: Trailing others and exiting through the turnstile when other people are entering a place are not allowed. When visitors with permission have passed the turnstile, sound and light alarm will be triggered wherever the trailing people and people try to take the chance to exit through the turnstile are. The barrier will be locked in both normally open mode and normally closed mode.

6.1.7 Second Unlock Settings

After people entered the passing area and alarms are triggered, they do not need to step backwards and can get their identity verified directly. Second unlock is on by default.

6.1.8 Memory Mode Settings

After swiping card once, more than one person can pass the turnstile. Memory mode is off by default.

- If several people are permitted to pass the turnstile, and one of them did not pass the turnstile in 5 seconds, or stayed overtime between the turnstiles, the swing barriers will be locked. At this time, you need to swipe cards several times to allow several people pass the turnstile continuously.

- In the memory mode, if the authorization interval exceeds the passing duration, the number of passing authorizations will not be accumulated.
- The interval between two identity verifications must be longer than the unlock duration of the access controller; otherwise, only one identity verification will be counted. The recommended identity verification is 2 s to 5 s.
- In the memory mode, at most 255 people can pass the turnstile continuously.

6.1.9 Unlock and Lock Speed Settings

The following unlock and lock speed levels are available:

- 1: The slowest
- 2
- 3
- 4
- 5
- 6: Default
- 7
- 8: The fastest



The speed increases from 1 to 8.

6.1.10 Volume Settings

The following volume levels are available:

- 1: Mute
- 2: The lowest
- 3
- 4
- 5
- 6: Default
- 7
- 8: The highest



The volume increases from 1 to 8.

6.1.11 Unlock Settings After Power-off

The unlock direction after power-off can be set to Exit or Enter. Exit is by default.



The unlock direction cannot be configured when the power-off is triggered by the firefighting signals. The unlock direction after power-off is Exit.

6.1.12 Start Mode

Table 6-2 Start mode settings

| Function | Mode |
|------------|--|
| Normal | Normal mode. After setting origin start, you need to set the start mode to normal mode. |
| Origin | Original position adjustment mode. You need to adjust original positions of barriers for the first use. <ol style="list-style-type: none">1. After power-on, go to the menu Start Mode, and then select the Origin option.2. Power off the turnstile, and align the two swing barriers.3. Power on the turnstile, and wait for the swing barriers stopping swing, and then set the start mode to normal mode. |
| Aging test | Test mode.  Test mode is indented for developers, and non-developers are prohibited to use this mode. |

6.1.13 Origin Settings

There are 2 origin modes are available: Left origin and right origin.

6.1.14 Passage Width Settings

Passage width range is 600 mm–1200 mm. The following passage width options are available:

- 600
- 700
- 800
- 900
- 1000
- 1100 (only for Y turnstile)
- 1200 (only for Y turnstile)

You need to adjust the width according to barrier length. For passenger safety, if the passage width is ≥ 900 mm, security level cannot be set.



If the passage width is ≥ 900 mm, it is recommended to choose a speed of unlock and lock below 6. Excessive speed affects the motor life, and it is easy to hit intruder and trailing people.

6.1.15 System Information

Table 6-3 System information

| Menu | Information |
|-----------------------|--|
| Version | Software version number and compile date. |
| Counter | IN: passengers entered. OUT: passengers exited. |
| Restore | Restore to factory defaults. |
| Device type | Swing barrier or wing barrier. |
| Barriers material | Acrylic or stainless steel. |
| Light curtain status | Display light curtain status. |
| Clean passager number | Whether to clean passager number. |

6.1.16 Language

Language options: Simplified Chinese and English.

6.2 Power-On Test



All turnstiles must be connected to power source.

Before doing the power-on test, make sure that:

- All components of the turnstile work normally. The turnstile has been tested but the component connection might still be slightly different.
- The cable is properly connected.
- The synchronization cable is connected, and control panel cable connections of the turnstile in the middle are correct.
- The swing barriers are adjusted to the central position.

Step 1 Perform power-on self-test.

- 1) Power on the turnstile and adjust the start mode to origin mode, and then power off the turnstile.
- 2) Adjust and align the swing barriers to the correct position.
- 3) Restart the turnstile and the turnstile performs self-test automatically.

The swing barriers will swing left and right during the self-test.

After the swing, if the buzzer does not beep, it means that the self-test succeeds.

If the power-on self-test failed, the buzzer beeps, and the corresponding alarm prompts on the display.



Each time the turnstile is disconnected from power source and connected to power again, the turnstile will do power-on self-test. After the power-on self-test, the turnstile will go to normal working status.



During power-on self-test, passengers are not allowed to pass the turnstile, IR sensors cannot be blocked, and barrier movements cannot be interfered.

Step 2 Change the start mode to normal mode.

Step 3 Set passage control mode for the turnstile: Identity verification is not needed when entering and exiting from a place. Observe barrier movements and positions when unlocking and locking the turnstile.

When a person enters the passage, the barriers will automatically open, and when a person exits the passage, the barriers will automatically close.



After registering cards and assigning face unlock permissions, you can set passage control mode as identity verification is needed when entering and exiting from a place.

6.3 IR Light and Light Curtain Anomaly Determination

In display module of passage control mode, you can view the status of IR light and light curtain through System Info > Curtain Status.

Figure 6-2 Light curtain status

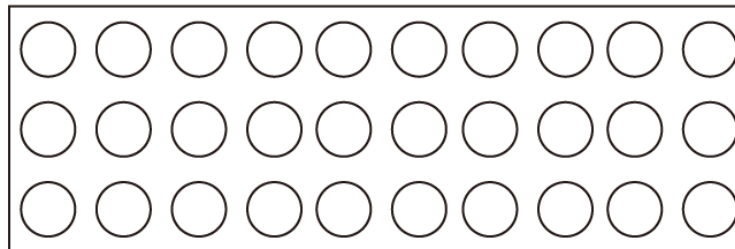

- The hollow circle indicates untriggered status and the solid circle indicates triggered status.
- The first row is an IR indication. Each dot corresponds to an IR, from left to right, IR 1, IR 2 ... IR 10.
- The second and the third rows are light curtain indication, and every 5 dots correspond to a light curtain:
 - ◇ Light curtain 1: 1-5 dots of row 2.
 - ◇ Light curtain 2: 6-10 dots row 2.
 - ◇ Light curtain 3: 1-5 dots of row 3.
 - ◇ Light curtain 4: 6-10 dots of row 3.
- To determine if it is abnormal:
 - ◇ If there is no block in the passage, the light curtain status is shown as Figure 6-2.
 - ◇ If IR 1 is blocked, the light curtain status is shown as Figure 6-3.

Figure 6-3 Light curtain status: IR 1 is blocked

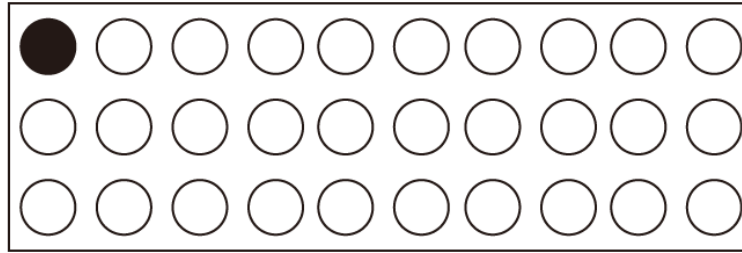

- ◇ If light curtain 1 is blocked, the light curtain status is shown as Figure 6-4.

Figure 6-4 Light curtain status: Light curtain 1 is blocked

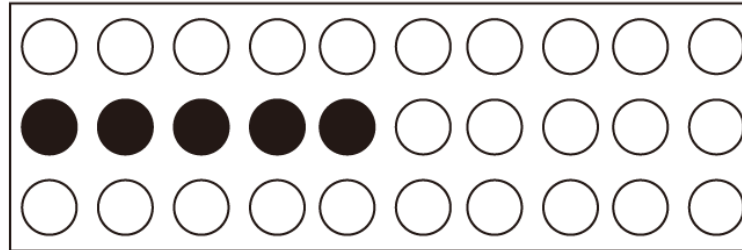

7 FAQ

1. After the turnstile is plugged in, power indicator light will not be on.

- 1) Check whether the power adapter works normally.
- 2) Check whether the codes of air switch are correct.

2. After the power-on self-test failed, the buzzer beeps and the power-on self-test error code "E01" is displayed on the numeric display.

- 1) Check whether IR sensors are blocked during power-on self-test.
- 2) Check whether all turnstiles are connected to power source.
- 3) Open the side door of the turnstiles, and then check whether the indicator light on the IR sensor board is red. If the indicator light is red, it means IR sensors are blocked or are not aligned.
- 4) IR sensors are broken. Contact technical support to change new IR sensors.

3. After the power-on self-test failed, the buzzer beeps and the power-on self-test error code "E02" is displayed on the numeric display.

Check whether communication cables of all turnstiles are correctly connected.

4. After power-on self-test failed, the buzzer beeps and the power-on self-test error code "E03" is displayed on the numeric display.

Check whether the barrier movements were interfered during the power-on self-test. If not, contact the technical support.

5. The barrier is disconnected from power source, swing barriers cannot be unlocked.

- 1) Check whether the battery cable is correctly connected.
- 2) Check whether the battery voltage is normal. The normal battery voltage is 12 V.

6. After a visitor swipe an authorized card, the barrier still cannot be unlocked.

- 1) Check whether the card is a valid card.
- 2) Check whether cable connection between data collection board and access controller is correct.

7. After a visitor pass the turnstile with the identity verified, the turnstile barriers cannot lock themselves.

Adjust the lock delay duration.

8. Trailing alarm is triggered when a visitor pass the turnstile with the luggage.

There are gaps between the visitor and the luggage. It is normal that trailing alarm being triggered.

9. Turnstile indicator lights are not on.

Check whether cable connection between passing direction indicator lights and passage indicator lights is correct.

10. Barriers cannot be locked or unlocked during days with heavy rains and passage indicator lights flash in red.

Dry rain drops on the acrylic plate, especially acrylic plate outside the IR sensors.

Appendix 1 Maintenance

Maintain the turnstile regularly; otherwise its lifespan or performance will be influenced.

Turnstile Exterior

- Maintenance period (depending on the site environment), for a better environment:
 - ◇ Outdoor, once every half month or after each raining day.
 - ◇ Indoor, once every two months.
- Maintenance content: Clean the turnstile cabinet and swing barriers.
 - ◇ Dip a piece of soft cloth in a neutral detergent or clean water, and then clean the cabinet surface.
 - ◇ High salinity and humidity environment, acid rain, and sweat will corrode the stainless cabinet surface. Use scouring pad to clean the rust (you can also use rust remover), and then dip a piece of soft cloth in a neutral detergent or clean water to clean the cabinet surface.

Turnstile Interior



Clean the power supply and circuit board. Do not use water to clean the interior to avoid short circuit.

- Maintain the turnstile once every three months.
- Maintenance content
 - ◇ Disconnect the turnstile from power source, open the turnstile cover, and then clean the dust inside.
 - ◇ Make sure that the motor, bearing, fastening device, screws, and more are tightened.
 - ◇ Apply lubricants to radius rods and gears.
 - ◇ Check whether there is loose cable connection. If yes, organize and cover bare cables, and then tighten screws. Replace the aged cables (if any).

Appendix 2 Maintenance of the Stainless Cabinet Surface

Appendix 2.1 Rust Protection and Adhesive Failure

Stainless steel will not get rusty unless it is used inappropriately in harsh environments.

Rust Protection

Do not make the turnstile be close to rust inducing substances; otherwise the turnstile might be more likely to get rusty.

- Ions, sulfur oxide, acidic substances that contains HCL and H₂SO₄, or substances that produce acidic substances (contain SO₄, salts, and HClO) after dissolving in water.
- Substances like soot and dust will impede the stainless steel producing protection film.
- Metal with iron powder will produce adhesive rust on the stainless steel.

Adhesive Failure Protection

After sticking protective film on the stainless steel, protect it from UV rays (direct sunlight), heat, pressure, and more to avoid adhesive failure.

Appendix 2.2 Removing Dirt and Rust

Remove Protective Film Mark

Use sponge or cloth dipped with mixed solutions of ethyl alcohol, naphtha, banana oil, methylbenzene, and acetonehunheye to clean the film mark. Clean solutions on the stainless steel surface with clean cloth. You must use clean water to clean the surface at last.

Clean Dirt and Fingerprints

Generally, neutral detergent or soap can remove dirt and fingerprints; otherwise, use organic solutions (ethyl alcohol and naphtha). After cleaning the surface with organic solutions, you should clean the solutions on the surface immediately. Stainless steel cleaner is recommended.

Clean less Rust

Use stainless steel cleaner to clean less rust.

Clean More Rust

If adhesive rust on the stainless steel was not cleaned in time, the stainless steel will get rusty. As time goes by, thick tawny rust or red rust is hard to remove.

Appendix 2.3 Precautions

Cleaning Requirement

- Cut off power supply before cleaning the turnstile. Do not wet components inside the turnstile.
- Make sure that the detergent you use does not contain abradant graininess; otherwise the turnstile surface will be damaged.
- Clean the surface along lines on the surface.
- Dry the surface after using detergent and clean water.

Detergent Requirement

- Do not use acidoid especially sulphuric acid, sulphurous acid, and acids that contain chlorine or nitrogen.
- If there is adhesive failure, use organic solutions that are without oxidability. Ethyl alcohol, dimethylbenzene, acetone are normally used.
- For stainless steel whose surface has been processed (mirror surface or titanium surface), make sure that the detergent does not contain abradant graininess.

Appendix 3 Cybersecurity Recommendations

Cybersecurity is more than just a buzzword: it's something that pertains to every device that is connected to the internet. IP video surveillance is not immune to cyber risks, but taking basic steps toward protecting and strengthening networks and networked appliances will make them less susceptible to attacks. Below are some tips and recommendations on how to create a more secured security system.

Mandatory actions to be taken for basic device network security:

1. Use Strong Passwords

Please refer to the following suggestions to set passwords:

- The length should not be less than 8 characters;
- Include at least two types of characters; character types include upper and lower case letters, numbers and symbols;
- Do not contain the account name or the account name in reverse order;
- Do not use continuous characters, such as 123, abc, etc.;
- Do not use overlapped characters, such as 111, aaa, etc.;

2. Update Firmware and Client Software in Time

- According to the standard procedure in Tech-industry, we recommend to keep your device (such as NVR, DVR, IP camera, etc.) firmware up-to-date to ensure the system is equipped with the latest security patches and fixes. When the device is connected to the public network, it is recommended to enable the "auto-check for updates" function to obtain timely information of firmware updates released by the manufacturer.
- We suggest that you download and use the latest version of client software.

"Nice to have" recommendations to improve your device network security:

1. Physical Protection

We suggest that you perform physical protection to device, especially storage devices. For example, place the device in a special computer room and cabinet, and implement well-done access control permission and key management to prevent unauthorized personnel from carrying out physical contacts such as damaging hardware, unauthorized connection of removable device (such as USB flash disk, serial port), etc.

2. Change Passwords Regularly

We suggest that you change passwords regularly to reduce the risk of being guessed or cracked.

3. Set and Update Passwords Reset Information Timely

The device supports password reset function. Please set up related information for password reset in time, including the end user's mailbox and password protection questions. If the information changes, please modify it in time. When setting password protection questions, it is suggested not to use those that can be easily guessed.

4. Enable Account Lock

The account lock feature is enabled by default, and we recommend you to keep it on to guarantee the account security. If an attacker attempts to log in with the wrong password several times, the corresponding account and the source IP address will be locked.

5. Change Default HTTP and Other Service Ports

We suggest you to change default HTTP and other service ports into any set of numbers between 1024~65535, reducing the risk of outsiders being able to guess which ports you are using.

6. Enable HTTPS

We suggest you to enable HTTPS, so that you visit Web service through a secure communication channel.

7. MAC Address Binding

We recommend you to bind the IP and MAC address of the gateway to the device, thus reducing the risk of ARP spoofing.

8. Assign Accounts and Privileges Reasonably

According to business and management requirements, reasonably add users and assign a minimum set of permissions to them.

9. Disable Unnecessary Services and Choose Secure Modes

If not needed, it is recommended to turn off some services such as SNMP, SMTP, UPnP, etc., to reduce risks.

If necessary, it is highly recommended that you use safe modes, including but not limited to the following services:

- SNMP: Choose SNMP v3, and set up strong encryption passwords and authentication passwords.
- SMTP: Choose TLS to access mailbox server.
- FTP: Choose SFTP, and set up strong passwords.
- AP hotspot: Choose WPA2-PSK encryption mode, and set up strong passwords.

10. Audio and Video Encrypted Transmission

If your audio and video data contents are very important or sensitive, we recommend that you use encrypted transmission function, to reduce the risk of audio and video data being stolen during transmission.

Reminder: encrypted transmission will cause some loss in transmission efficiency.

11. Secure Auditing

- Check online users: we suggest that you check online users regularly to see if the device is logged in without authorization.
- Check device log: By viewing the logs, you can know the IP addresses that were used to log in to your devices and their key operations.

12. Network Log

Due to the limited storage capacity of the device, the stored log is limited. If you need to save the log for a long time, it is recommended that you enable the network log function to ensure that the critical logs are synchronized to the network log server for tracing.

13. Construct a Safe Network Environment

In order to better ensure the safety of device and reduce potential cyber risks, we recommend:

- Disable the port mapping function of the router to avoid direct access to the intranet devices from external network.
- The network should be partitioned and isolated according to the actual network needs. If there are no communication requirements between two sub networks, it is suggested to use VLAN, network GAP and other technologies to partition the network, so as to achieve the network isolation effect.
- Establish the 802.1x access authentication system to reduce the risk of unauthorized access to private networks.

- Enable IP/MAC address filtering function to limit the range of hosts allowed to access the device.