

2-wire Switch

User's manual







Foreword

General

This manual introduces the structure and installation of the 2-wire switch (hereinafter referred to as the "switch").

Safety Instructions

The following categorized signal words with defined meaning might appear in the manual.

Signal Words	Meaning
 DANGER	Indicates a high potential hazard which, if not avoided, will result in death or serious injury.
 WARNING	Indicates a medium or low potential hazard which, if not avoided, could result in slight or moderate injury.
 CAUTION	Indicates a potential risk which, if not avoided, could result in property damage, data loss, lower performance, or unpredictable result.
 TIPS	Provides methods to help you solve a problem or save you time.
 NOTE	Provides additional information as the emphasis and supplement to the text.

Revision History

Version	Revision Content	Release Time
V1.0.1	Revised "Important Safeguards and Warnings".	December 2022
V1.0.0	First release.	December 2020

Important Safeguards and Warnings

This section introduces content covering the proper handling of the device, hazard prevention, and prevention of property damage. Read carefully before using the device, and comply with the guidelines when using it.

Operation Requirements



- Check whether the power supply is correct before use.
- Do not unplug the power cord on the side of the device while the adapter is powered on.
- Operate the device within the rated range of power input and output.
- Transport, use and store the device under allowed humidity and temperature conditions.
- If the device is powered off for longer than a month, it should be placed in its original package and sealed. Make sure to keep it away from moisture, and store it under allowed humidity and temperature conditions.
- Do not drop or splash liquid onto the device, and make sure that there is no object filled with liquid on the device to prevent liquid from flowing into it.
- Do not disassemble the device without professional instruction.

Installation Requirements



- Do not connect the power adapter to the device while the adapter is powered on.
- Strictly comply with the local electric safety code and standards. Make sure the ambient voltage is stable and meets the power supply requirements of the device.
- Do not connect the device to two or more kinds of power supplies, to avoid damage to the device.
- Improper use of the battery might result in a fire or explosion.



- Personnel working at heights must take all necessary measures to ensure personal safety including wearing a helmet and safety belts.
- Do not place the device in a place exposed to sunlight or near heat sources.
- Keep the device away from dampness, dust, and soot.
- Install the device on a stable surface to prevent it from falling.
- Install the device in a well-ventilated place, and do not block its ventilation.
- Use an adapter or cabinet power supply provided by the manufacturer.
- Use the power cords that are recommended for the region and conform to the rated power specifications.
- The power supply must conform to the requirements of ES1 in IEC 62368-1 standard and be no higher than PS2. Please note that the power supply requirements are subject to the device label.
- The device is a class I electrical appliance. Make sure that the power supply of the device is connected to a power socket with protective earthing.

Table of Contents

- Foreword..... I**
- Important Safeguards and Warnings..... II**
- 1 Introduction..... 1**
 - 1.1 Product Overview 1
 - 1.2 Application 1
- 2 Structure 3**
 - 2.1 Front panel 3
 - 2.2 Rear Panel 4
- 3 Installation..... 6**
 - 3.1 Installing with Screws..... 6
 - 3.2 Installing with a Guide Rail 6
- Appendix 1 Cybersecurity Recommendations 8**

1 Introduction

1.1 Product Overview

The switch provides one 2-wire P port, two 2-wire cascading ports and two RJ-45 ports. You can connect up to 10 switches together to bring as many as 200 devices into the network. This is applicable to an apartment where there are many tenants. When connected to network through the switch, 2-wire indoor monitors (VTH) can make calls, unlock doors and monitor.

1.2 Application

A single 2-wire switch can connect at most 20 VTHs and 2 door stations (VTOs). Based on the total number of devices, we have villa and apartment.

Villa

If there are no more than 20 VTHs and 2 VTOs, they can all connect to the same switch.

Figure 1-1 Villa network diagram

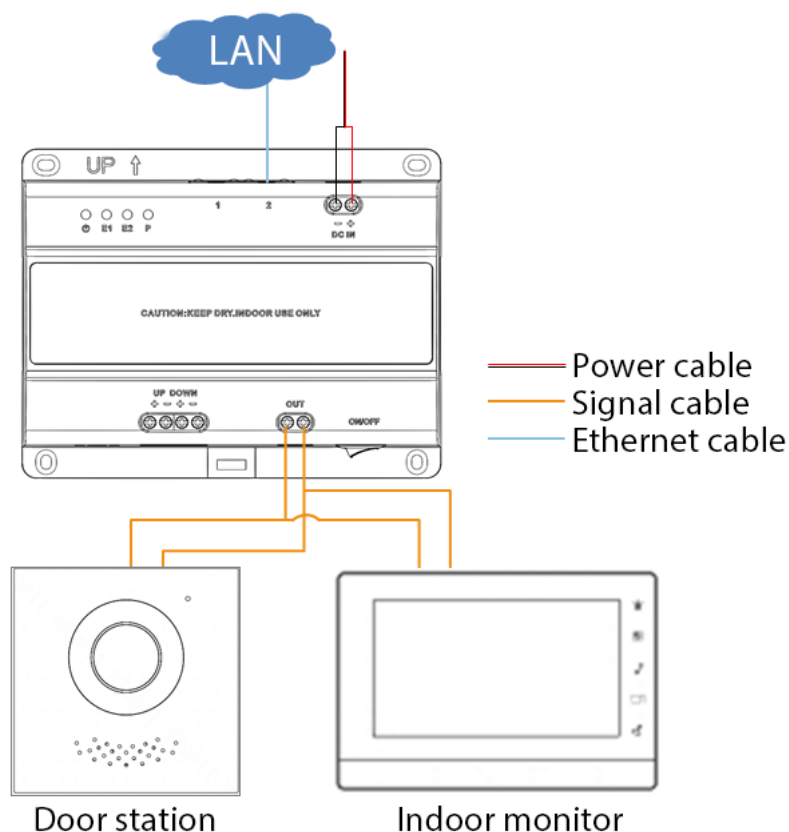

Apartment

If there are more than 20 VTHs and 2 VTOs, you need more than one switch to connect them all to the network. Use the 2-wire cascading ports or RJ-45 ports to connect the switches as needed, and make sure that all the switches are connected to the same network. Take cascading with the 2-wire cascading ports as an example.



The cable connection of cascading with RJ-45 ports is the same as villa.

Figure 1-2 Apartment network diagram with 2-wire cascading ports

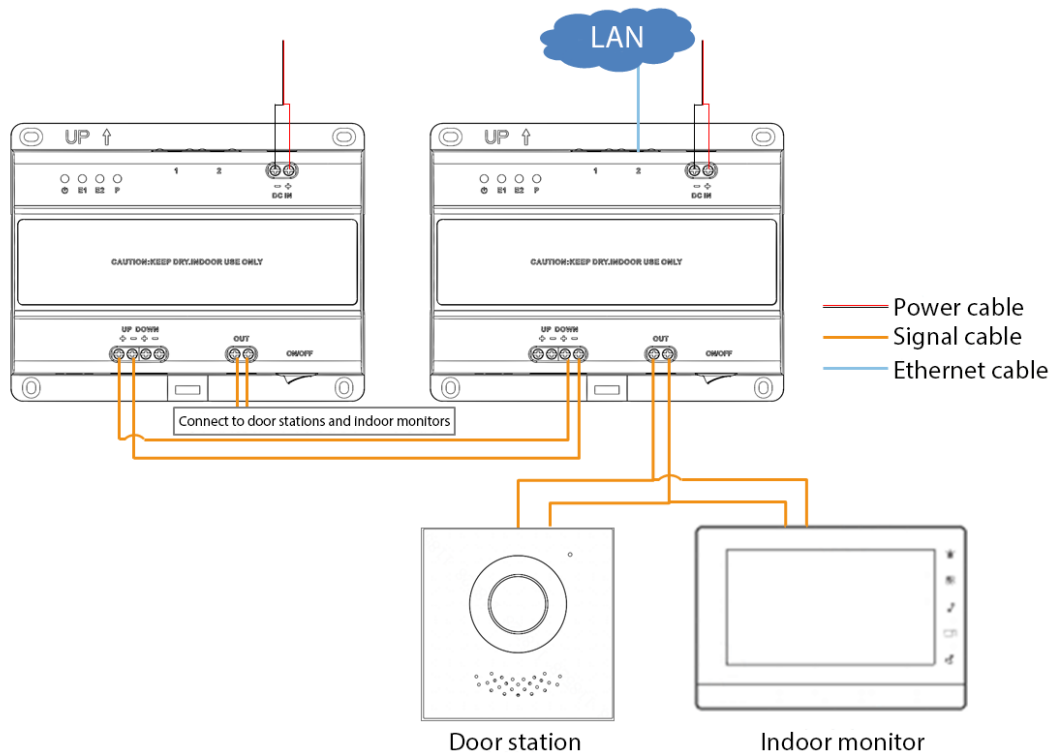

See the instruction below when choosing the right signal cables for the amount of devices you have:

R (total resistance) = $6V/\text{the number of VTHs}/0.1A$ (the average current for each VTH)

For example, the total resistance of the cables for 5 VTHs must be less than $6V/5/0.1A = 12\Omega$.

Table 1-1 Description of using different cables

Cable Type for Cascading	Supported Quantity	Device	Maximum Distance
2-core cable	20 VTHs and 2 VTOs.		50 m:
4-core cable			<ul style="list-style-type: none"> Between two switches. Between one switch and one VTH/VTO.
Ethernet cable	12 VTHs and 2 VTOs.		<ul style="list-style-type: none"> 50 m. Between two switches. 30 m. Between one switch and one VTH/VTO. <p>Because each core in an Ethernet cable has a relatively large impedance, we recommend that the cable should not be longer than 30 m.</p>



- The cable between 1 switch and one VTO/VTH must be longer than 1 m.
- When using multiple switches, make sure that each switch is at least 3 m from the other ones.

2 Structure

2.1 Front Panel

Figure 2-1 Front panel structure

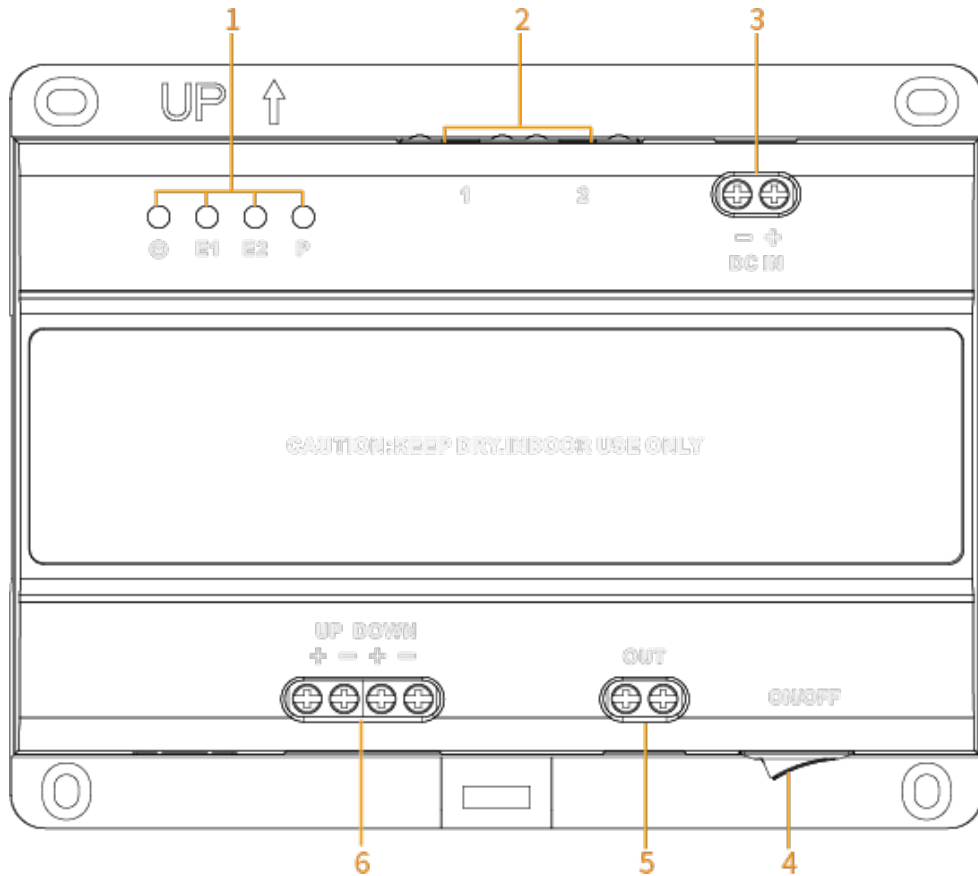



Table 2-1 Structure description

No.	Item	Description
1	Indicator	<p>From left to right:</p> <ul style="list-style-type: none"> ● POWER. <ul style="list-style-type: none"> ◇ Red: Powered on. ◇ Off: No power. ● E1. <ul style="list-style-type: none"> ◇ Green flashes: The device is properly connected to uplink port. ◇ Solid green: No signal from the uplink port. ◇ Off: The device is powered off or malfunctioning. ● E2. <ul style="list-style-type: none"> ◇ Green flashes: The device is properly connected to downlink port. ◇ Solid green: No signal from the downlink port. ◇ Off: The device is powered off or malfunctioning. ● P. <ul style="list-style-type: none"> ◇ Green flashes: Received PLC signal that either the VTH or VTO that is properly connected to the switch. ◇ Solid green: All VTHs and VTOs are not properly connected. ◇ Off: The devices are powered off or malfunctioning.
2	Network	2 RJ-45 ports.

No.	Item	Description
3	Power input	Use 48V DC power supply.
4	OFF/ON	Power switch.
5	2-wire ports	Connect up to 20 VTHs and 2 VTOs with no positive or negative poles.
6	Uplink and downlink ports	<ul style="list-style-type: none"> UP. Connect the positive pole to that of the downlink port of the previous switch, and the same for the negative pole. DOWN. Connect the positive pole to that of the uplink port of the subsequent switch, and the same for the negative pole.  <p>Under certain conditions, these two ports can be connected to the EOC port of a VTO, and you also need to connect the two positive poles together and the same for the negative poles.</p>



Before connecting cables, power off the switch first to avoid damaging it.

2.2 Rear Panel

Figure 2-2 Rear panel structure

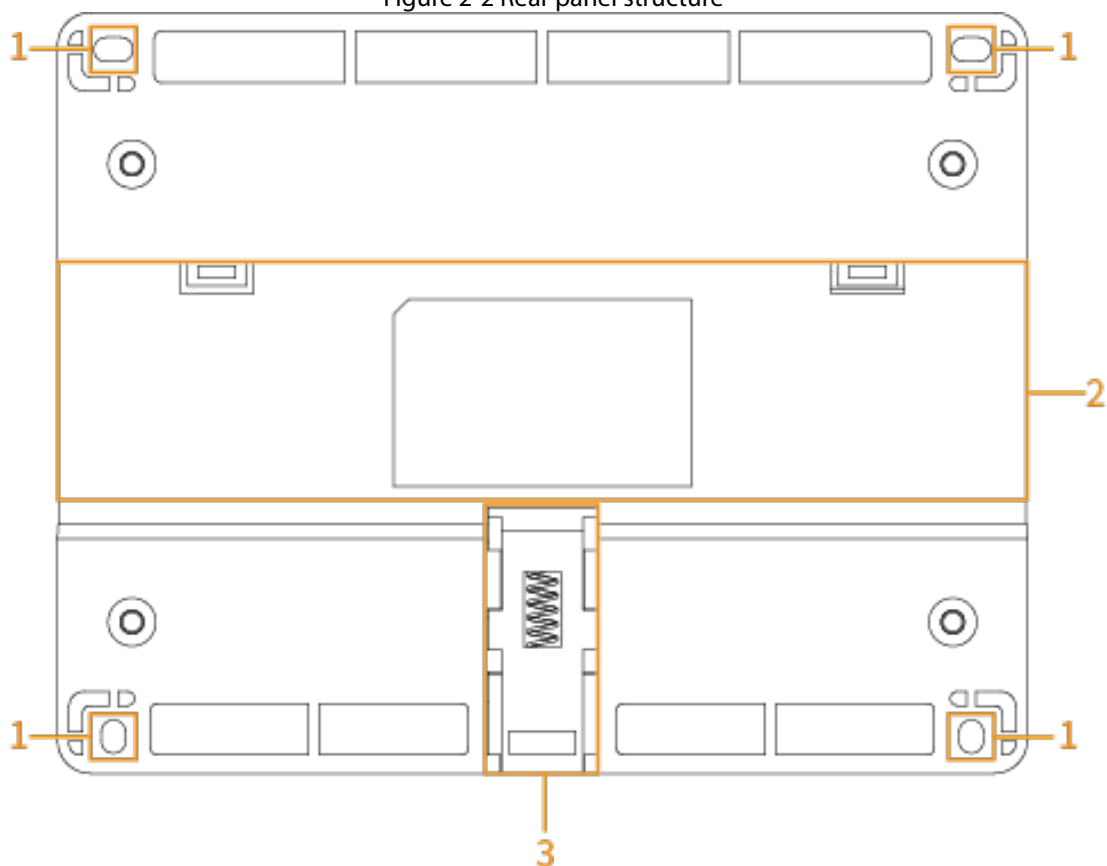

Table 2-2 Structure description

No.	Item	Description
1	Screw holes	Use four ST3 × 18-SUS to install the switch. See "4.1 Installing with Screws".
2	Rail	Use a guide rail to install the switch. See "4.2 Installing with Slide Rail".
3	Lower hook	Fix the switch when installing with a guide rail.

3 Installation

The chapter introduces how to install the switch on the wall with screws or a guide rail.

3.1 Installing with Screws

Use screws to fix the switch at a proper location on the wall.

Figure 3-1 Install the switch with screws

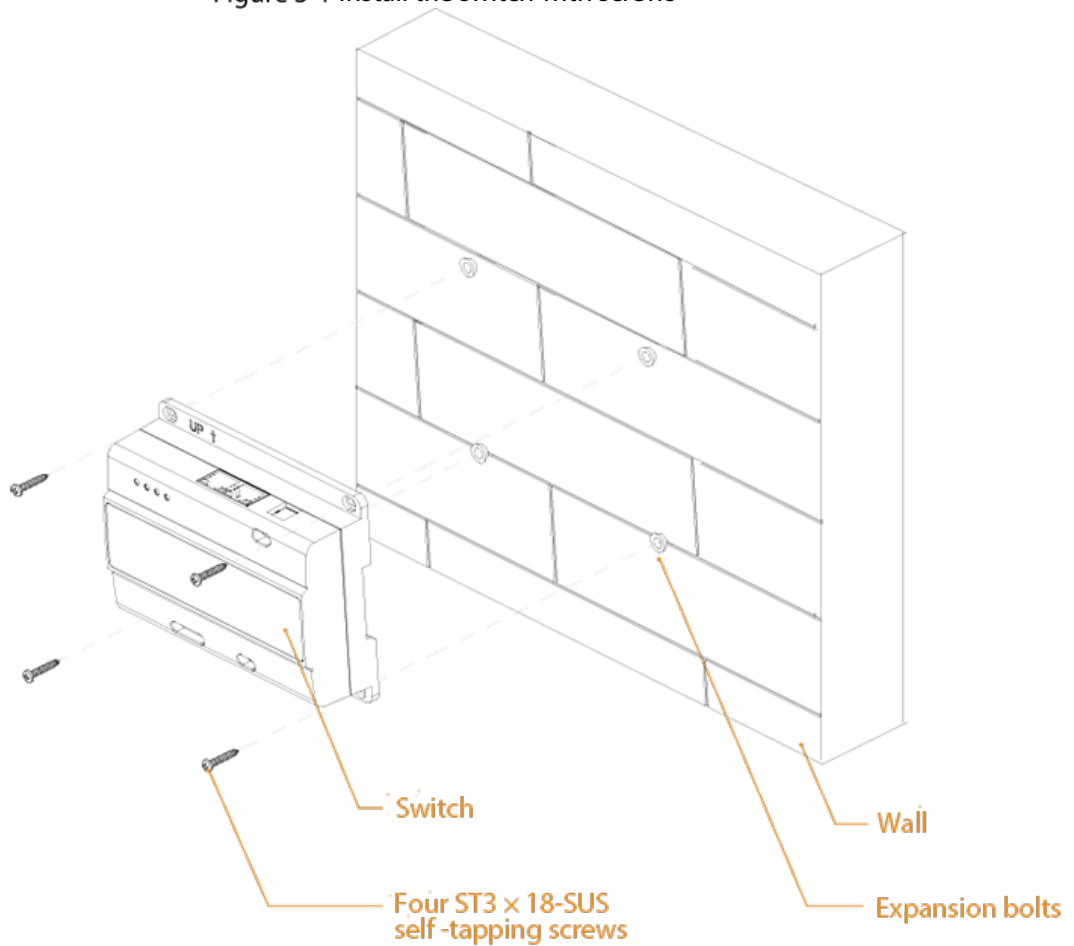

3.2 Installing with a Guide Rail

Preparation

Prepare a standard 35 mm guide rail.



The switch does not come with a guide rail.

Procedure

Step 1 Fix the guide rail at a proper location on the wall.

Figure 3-2 Install with a guide rail (1)

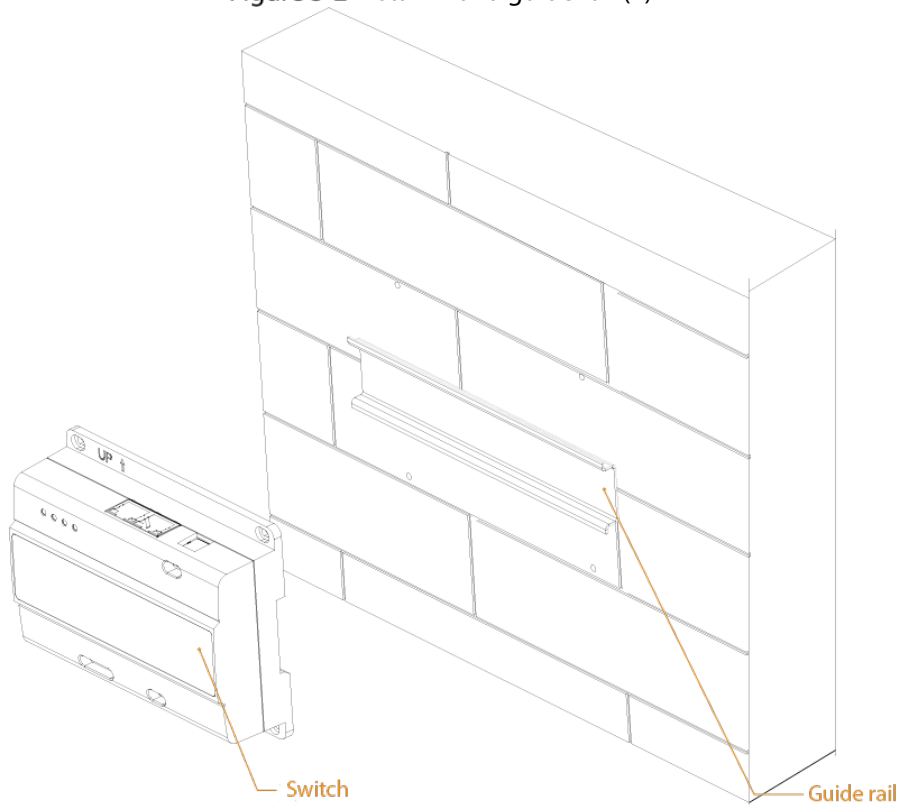

- Step 2** Fix the upper hooks inside the slot of the guide rail.
- Step 3** Pull down the lower hook and press the switch close to the guide rail.
- Step 4** Let go of the lower hook.

Figure 3-3 Install with a guide rail (2)

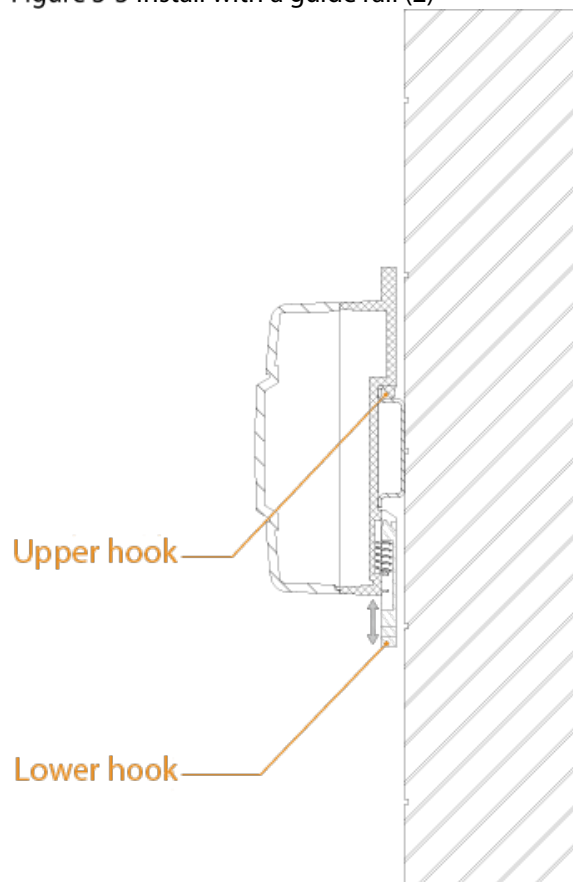

Appendix 1 Cybersecurity Recommendations

Cybersecurity is more than just a buzzword: it's something that pertains to every device that is connected to the internet. IP video surveillance is not immune to cyber risks, but taking basic steps toward protecting and strengthening networks and networked appliances will make them less susceptible to attacks. Below are some tips and recommendations on how to create a more secured security system.

Mandatory actions to be taken for basic device network security:

1. Use Strong Passwords

Please refer to the following suggestions to set passwords:

- The length should not be less than 8 characters;
- Include at least two types of characters; character types include upper and lower case letters, numbers and symbols;
- Do not contain the account name or the account name in reverse order;
- Do not use continuous characters, such as 123, abc, etc.;
- Do not use overlapped characters, such as 111, aaa, etc.;

2. Update Firmware and Client Software in Time

- According to the standard procedure in Tech-industry, we recommend to keep your device (such as NVR, DVR, IP camera, etc.) firmware up-to-date to ensure the system is equipped with the latest security patches and fixes. When the device is connected to the public network, it is recommended to enable the "auto-check for updates" function to obtain timely information of firmware updates released by the manufacturer.
- We suggest that you download and use the latest version of client software.

"Nice to have" recommendations to improve your device network security:

1. Physical Protection

We suggest that you perform physical protection to device, especially storage devices. For example, place the device in a special computer room and cabinet, and implement well-done access control permission and key management to prevent unauthorized personnel from carrying out physical contacts such as damaging hardware, unauthorized connection of removable device (such as USB flash disk, serial port), etc.

2. Change Passwords Regularly

We suggest that you change passwords regularly to reduce the risk of being guessed or cracked.

3. Set and Update Passwords Reset Information Timely

The device supports password reset function. Please set up related information for password reset in time, including the end user's mailbox and password protection questions. If the information changes, please modify it in time. When setting password protection questions, it is suggested not to use those that can be easily guessed.

4. Enable Account Lock

The account lock feature is enabled by default, and we recommend you to keep it on to guarantee the account security. If an attacker attempts to log in with the wrong password several times, the corresponding account and the source IP address will be locked.

5. Change Default HTTP and Other Service Ports

We suggest you to change default HTTP and other service ports into any set of numbers between 1024~65535, reducing the risk of outsiders being able to guess which ports you are using.

6. Enable HTTPS

We suggest you to enable HTTPS, so that you visit Web service through a secure communication channel.

7. MAC Address Binding

We recommend you to bind the IP and MAC address of the gateway to the device, thus reducing the risk of ARP spoofing.

8. Assign Accounts and Privileges Reasonably

According to business and management requirements, reasonably add users and assign a minimum set of permissions to them.

9. Disable Unnecessary Services and Choose Secure Modes

If not needed, it is recommended to turn off some services such as SNMP, SMTP, UPnP, etc., to reduce risks.

If necessary, it is highly recommended that you use safe modes, including but not limited to the following services:

- SNMP: Choose SNMP v3, and set up strong encryption passwords and authentication passwords.
- SMTP: Choose TLS to access mailbox server.
- FTP: Choose SFTP, and set up strong passwords.
- AP hotspot: Choose WPA2-PSK encryption mode, and set up strong passwords.

10. Audio and Video Encrypted Transmission

If your audio and video data contents are very important or sensitive, we recommend that you use encrypted transmission function, to reduce the risk of audio and video data being stolen during transmission.

Reminder: encrypted transmission will cause some loss in transmission efficiency.

11. Secure Auditing

- Check online users: we suggest that you check online users regularly to see if the device is logged in without authorization.
- Check device log: By viewing the logs, you can know the IP addresses that were used to log in to your devices and their key operations.

12. Network Log

Due to the limited storage capacity of the device, the stored log is limited. If you need to save the log for a long time, it is recommended that you enable the network log function to ensure that the critical logs are synchronized to the network log server for tracing.

13. Construct a Safe Network Environment

In order to better ensure the safety of device and reduce potential cyber risks, we recommend:

- Disable the port mapping function of the router to avoid direct access to the intranet devices from external network.
- The network should be partitioned and isolated according to the actual network needs. If there are no communication requirements between two sub networks, it is suggested to use VLAN, network GAP and other technologies to partition the network, so as to achieve the network isolation effect.
- Establish the 802.1x access authentication system to reduce the risk of unauthorized access to private networks.
- Enable IP/MAC address filtering function to limit the range of hosts allowed to access the device.