

DH-PFA135

Water-proof Junction Box



Features

- Neat & Integrated design.
- Material: Aluminum
- Water-proof Junction box

Technical Specifications

| | |
|-----------------------|----------------------------------|
| Model | DH-PFA135 |
| General | |
| Material | Aluminum |
| Dimension | φ90mmx34.1mm(φ3.54"x1.34") |
| Inch Thread | M20(G1/2") |
| Load Bearing | 1.0kg(2.2lb) |
| Weight | 0.16kg(0.35lb) |
| Color | White |
| Operating Temperature | -40°C~+60°C(-40°F ~+140°F) |
| Humidity | 0~90% RH |
| Applicable Model | Please see "Accessory Selection" |

Order Information

| Type | Part Number | Description |
|--------------|-------------|---|
| Camera mount | DH-PFA135 | Water-proof Junction box _ Dahua brand |
| | PFA135 | Water-proof Junction box _ Neutral, no brand |

Dimensions (mm/inch)

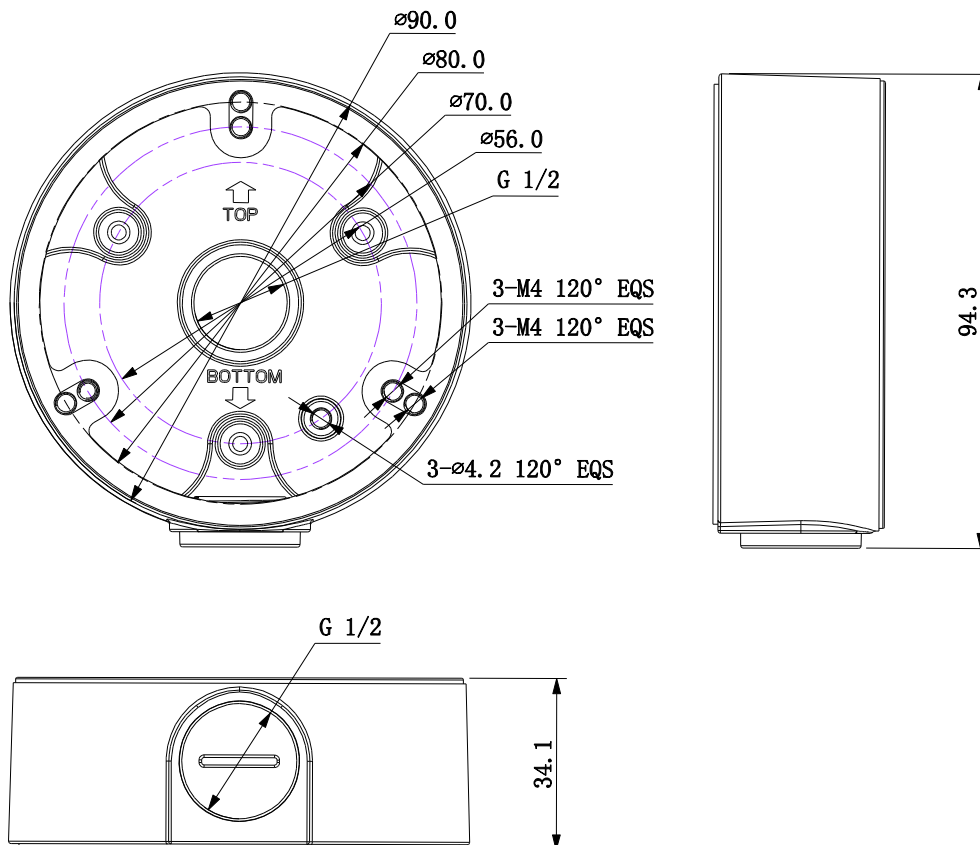

Application

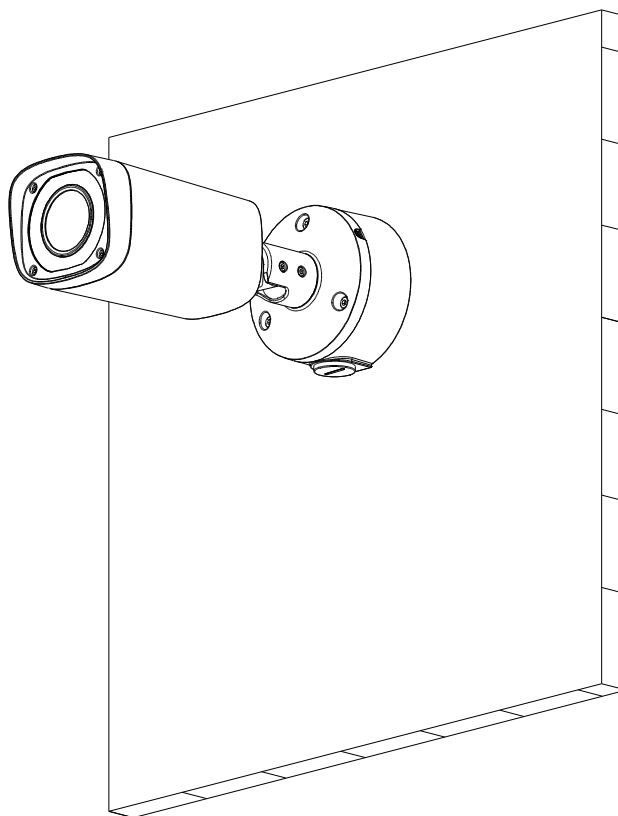

Package Information

- Water-proof junction box *1
- M4x10 screw *3
- ST4x25 screw *3
- Plastic anchor *3
- Water Joint *1
- Wrench *1

| Package data | |
|--------------------------|--|
| Box Dimension | 115mmx115mmx45mm(4.53"x4.53"x1.77") |
| Box Weight | 0.2kg (0.44lb) |
| Protective Box Dimension | 523mmx497mmx140mm(20.59"x19.57"x5.51") |
| Box In Protective Box | 40 In 1 |