

TruVision People Counting Camera Quick Installation Guide

- DE TruVision-Kamera für Personenzählung – Schnellinstallationsanleitung
- ES Guía de instalación rápida de la cámara de recuento de personas TruVision
- FR Guide d'installation rapide de la caméra pour comptage de personnes TruVision
- IT Guida all'installazione rapida della telecamera conta persone TruVision
- NL Snelle installatiegids TruVision Personen tellen-camera
- PL Skrócona instrukcja instalacji kamery do liczenia osób TruVision
- PT Guia de instalação rápida da câmara de contagem de pessoas TruVision
- RU Краткое руководство по установке камеры TruVision для подсчета людей
- TR TruVision Kişi Sayma Kamerası Hızlı Kurulum Kılavuzu

© 2021 Carrier. All rights reserved. Specifications subject to change without prior notice.

TruVision names and logos are a product brand of Aritech, a part of Carrier. Other trade names used in this document may be trademarks or registered trademarks of the manufacturers or vendors of the respective products.

Product warnings and disclaimers: THESE PRODUCTS ARE INTENDED FOR SALE TO AND INSTALLATION BY QUALIFIED PROFESSIONALS. CARRIER FIRE & SECURITY CANNOT PROVIDE ANY ASSURANCE THAT ANY PERSON OR ENTITY BUYING ITS PRODUCTS, INCLUDING ANY "AUTHORIZED DEALER" OR "AUTHORIZED RESELLER", IS PROPERLY TRAINED OR EXPERIENCED TO CORRECTLY INSTALL FIRE AND SECURITY RELATED PRODUCTS.

For more information on warranty disclaimers and product safety information, please check www.firesecurityproducts.com/policy/product-warning/ or scan the following code:



Please consult the following web link to retrieve the electronic version of the product documentation. The manuals are available in several languages.



**TVS-PC1: Outdoor camera / Außenkamera / Cámara exterior /
 Caméra d'extérieur / Telecamera per esterni / Buitencamera /
 Kamera zewnętrzna / Câmara exterior / Камеры для
 использования на улице / Diş mekan kamerası**

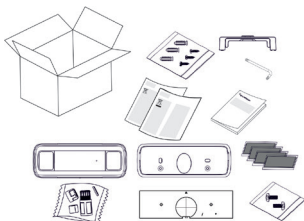

**TVS-PC2: Indoor camera / Innenkamera / Cámara interior /
 Caméra d'intérieur / Telecamera per interni / Binnencamera /
 Kamera wewnętrzna / Câmara interior / Камеры для
 использования в помещении / İç mekan kamerası**

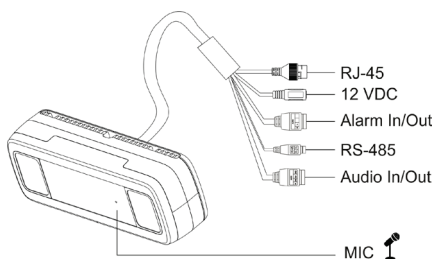

Installation guidelines

Installationsanleitung / Instrucciones de instalación / Instructions d'installation / Linee guida all'installazione / Wskazówki dotyczące instalacji / Diretrizes de instalação / Руководство по установке / Kurulum yönergeleri

EN: The camera's counting zone width (A) depends on its mounting height (B). The recommended installation height for the camera is less than 4.0 m

DE: Die Breite des Zählbereichs (A) der Kamera ist von der Installationshöhe (B) abhängig. Die empfohlene Installationshöhe der Kamera beträgt unter 4,0 m.

ES: La anchura de recuento de la cámara (A) depende de su altura de instalación (B). La altura de instalación recomendada para la cámara es inferior a 4,0 m.

FR : La largeur de comptage (A) de la caméra dépend de sa hauteur d'installation (B). Il est conseillé de l'installer à moins de 4 mètres de hauteur.

IT : La larghezza di conteggio della telecamera (A) dipende dalla sua altezza di installazione (B). L'altezza di installazione consigliata per la telecamera è inferiore a 4,0 m.

NL : De breedte (A) waarbinnen de camera kan tellen is afhankelijk van de hoogte (B) waarop zij wordt geïnstalleerd. Aanbevolen wordt om de camera niet hoger dan 4,0 m te installeren

PL: Szerokość liczenia (A) zależy od wysokości mocowania kamery (B). Zalecana wysokość montażu kamery wynosi poniżej 4 m.

PT: A largura de contagem (A) da câmara depende da respetiva altura de instalação (B). A altura de instalação recomendada para a câmara é inferior a 4,0 m.

RU: Ширина области захвата для подсчета людей (A) зависит от высоты установки камеры (B). Рекомендуемая высота установки для камеры - не более 4,0 м.

TR: Kameranın kişi sayma genişliği (A), kurulum yüksekliğine (B) bağlıdır. Kamera için önerilen kurulum yüksekliği 4,0 m'nin altıdır.

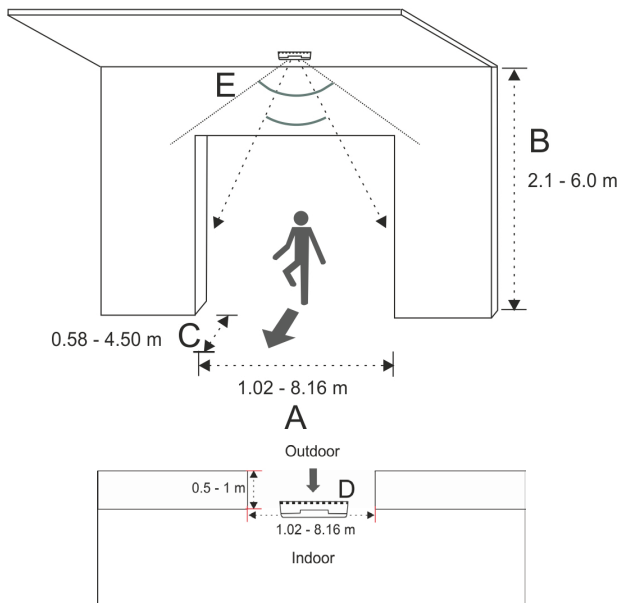

EN	A = People counting zone width (m) B = Camera mounting height (m) C = People counting zone depth (m) D = Mounting position (m) 9 E = Field of view (m)	DE	A = Breite des Personenzählbereichs (m) B = Montagehöhe der Kamera (m)/ C = Tiefe des Personenzählbereichs (m) D = Montageposition (m) E = Sichtfeld (m)
ES	A = Anchura de zona de recuento de personas (m) B = Altura de montaje de la cámara (m) C = Profundidad de zona de recuento de personas (m) D = Posición de montaje (m) E = Campo de visión (m)	FR	A = Largeur de la zone de comptage de personnes (m) B = Hauteur de montage de la caméra (m) C = Profondeur de la zone de comptage de personnes (m) D = Position de montage (m) E = Champ de vision (m)
IT	A = Larghezza zona di conteggio persone (m)	NL	A = Zonebreedte personen tellen (m) B = Montagehoogte camera (m)

	<p>B = Altezza di montaggio della telecamera (m) C = Larghezza zona di conteggio persone (m) D = Posizione di montaggio (m) E = Campo di visualizzazione (m)</p>		<p>C = Zonediepte personen tellen (m) D = Montagepositie (m) E = Weergaveveld (m)</p>
PL	<p>A = Szerokość strefy liczenia osób (m) B = Wysokość mocowania kamery (m) C = Głębokość strefy liczenia osób (m) D = Pozycja mocowania (m) E = Pole widzenia (m)</p>	PT	<p>A = Largura da zona de contagem de pessoas (m) B = Altura de montagem da câmara (m) C = Profundidade da zona de contagem de pessoas (m) D = Posição de montagem (m) E = Campo de visão (m)</p>
RU	<p>A = Ширина области для подсчета (м) B = Высота установки камеры (м) C = Глубина области для подсчета (м) D = Положение при установке (м) E = Поле обзора (м)</p>	TR	<p>A = Kişi sayma bölgesi genişliği (m) B = Kamera montaj yüksekliği (m) C = Kişi sayma bölgesi derinliği (m) D = Montaj konumu (m) E = Görüş alanı (m)</p>

A (m)	B (m)	C (m)
1.02	2.1	0.58
1.28	2.2	0.72
1.54	2.3	0.86
1.79	2.4	1.01
2.05	2.5	1.15
2.30	2.6	1.30
2.56	2.7	1.44
2.82	2.8	1.58
3.07	2.9	1.73
3.33	3.0	1.87
3.58	3.1	2.02

A (m)	B (m)	C (m)
6.14	4.1	3.46
6.4	4.2	3.60
6.66	4.3	3.74
6.91	4.4	3.89
7.17	4.5	4.03
5.50	4.6	3.08
5.69	4.7	3.19
5.88	4.8	3.30
6.07	4.9	3.40
6.26	5.0	3.51
6.45	5.1	3.62

A (m)	B (m)	C (m)
3.84	3.2	2.16
4.10	3.3	2.30
4.35	3.4	2.45
4.61	3.5	2.59
4.86	3.6	2.74
5.12	3.7	2.88
5.38	3.8	3.02
5.63	3.9	3.17
5.89	4.0	3.31

A (m)	B (m)	C (m)
6.64	5.2	3.72
6.83	5.3	3.83
7.02	5.4	3.93
7.21	5.5	4.04
7.40	5.6	4.15
7.59	5.7	4.25
7.78	5.8	4.36
7.97	5.9	4.47
8.16	6.0	4.50

1

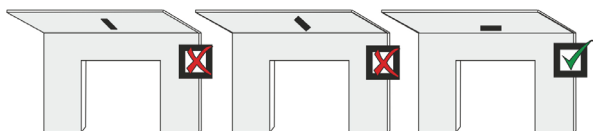

2

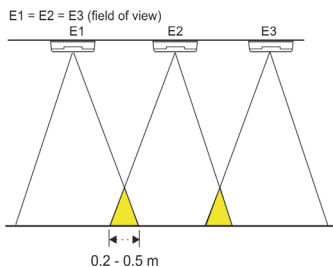

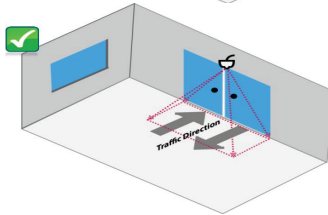
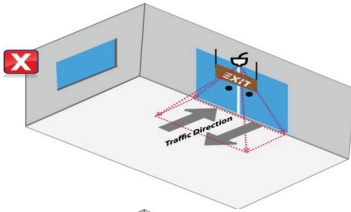
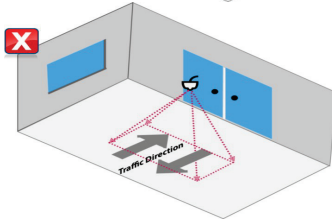
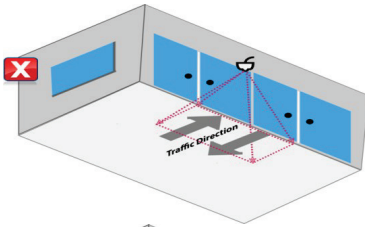

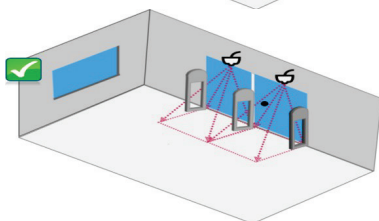
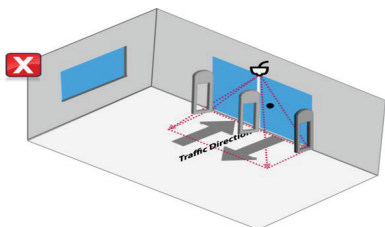

Mounting the camera

Montieren der Kamera / Montaje de la cámara /
Montage de la caméra / Montaggio della
telecamera / De camera monteren / Mocowanie
kamery / Montagem da câmara / Монтаж камеры /
Kamerayı monte etme

1

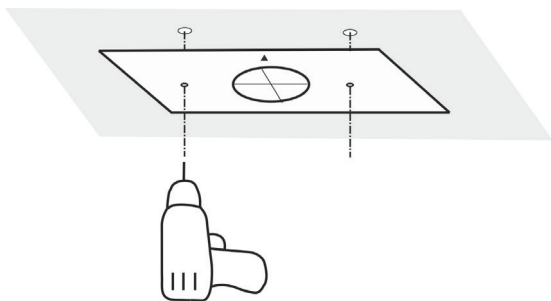

2

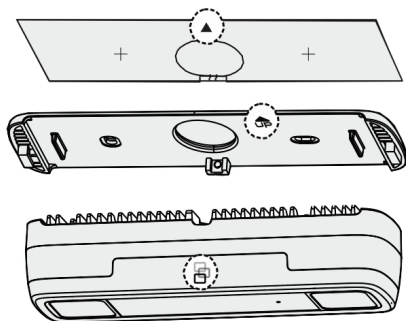

3

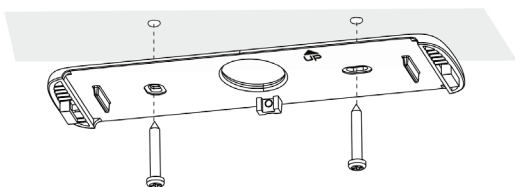

4

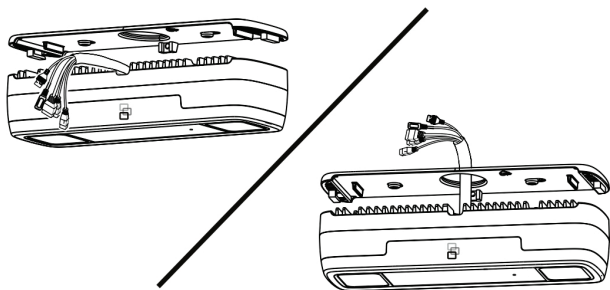

5

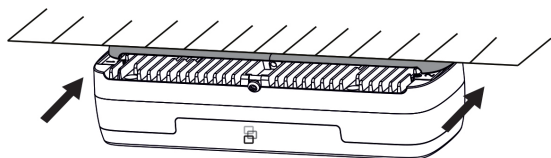

6

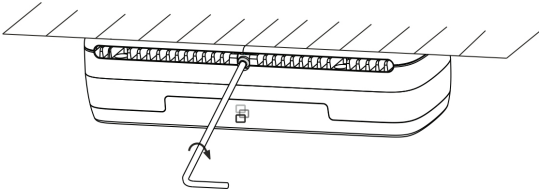

7 Optional / Optional / Opzioneel / Optionnel / Opzionale / Opzioneel /
/ Opcjonalny / Opcjonal / По желанию / İsteğe bağı

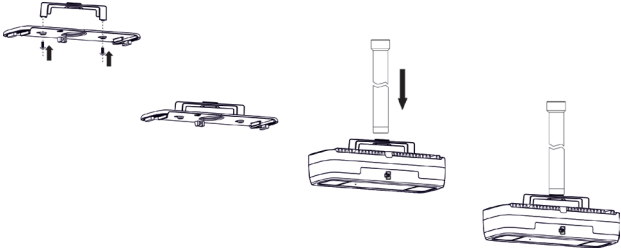

8





<https://firesecurityproducts.com/en/products/video/cameras>

EN

Installation environment

When installing your product, consider these factors:

- **Electrical:** Install electrical wiring carefully. It should be done by qualified service personnel. Always use a proper PoE switch, a 12 VDC UL listed Class 2, or CE certified power supply to power the camera. Do not overload the power cord or adapter.
- **Ventilation:** Ensure that the location planned for the installation of the camera is well ventilated.
- **Temperature:** Do not operate the camera beyond the specified temperature, humidity or power source ratings. The operating temperature of the indoor camera is between -30 °C to +60 °C. Humidity 95% or

less (non-condensing) for the camera.

- **Moisture:** Do not expose the camera to rain or moisture, or try not to operate it in wet areas. Turn the power off immediately if the camera is wet and ask a qualified service person for servicing. Moisture can damage the camera and also create the danger of electric shock.
- **Servicing:** Do not attempt to service this camera yourself. Refer all servicing to qualified service personnel.

Specifications

Electrical

Voltage input	12 VDC, PoE (IEEE 802.3af)
---------------	-------------------------------

Power consumption	Max. 8.0 W
-------------------	------------

Miscellaneous

Focal length	2 mm
--------------	------

Connectors	Network Port(PoE), Audio In/Out, Alarm In/Out, RS-485 Port
Operating temperature	-30 to +60 °C
Dimensions	168 x 61 x 41 mm (TVS-PC1) 168 x 61 x 36 mm (TVS-PC2)
Weight	435 g
Environmental rating	IP67 (TVS-PC1)

DE

Installationsumgebung

Beachten Sie beim Installieren des Produkts folgende Faktoren:

- **Elektrik:** Gehen Sie bei der Installation von elektrischen Leitungen sorgfältig um. Die Installation darf nur von geschultem Fachpersonal durchgeführt werden. Schließen Sie diese Kamera ausschließlich an einen ordnungsgemäßen PoE-Switch oder an ein in der UL-Liste eingetragenes 12-V-Gleichstrom-Netzteil der Klasse 2 oder mit CE-Zulassung an. Schützen Sie Netzkabel und Netzteil vor Überspannung.
- **Belüftung:** Stellen Sie sicher, dass der für die Installation des

Geräts vorgesehene Standort gut belüftet ist.

- **Temperatur:** Nehmen Sie die Kamera nicht in Betrieb, wenn die Werte für Temperatur, Luftfeuchtigkeit oder die Stromquelle außerhalb des angegebenen Bereichs liegen. Die Betriebstemperatur der Kamera liegt zwischen -30 °C und +60 °C. Die maximale Luftfeuchtigkeit für die Kamera beträgt 95 % (nicht kondensierend).
- **Feuchtigkeit:** Setzen Sie die Kamera weder Regen noch Feuchtigkeit aus und nehmen Sie sie nicht in Nassbereichen in Betrieb. Trennen Sie die Kamera bei Nässe/Feuchtigkeit unmittelbar von der Stromversorgung, und bitten Sie geschultes Fachpersonal um Wartung. Durch Feuchtigkeit kann die Kamera beschädigt werden und die Gefahr eines elektrischen Schlags bestehen.
- **Wartung:** Versuchen Sie nicht, das Gerät selbst zu warten. Überlassen Sie die Wartung geschultem Fachpersonal.

Spezifikationen

Elektrik

Eingangsspannung	12 V DC, PoE (IEEE 802.3af)
------------------	-----------------------------

Leistungsaufnahme	Max. 8,0 W
-------------------	------------

Weitere Angaben

Brennweite	2 mm
------------	------

Anschlüsse	Netzwerkport (PoE), Audio In/Out, Alarm In/Out, RS-485-Port
------------	---

Betriebstemperatur	-30 bis +60 °C
--------------------	----------------

Abmessungen	168 × 61 × 41 mm (TVS-PC1)
	168 × 61 × 36 mm (TVS-PC2)

Gewicht	435 g
---------	-------

Schutzart	IP67 (TVS-PC1)
-----------	----------------

ES

Entorno de instalación

Cuando instale el producto, tenga en cuenta los siguientes factores:

- **Electricidad:** instale con cuidado el cableado eléctrico. La instalación debe realizarla personal de servicio cualificado. Utilice siempre para la cámara un switch PoE adecuado, una fuente de alimentación de 12 V CC con la marca UL de clase 2 o una fuente de alimentación

con la certificación CE. No sobrecargue el cable o el adaptador de alimentación.

- **Ventilación:** asegúrese de que la ubicación prevista para instalar la cámara esté bien ventilada.
- **Temperatura:** no ponga en funcionamiento la cámara por encima de la temperatura, humedad o intensidad de la fuente de alimentación especificadas. La temperatura de funcionamiento de la cámara está comprendida entre -30 y +60 °C. 95 % de humedad o inferior (sin condensación) para la cámara.
- **Humedad:** no exponga la cámara a la lluvia o la humedad, ni intente ponerla en funcionamiento en zonas húmedas. Desconecte la alimentación inmediatamente si la cámara está húmeda y solicite a un técnico cualificado la revisión de la unidad. La humedad puede dañar la cámara y generar riesgo de descarga eléctrica.
- **Mantenimiento:** no intente realizar operaciones de mantenimiento por su cuenta en la cámara. Encargue todas las tareas de mantenimiento a personal de servicio cualificado.

Especificaciones

Electricidad:

Entrada de voltaje	12 V CC, PoE (IEEE 802.3af)
--------------------	-----------------------------

Consumo de energía	Máx. 8,0 W
--------------------	------------

Varios

Distancia focal	2 mm
-----------------	------

Conectores	Puerto de red (PoE), entrada/salida de audio, entrada/salida de alarma y puerto RS-485
------------	--

Temperatura de funcionamiento	De -30 a +60 °C
-------------------------------	-----------------

Dimensiones	168 × 61 × 41 mm (TVS-PC1) 168 × 61 × 36 mm (TVS-PC2)
-------------	--

Peso	435 g
------	-------

Clasificación medioambiental	IP67 (TVS-PC1)
------------------------------	----------------

FR

Environnement d'installation

Tenez compte des éléments suivants lors de l'installation du produit :

- **Facteurs électriques** : faites preuve de prudence lors de tout câblage électrique. Cette opération doit être exécutée par

une personne qualifiée. Utilisez toujours un commutateur PoE approprié ou une alimentation 12 Vcc aux normes UL de classe 2 ou certifiée CE pour alimenter la caméra.

N'appliquez pas une charge excessive au niveau du cordon d'alimentation ou de l'adaptateur.

- **Ventilation** : assurez-vous que le lieu dans lequel la caméra est installée est bien aéré.
- **Température** : ne faites pas fonctionner la caméra lorsque la température, le taux d'humidité ou la source d'alimentation n'est pas adapté(e). La température de fonctionnement de la caméra est comprise entre -30 et 60°C. Humidité inférieure ou égale à 95 % (sans condensation) pour la caméra.
- **Humidité** : n'exposez pas la caméra à la pluie ou à l'humidité, et ne tentez pas de l'utiliser dans des zones humides. Éteignez immédiatement la caméra si celle-ci est entrée en contact avec de l'eau, et adressez-vous à une personne qualifiée pour sa réparation. L'humidité peut endommager la caméra et occasionner des électrocutions.
- **Réparation** : ne tentez pas de réparer vous-même la caméra. Les réparations doivent être effectuées par une personne qualifiée.

Caractéristiques techniques

Caractéristiques électriques

Tension d'entrée	12 VDC, PoE (IEEE 802.3af)
------------------	----------------------------

Consommation énergétique	Max. 8 W
--------------------------	----------

Divers

Distance focale	2 mm
-----------------	------

Connecteurs	Port réseau (PoE), entrée/sortie audio, entrée/sortie alarme, port RS-485
-------------	--

Température de fonctionnement	-30 à +60 °C
-------------------------------	--------------

Dimensions	168 x 61 x 41 mm (TVS-PC1)
	168 x 61 x 36 mm (TVS-PC2)

Poids	435 g
-------	-------

Classe environnementale	IP67 (TVS-PC1)
-------------------------	----------------

IT

Ambiente di installazione

Durante l'installazione del prodotto, tenere in considerazione i seguenti fattori:

- **Caratteristiche elettriche:** installare il cablaggio elettrico con attenzione. Questa operazione deve essere

effettuata da personale di assistenza qualificato. Utilizzare sempre uno switch PoE appropriato o un alimentatore di classe 2 conforme a UL o certificato CE a 12 VCC o per l'alimentazione della telecamera. Non sovraccaricare il cavo di alimentazione o l'adattatore.

- **Ventilazione:** assicurarsi che il luogo previsto per l'installazione dell'unità sia ben aerato.
- **Temperatura:** non mettere in funzione la telecamera oltre i valori nominali di temperatura, umidità o sorgente di alimentazione specificati. La temperatura di funzionamento della telecamera è compresa tra -30 °C e +60 °C. Umidità al 95% o inferiore (senza condensa) per la telecamera.
- **Umidità:** non esporre la telecamera alla pioggia o all'umidità, né utilizzarla in ambienti umidi. Se la telecamera è umida, spegnerla immediatamente e richiedere assistenza a personale tecnico qualificato. L'umidità può danneggiare la telecamera, nonché causare un pericolo di scosse elettriche.
- **Manutenzione e riparazione:** non tentare di effettuare autonomamente interventi di manutenzione e riparazione della telecamera. Per tutti gli interventi di manutenzione,

rivolgersi a personale qualificato.

Specifiche

Caratteristiche elettriche

Ingresso di tensione	12 VCC, PoE (IEEE 802.3af)
----------------------	----------------------------

Consumo energetico	Max. 8,0 W
--------------------	------------

Varie

Lunghezza focale	2 mm
------------------	------

Connettori	Porta di rete (PoE), ingresso/uscita audio, allarme in ingresso/uscita, porta RS-485
------------	--

Temperatura di funzionamento	da -30 a +60 °C
------------------------------	-----------------

Dimensioni	168 × 61 × 41 mm (TVS-PC1)
	168 × 61 × 36 mm (TVS-PC2)

Peso	435 g
------	-------

Classificazione e ambientale	IP67 (TVS-PC1)
------------------------------	----------------

NL

Installatieomgeving

Tijdens het installeren van uw product moet u rekening houden met het volgende:

- **Elektrische bedrading:** Installeer de elektrische bedrading voorzichtig. Laat de installatie uitvoeren door gekwalificeerd onderhoudspersoneel. Gebruik altijd een geschikte PoE-schakelaar, een 12V gelijkstroom of UL Klasse 2 of CE-gecertificeerde voedingsbron voor de voeding van de camera. Overbelast de voedingskabel of adapter niet.
- **Ventilatie:** Zorg dat de installatielocatie van de camera goed geventileerd is.
- **Temperatuur:** Gebruik de camera niet indien de opgegeven waarden voor temperatuur, vochtigheid of voedingsbron worden overschreden. De bedrijfstemperatuur van de camera ligt tussen -30 °C en +60 °C. Vochtigheid 95% of minder (niet-condenserend) voor de camera.
- **Vocht:** Stel de camera niet bloot aan regen of vocht, en gebruik de camera niet in natte omgevingen. Schakel de voeding direct uit als de camera nat is en vraag gekwalificeerde onderhoudspersoneel om de camera na te kijken. Vocht kan de camera beschadigen en elektrische schokken veroorzaken.
- **Onderhoud:** Probeer nooit zelf onderhoud aan de camera uit te voeren. Laat al het onderhoud

over aan gekwalificeerd
onderhoudspersoneel.

Specificaties

Elektrisch

Ingangsspanning 12 VDC, PoE (IEEE
802.3af)

Stroomverbruik Max. 8,0 W

Diverse

Focusbereik 2 mm

Aansluitingen Netwerkpoort
(PoE), audio in/uit,
alarm in/uit, RS-485
V-poort

Bedrijfstemperatuur -30 tot +60 °C

Afmetingen 168 × 61 × 41 mm
(TVS-PC1)
168 x 61 x 36 mm
(TVS-PC2)

Gewicht 435 g

Milieuclassificatie IP67 (TVS-PC1)

PL

Warunki instalacji

Podczas instalowania produktu
należy rozważyć następujące
czynniki:

- **Parametry elektryczne:** należy zachować ostrożność podczas instalowania okablowania elektrycznego. Ta czynność musi zostać wykonana przez wykwalifikowany personel. W celu zasilania kamery należy

zawsze używać odpowiedniego przełącznika PoE bądź zasilacza 12 V (prąd stały) klasy 2 uznawanych przez UL lub mających certyfikat CE. Nie wolno przeciążać przewodu zasilającego ani zasilacza.

- **Wentylacja:** należy upewnić się, że miejsce planowanej instalacji jest dobrze wentylowane.
- **Temperatura:** nie wolno używać kamery w warunkach innych niż podane (dotyczy to danych znamionowych temperatury, wilgotność i źródła zasilania). Zakres temperatury pracy kamery wynosi od -30°C do +60°C. Wilgotność 95% lub mniej (bez kondensacji) dla kamery.
- **Wilgoć:** nie wolno narażać kamery na działanie wilgoci lub deszczu ani używać jej w wilgotnym obszarze. Należy natychmiast wyłączyć zasilanie, jeśli kamera jest morka i poprosić wykwalifikowanego technika o serwisowanie. Wilgoć może spowodować uszkodzenie kamery, a także stworzyć zagrożenie porażenia prądem elektrycznym.
- **Serwis:** nie należy podejmować prób samodzielnego wykonywania czynności serwisowych kamery. Wszystkie czynności serwisowe muszą zostać wykonane przez wykwalifikowany personel serwisowy.

Dane techniczne

Parametry elektryczne

Napięcie wejściowe	12 V, prąd stały, PoE (IEEE 802.3af)
--------------------	--------------------------------------

Pobór mocy	Maks. 8,0 W
------------	-------------

Inne

Długość ogniskowej	2 mm
--------------------	------

Złącza	Port sieciowy (PoE), wejście/wyjście audio, wejście/wyjście alarmu, port RS-485
--------	---

Temperatura pracy	Od -30 do +60°C
-------------------	-----------------

Wymiary	168 × 61 × 41 mm (TVS-PC1) 168 × 61 × 36 mm (TVS-PC2)
---------	--

Masa	435 g
------	-------

Klasa środowiskowa	IP67 (TVS-PC1)
--------------------	----------------

PT

Ambiente de instalação

Ao instalar o produto, tenha em atenção os seguintes factores:

- **Eléctricos:** instale os fios eléctricos cuidadosamente.

Deve ser efectuado por pessoal qualificado. Para alimentação da câmara, utilize sempre um comutador PoE adequado ou uma fonte de alimentação de 12 V CC listada na UL como Classe 2 ou com certificação CE. Não sobrecarregar o cabo ou adaptador de alimentação.

- **Ventilação:** certifique-se de que a localização prevista para a instalação da câmara é bem ventilada.
- **Temperatura:** não opere a câmara para além das especificações de temperatura, de humidade ou de fonte de alimentação. A temperatura de funcionamento da câmara situa-se entre -30 e +60 °C. Humidade de 95% ou inferior (sem condensação) para a câmara.
- **Humidade:** não exponha a câmara à chuva ou à humidade, nem tente operá-la em áreas molhadas. Desligue imediatamente a alimentação caso a câmara esteja molhada e solicite assistência a pessoal qualificado. A humidade pode danificar a câmara e, além disso, colocar o perigo de choque eléctrico.
- **Reparação:** não tente efectuar manutenção na câmara. Remeta toda a assistência para pessoal qualificado.

Especificações

Elétricas

Entrada de tensão	12 VCC, PoE (IEEE 802.3af)
-------------------	----------------------------

Consumo de energia	Máx. 8,0 W
--------------------	------------

Diversos

Comprimento focal	2 mm
-------------------	------

Conectores	Porta de rede (PoE), entrada/saída de áudio, entrada/saída de alarme, porta RS-485
------------	--

Temperatura de funcionamento	-30 a +60 °C
------------------------------	--------------

Dimensões	168 x 61 x 41 mm (TVS-PC1)
	168 x 61 x 36 mm (TVS-PC2)

Peso	435 g
------	-------

Classificação ambiental	IP67 (TVS-PC1)
-------------------------	----------------

RU

Среда установки

При установке изделия необходимо учитывать следующие факторы:

- **Электрические:** Соблюдайте осторожность при электрическом подключении камеры. Этой работой должен заниматься квалифицированный персонал. Всегда используйте надлежащий коммутатор PoE или подключайте камеру к источникам электропитания на 12 В постоянного тока, соответствующим сертификату безопасности UL (Класс 2) или CE. Не перегружайте сетевой шнур или блок питания.
- **Вентиляция:** Убедитесь, что место, предназначенное для установки камеры, хорошо проветривается.
- **Температура.** Запрещается использовать камеру, если температура, уровень влажности и параметры электропитания находятся вне указанных допустимых пределов. Диапазон рабочих температур камеры: от -30°C до +60°C. Уровень влажности для камеры: не более 95% (без конденсации).
- **Влажность:** На камеру не должны попадать дождь или влага, рекомендуется не использовать камеру в сырых помещениях. При образовании влаги на камере немедленно выключите ее и обратитесь к квалифицированному техническому специалисту. Влага может повредить

камеру и создать угрозу поражения электрическим током.

- **Обслуживание:** Не пытайтесь сами отремонтировать камеру. Все ремонтные работы должны выполняться квалифицированным персоналом.

Характеристики

Электротехнические характеристики

Входное напряжение	12 В пост. тока, PoE (IEEE 802.3af)
--------------------	-------------------------------------

Энергопотребление	Макс 8,0 Вт
-------------------	-------------

Прочие характеристики

Фокусное расстояние	2 мм
---------------------	------

Разъемы	Сетевой порт (PoE), аудиовход/выход, тревожный вход/выход, порт RS-485
---------	--

Рабочая температура	-30 до +60 °C
---------------------	---------------

Размеры	168 × 61 × 41 мм (TVS-PC1) 168 × 61 × 36 мм (TVS-PC2)
---------	--

Вес	435 г
-----	-------

Степень защиты	IP67 (TVS-PC1)
----------------	----------------

TR

Kurulum ortamı

Ürününüzü kurarken, şu faktörleri göz önünde bulundurun:

- **Elektriksel:** Elektrik kablolarını dikkatlice bağlayın. Yetkili servis personeli tarafından yapılması gerekir. Kameraya enerji vermek için daima uygun bir PoE anahtarı veya UL onaylı Sınıf 2 ya da CE onaylı bir 12 VDC güç kaynağı kullanın. Güç kablosuna ya da adaptöre aşırı yüklemeyin.
- **Havalandırma:** Kameranın kurulumu için planlanan alanın iyi şekilde havalandırıldığından emin olun.
- **Sıcaklık:** Kamerayı belirtilen sıcaklık, nem veya güç kaynağı değerlerinin dışında çalıştırmayın. Kameranın çalışma sıcaklığı -30°C ile +60°C arasındadır. Kameranın çalıştırılacağı ortamın nem oranı %95 (yoğuşmasız) veya altında olmalıdır.
- **Rutubet:** Kamerayı yağmura veya rutubete maruz bırakmayın ya da ıslak alanlarda çalıştırmayı denemeyin. Kamera ıslanırsa hemen kapatın ve yetkili bir servis elemanının bakıma almasını isteyin. Rutubet kameraya zarar verebilir ve

ayrıca elektrik çarpması tehlikesi oluşturabilir.

- **Bakım:** Kamerası kendi başınıza bakım yapmaya kalkmayın. Tüm bakım işlemlerini yetkili servis personeline yönlendirin.

Teknik Özellikler

Elektrikle ilgili

Voltaj girişi 12 VDC, PoE
(IEEE 802.3af)

Güç tüketimi Maks. 8,0 W

Çeşitli

Odak uzunluğu 2 mm

Konektörler Ağ Portu(PoE),
Ses Girişi/Çıkışı,
Alarm
Girişi/Çıkışı, RS-
485 Portu

Çalışma sıcaklığı -30°C ila 60°C

Boyutlar 168 x 61 x 41
mm (TVS-PC1)
168 x 61 x 36
mm (TVS-PC2)

Ağırlık 435 g

Koruma sınıfı IP67 (TVS-PC1)

