

Skin Cover

SBC-165W

Tilt Mount

SBS-165TM

Flush Mount

SHS-165F



Package (SBS-165TM)

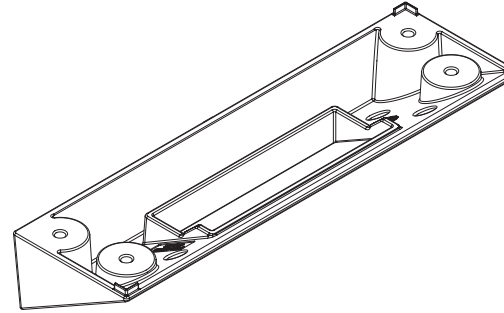

TILT MOUNT



SCREW 2EA

Product Overview

- ENG** ■ SBC-165W is a skin cover with which the color of TID-600R Intercom can be changed to white.
- SBS-165TM is a mount for installing the TID-600R Intercom on a wall at the tilted angle of 30°.
- SHS-165F is a mount for installing the TID-600R Intercom camera in a buried type.

- FRA** ■ SBC-165W est un couvercle de protection qui permet de changer la couleur de l'interphone TID-600R en blanc.
- Le SBS-165TM est un support permettant d'installer l'interphone TID-600R sur un mur avec un angle d'inclinaison de 30°.
- SHS-165F est un support permettant d'installer la caméra d'interphone TID-600R dans un type encastré.

- SPA** ■ SBC-165W es una cubierta superficial con la que se puede cambiar el color del intercomunicador TID-600R a blanco.
- El SBS-165TM es un soporte para la instalación del intercomunicador TID-600R en una pared con un ángulo de inclinación de 30°.
- SHS-165F es un soporte para la instalación de la cámara del intercomunicador TID-600R de tipo empotrado.

- GER** ■ SBC-165W ist eine Abdeckhaut, mit der die Farbe der TID-600R Intercom in weiß geändert werden kann.
- SBS-165TM ist eine Befestigung für die Installation der TID-600R Intercom an einer Wand in einem Winkel von 30°.
- SHS-165F ist eine Befestigung für eine versenkte Installation der Kamera TID-600R Intercom.

- ITA** ■ SBC-165W è una cover di colore bianco per il citofono TID-600R.
- SBS-165TM è un supporto per l'installazione del citofono TID-600R su una parete con un angolo di inclinazione di 30°.
- SHS-165F è un supporto per l'installazione a incasso della telecamera del citofono TID-600R.

- POR** ■ SBC-165W é uma tampa com a qual a cor da TID-600R Intercom pode ser alterada para branco.
- SBS-165TM é um suporte para instalação da TID-600R Intercom em uma parede com inclinação de 30°.
- SHS-165F é um suporte para instalação da câmera TID-600R Intercom encoberta.

- RUS** ■ SBC-165W — это покрытие, с помощью которого можно изменить цвет домофона TID-600R на белый.
- SBS-165TM — это крепление для установки домофона TID-600R на стене под углом 30°.
- SHS-165F — это крепление для установки домофонной камеры TID-600R скрытого типа.

- POL** ■ SBC-165W to pokrowiec, dzięki któremu można zmienić barwę kamery TID-600R Intercom na biały.
- SBS-165TM to uchwyt do montażu kamery TID-600R Intercom na ścianie pod kątem 30°.
- SHS-165F to uchwyt do montażu kamery TID-600R Intercom w typie podziemnym.

- TUR** ■ SBC-165W, TID-600R Intercom'un rengini beyaz olarak değiştirebilen bir dış kılıftır.
- SBS-165TM, TID-600R Intercom'u 30° eğimli bir açıyla duvara monte etme amaçlı bir montaj aparatıdır.
- SHS-165F, TID-600R Intercom kamerayı gömülü tipte monte etme amaçlı bir montaj aparatıdır.

- KOR** ■ SBC-165W는 TID-600R 인터콤의 색상을 흰색으로 변경할 수 있는 스킨 커버입니다.
- SBS-165TM은 TID-600R 인터콤을 벽면에 비스듬히(30°) 설치 시 사용하는 마운트입니다.
- SHS-165F는 TID-600R 인터콤 카메라를 매립형으로 설치할 경우 사용하는 마운트입니다.

Package (SBC-165W)

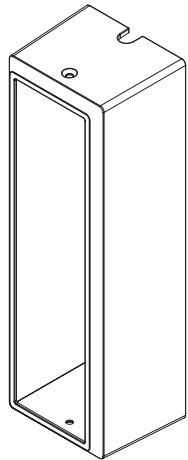

SKIN COVER

Package (SHS-165F)

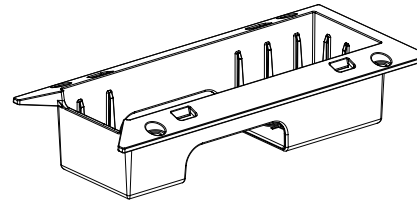

FLUSH MOUNT- BODY



SCREW 2EA

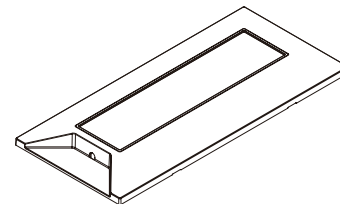

FLUSH MOUNT- COVER (White)

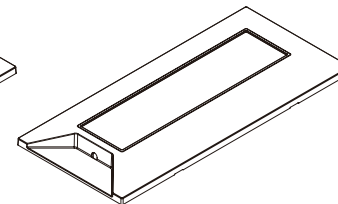

FLUSH MOUNT- COVER (Dark gray)

Installation (SBC-165W)

- 1 Install the skin cover from the Intercom's front as if covering it.

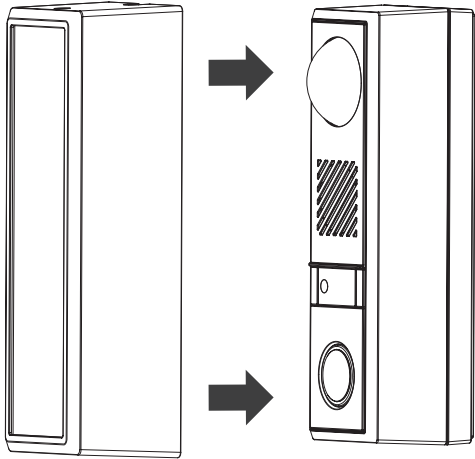

- 2 To remove the installed skin cover, take off the screw at the bottom of the Intercom and separate the Intercom's main body from the mount plate.
- 3 As shown in the figure, separate it while spreading the skin cover to both ends.

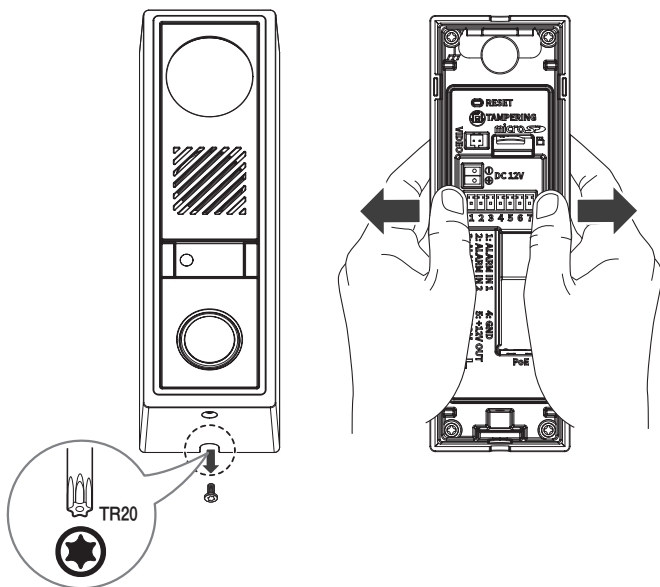

Installation (SBS-165TM)

- 1 First, attach the Intercom's mount plate to the tilt mount on the wall, then connect it to the Intercom's main body.

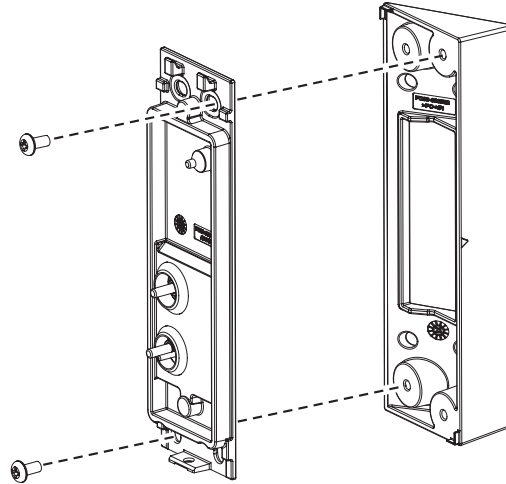

- !** Before installing the tilt mount on the wall, it is necessary to consider which direction the Intercom's front side will face. As shown in the figure below, the up and down of the tilt mount changes as per the installation direction. Check the arrow indicator of a wall on the side of the tilt mount.

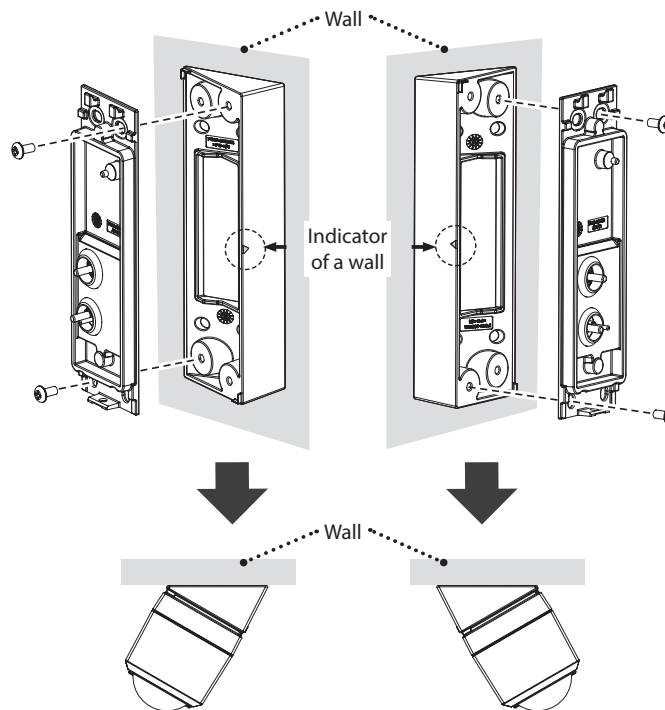

Installation (SHS-165F)

- 1 After attaching the Intercom to the flush mount, install it on the wall.
 - !** Before attaching the Intercom, confirm the up and down of the flush mount.
- 2 When the installation of flush mount on the wall is completed, attach the flush mount cover.

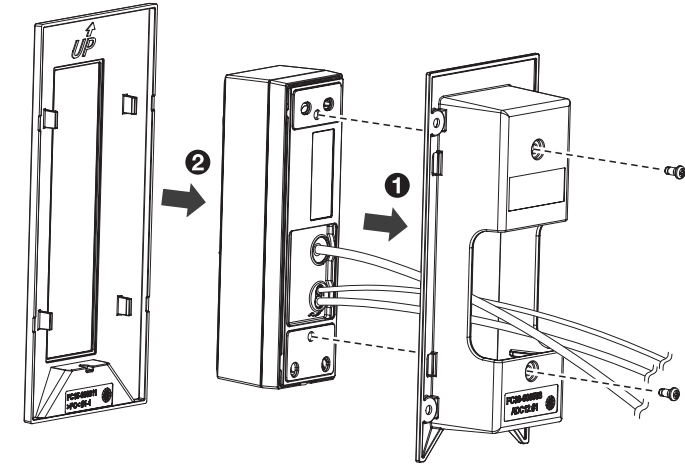

- 3 To take off the flush mount cover, separate it by pulling the area of a gap on both sides while pressing the front part as shown in the picture.

