

DH-PFA132-E

Junction Box



Features

- Aesthetic design
- Material: aluminum
- Junction box

Technical Specification

Model	DH-PFA132-E
--------------	--------------------

General

Material	Aluminum
Dimension (WxHxD)	φ156mmx39.8mm (φ6.14"x1.57")
Weight	0.48kg (1.06lb)
Load Bearing (front)	3kg (6.61lb)
Color	White
Operating Temperature	-40 °C ~+60 °C (-40 °F ~+140 °F)
Humidity	0~90% RH
Applicable Model	Please see "Accessory Selector" on www.dahuasecurity.com

Ordering Information

Type	Part Number	Description
Camera Mount Series	DH-PFA132-E	Junction box
	PFA132-E	Junction box

Dimension(mm/inch)

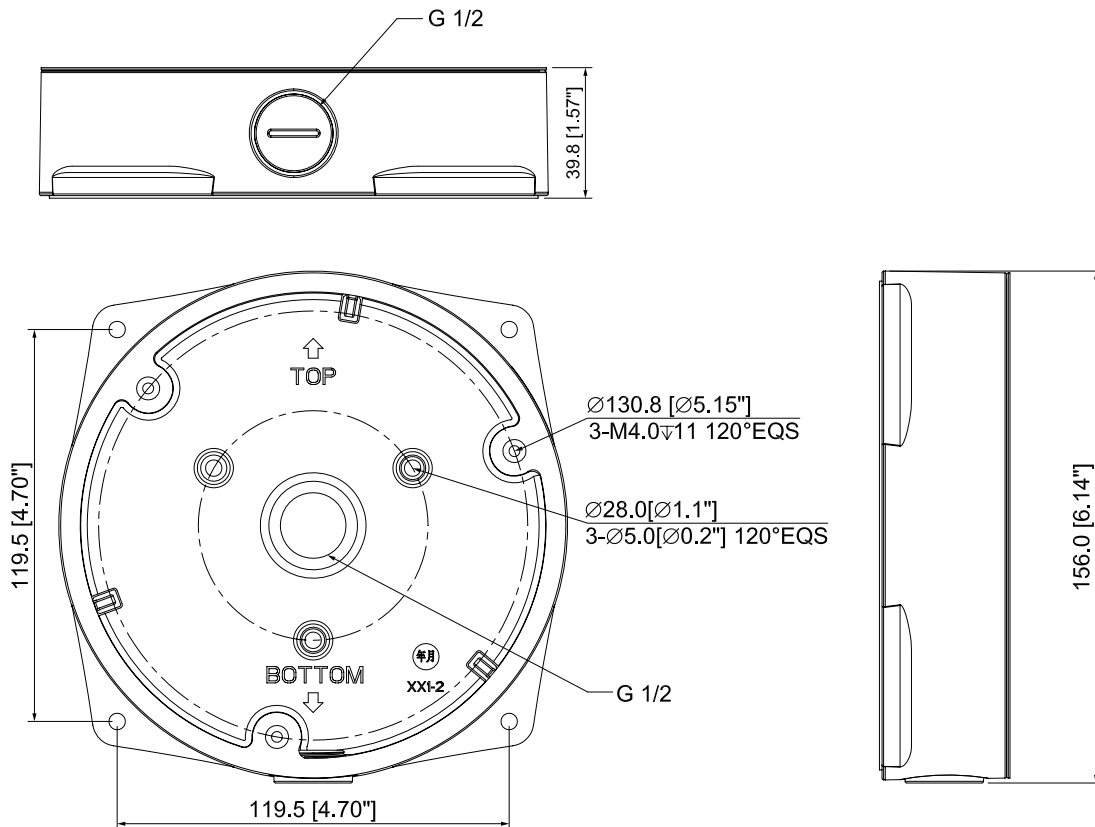

Application

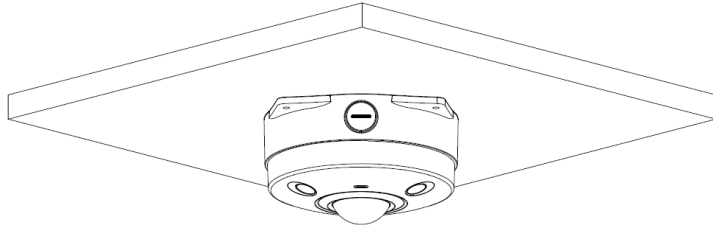

Ceiling mount

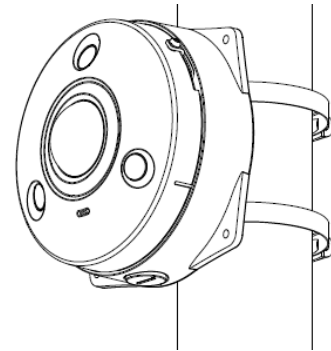

Pole mount

Package Information

- Junction box *1
- M4 screw *3
- ST4 screw *4
- Plastic anchor *4
- Water-proof joint *1
- Mounting sticker *1