



SBP-317HMW

Hanging mount



Key Features

- Can be used with PNM-9084RQZ/9085RQZ/9080VQ/PNM-9081VQ
- Mount screw size : PF 1 1/2"
- White

SBP-317HMW

Hanging mount

Specifications

Environmental

Operating Temperature / Humidity	-50°C ~ +60°C(-58°F ~ +140°F) / 0~100% RH
----------------------------------	---

Mechanical

Color	White
Material	Aluminum
RAL code	RAL9003
Product dimensions / weight	Ø322x90mm(12.68"x3.54"), 980g(2.16 lb)
Mount Screw size	PF 1 1/2"
Supported products	PNM-9084RQZ/9085RQZ ※ For further compatible models, please visit our website or use Toolbox

SBP-317HMW

Hanging mount

CAD

Unit: mm [inch]

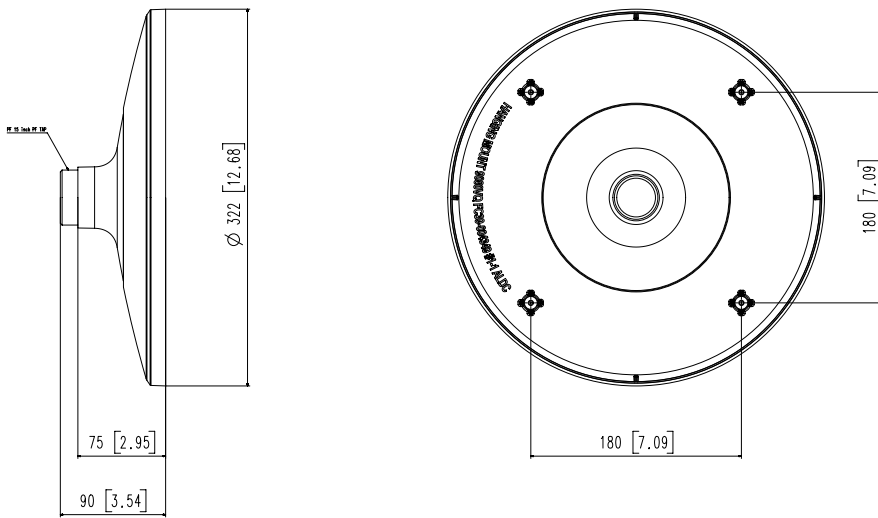

2	SBP-317HMW	19.09.18
1	SBP-317HM	17.03.17
No.	MODEL NAME	DATE

© Hanwha Techwin Co., Ltd. All rights reserved.

Unit: mm [inch] SCALE: 1/1 © Hanwha Techwin