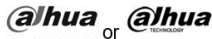

# TEST REPORT

**Application No.:** KSEM2506001506AT  
**Applicant:** ZHEJIANG DAHUA VISION TECHNOLOGY CO.,LTD.  
**Address of Applicant:** No.1399, Binxing Road, Binjiang District, Hangzhou, P.R.China  
**Manufacturer:** ZHEJIANG DAHUA VISION TECHNOLOGY CO.,LTD.  
**Address of Manufacturer:** No.1399, Binxing Road, Binjiang District, Hangzhou, P.R.China  
**Equipment Under Test (EUT):**  
**EUT Name:** IP CAMERA  
**Model No.:** Refer to page 2 ♣  
 ♣ Please refer to section 2 of this report which indicates which model was actually tested and which were electrically identical.  
**Trade Mark:**   
**Standard(s) :** EN 55032: 2015+A11:2020+A1:2020  
 EN 61000-3-3: 2013+ A1:2019+A2:2021  
 EN IEC 61000-3-2: 2019+A1:2021+A2:2024  
 EN 50130-4: 2011 +A1:2014  
 EN 55035: 2017+A11:2020  
**Date of Receipt:** 2025-06-04  
**Date of Test:** 2025-06-06 to 2025-06-06  
**Date of Issue:** 2025-06-10

<b>Test Result:</b>	<b>Pass*</b>
---------------------	--------------

\* In the configuration tested, the EUT complied with the standards specified above.

This document is issued by the Company subject to its General Conditions of Service printed overleaf, available on request or accessible at <http://www.sgs.com/en/Terms-and-Conditions> and, for electronic format documents, subject to Terms and Conditions for Electronic Documents at <http://www.sgs.com/en/Terms-and-Conditions/Terms-e-Document>. Attention is drawn to the limitation of liability, indemnification and jurisdiction issues defined therein.

Any holder of this document is advised that information contained hereon reflects the Company's findings at the time of its intervention only and within the limits of Client's instructions, if any. The Company's sole responsibility is to its Client and this document does not exonerate parties to a transaction from exercising all their rights and obligations under the transaction documents. This document cannot be reproduced except in full, without prior written approval of the Company. Any unauthorized alteration, forgery or falsification of the content or appearance of this document is unlawful and offenders may be prosecuted to the fullest extent of the law.

Unless otherwise stated the results shown in this test report refer only to the sample(s) tested and such sample(s) are retained for 30 days only.

Model No:

DH-IPC-HFW3849T1P-ZAS-PV-2712-PRO;DH-IPC-HFW3849T1-ZAS-PV-PRO;DH-IPC-HFW3849T1P-ZAS-PV-2712-PRO-ANZ;DH-IPC-HFW3849T1-ZAS-PV-PRO-ANZ;DH-IPC-HFW3649T1P-ZAS-PV-2712-PRO;DH-IPC-HFW3649T1-ZAS-PV-PRO;DH-IPC-HFW3649T1P-ZAS-PV-2712-PRO-ANZ;DH-IPC-HFW3649T1-ZAS-PV-PRO-ANZ;DH-IPC-HFW3449T1P-ZAS-PV-2712-PRO;DH-IPC-HFW3449T1-ZAS-PV-PRO;DH-IPC-HFW3449T1P-ZAS-PV-2712-PRO-ANZ;DH-IPC-HFW3449T1-ZAS-PV-PRO-ANZ;IPC-HFW3849T1P-ZAS-PV-2712-PRO;IPC-HFW3849T1-ZAS-PV-PRO;IPC-HFW3849T1P-ZAS-PV-2712-PRO-ANZ;IPC-HFW3849T1-ZAS-PV-PRO-ANZ;IPC-HFW3649T1P-ZAS-PV-2712-PRO;IPC-HFW3649T1-ZAS-PV-PRO;IPC-HFW3649T1P-ZAS-PV-2712-PRO-ANZ;IPC-HFW3649T1-ZAS-PV-PRO-ANZ;IPC-HFW3449T1P-ZAS-PV-2712-PRO;IPC-HFW3449T1-ZAS-PV-PRO;IPC-HFW3449T1P-ZAS-PV-2712-PRO-ANZ;IPC-HFW3449T1-ZAS-PV-PRO-ANZ;DH-IPC-HFW3849T1P-ZAS-PV-2712-PRO-Black;DH-IPC-HFW3849T1-ZAS-PV-PRO-Black;DH-IPC-HFW3849T1P-ZAS-PV-2712-PRO-ANZ-Black;DH-IPC-HFW3849T1-ZAS-PV-PRO-ANZ-Black;DH-IPC-HFW3649T1P-ZAS-PV-2712-PRO-Black;DH-IPC-HFW3649T1-ZAS-PV-PRO-Black;DH-IPC-HFW3649T1P-ZAS-PV-2712-PRO-ANZ-Black;DH-IPC-HFW3649T1-ZAS-PV-PRO-ANZ-Black;DH-IPC-HFW3449T1P-ZAS-PV-2712-PRO-Black;DH-IPC-HFW3449T1-ZAS-PV-PRO-Black;DH-IPC-HFW3449T1P-ZAS-PV-2712-PRO-ANZ-Black;DH-IPC-HFW3449T1-ZAS-PV-PRO-ANZ-Black;IPC-HFW3849T1P-ZAS-PV-2712-PRO-Black;IPC-HFW3849T1-ZAS-PV-PRO-Black;IPC-HFW3849T1P-ZAS-PV-2712-PRO-ANZ-Black;IPC-HFW3849T1-ZAS-PV-PRO-ANZ-Black;IPC-HFW3649T1P-ZAS-PV-2712-PRO-Black;IPC-HFW3649T1-ZAS-PV-PRO-Black;IPC-HFW3649T1P-ZAS-PV-2712-PRO-ANZ-Black;IPC-HFW3649T1-ZAS-PV-PRO-ANZ-Black;IPC-HFW3449T1P-ZAS-PV-2712-PRO-Black;IPC-HFW3449T1-ZAS-PV-PRO-Black;IPC-HFW3449T1P-ZAS-PV-2712-PRO-ANZ-Black;IPC-HFW3449T1-ZAS-PV-PRO-ANZ-Black;

<b>Revision Record</b>			
<b>Version</b>	<b>Description</b>	<b>Date</b>	<b>Remark</b>
00	Original	2025-06-10	/

<b>Authorized for issue by:</b>			
<b>Tested By</b>		<i>Kun Gu</i>	
		Kun_Gu/Project Engineer	
<b>Approved By</b>		<i>Terry Hou</i>	
		Terry Hou /Reviewer	

## 2 Test Summary

Emission Part				
Item	Standard	Method	Requirement	Result
Conducted Emissions at Mains Power Port (150kHz-30MHz)	EN 55032: 2015+A11:2020+A1:2020	EN 55032: 2015+A11:2020+A1:2020	Class B	Pass
Asymmetric Mode Conducted Emissions(150kHz-30MHz)		EN 55032: 2015+A11:2020+A1:2020	Class B	Pass
Radiated Emissions (30MHz-1GHz)		EN 55032: 2015+A11:2020+A1:2020	Class B	Pass
Radiated Emissions (Above 1GHz)		EN 55032: 2015+A11:2020+A1:2020	Class B	Pass
Voltage Fluctuations and Flicker	EN 61000-3-3: 2013+ A1:2019+A2:2021	EN 61000-3-3: 2013+ A1:2019+A2:2021	Clause 5	Pass
Harmonic Current Emission	EN IEC 61000-3-2: 2019+A1:2021+A2:2024	EN IEC 61000-3-2: 2019+A1:2021+A2:2024	Class A	Pass

Immunity Part				
Item	Standard	Method	Requirement	Result
Electrostatic Discharge	EN 50130-4: 2011 +A1:2014	EN 61000-4-2:2009	6kV Contact Discharge, 2,4,8kV Air Discharge	Pass
Radiated Immunity(80MHz-2.7GHz)		EN IEC 61000-4-3: 2020	10V/m, 80%, 1kHz sinusoidal Amp. Mod.	Pass
Electrical Fast Transients & Burst at AC Power Port		EN 61000-4-4:2012	2kV, 5/50ns Tr/Td, 100kHz Repetition Frequency	Pass
Electrical Fast Transients & Burst at Signal Port		EN 61000-4-4:2012	1kV, 5/50ns Tr/Td, 100kHz Repetition Frequency	Pass
Surge at AC Power Port		EN 61000-4-5:2014 +A1:2017	1.2/50µs Tr/Td, 0.5,1kV Line to Line, 0.5,1,2kV Line to Ground	Pass
Surge at Signal Port		EN 61000-4-5:2014 +A1:2017	1.2/50µs Tr/Td, 0.5,1kV line-to-ground	Pass
Conducted Immunity at Power Port (150kHz-100MHz)		EN 61000-4-6:2014	10Vrms (emf),80%,1kHz sinusoidal Amp. Mod.	Pass
Conducted Immunity at Signal Port (150kHz-100MHz)		EN 61000-4-6:2014	10Vrms (emf),80%,1kHz sinusoidal Amp. Mod	Pass

Immunity Part				
Item	Standard	Method	Requirement	Result
Mains Supply Voltage Variations	EN 55035: 2017+A11:2020	EN 50130-4:2011+A1:2014	Unom+10%, Unom-15%	Pass
Voltage Dips and Interruptions		EN IEC 61000-4-11:2020	80 % UT for 250per, 70 % UT for 25per, 40 % UT for 10per, 0 % UT for 250per	Pass
Electrostatic Discharge		EN 61000-4-2: 2009	±4kV Contact Discharge; ±2kV, ±4kV,±8kV Air Discharge	Pass
Radiated Immunity (80MHz-1GHz,1800MHz,2600MHz,3500MHz,5000MHz)		EN IEC 61000-4-3: 2020	3V/m, 80%, 1kHz Amp. Mod.	Pass
Electrical Fast Transients & Burst at AC Power Port		EN 61000-4-4: 2012	1kV; 5/50ns Tr/Td; 5kHz Repetition Frequency	Pass
Electrical Fast Transients & Burst at Signal Port		EN 61000-4-4: 2012	0,5kV; 5/50ns Tr/Td; 5kHz Repetition Frequency	Pass
Surge at AC Power Port		EN 61000-4-5: 2014 +A1: 2017	1,2/50µs Tr/Td; 1KV Line to Line; 2kV Line to Ground	Pass
Surge at Signal Port		EN 61000-4-5: 2014 +A1: 2017	1,2/50µs Tr/Td; 1 kV Lines to Ground, 1,2/50µs Tr/Td; 0,5 kV Shield to Ground	Pass
Conducted Immunity at AC Power Port (150kHz-80MHz)		EN 61000-4-6: 2014	0,15 to 10MHz 3Vrms (emf), 10 to 30MHz 3V to 1Vrms(emf), 30 to 80MHz 1Vrms(emf), 80%,1kHz Amp. Mod.	Pass
Conducted Immunity at Signal Port (150kHz-80MHz)		EN 61000-4-6: 2014	0,15 to 10MHz 3Vrms (emf), 10 to 30MHz 3V to 1Vrms(emf), 30 to 80MHz 1Vrms(emf), 80%,1kHz Amp. Mod.	Pass
Power Frequency Magnetic Field		EN 61000-4-8: 2010	50 or 60Hz, 1 A/m	Pass
Voltage Dips and Interruptions		EN IEC 61000-4-11:2020	<5% residual voltage for 0,5cycle, 70% residual voltage for 25cycles, <5% residual voltage for 250cycles	Pass

Model No.: DH-IPC-HFW3849T1P-ZAS-PV-2712-PRO;DH-IPC-HFW3849T1-ZAS-PV-PRO;DH-IPC-HFW3849T1P-ZAS-PV-2712-PRO-ANZ;DH-IPC-HFW3849T1-ZAS-PV-PRO-ANZ;DH-IPC-HFW3649T1P-ZAS-PV-2712-PRO;DH-IPC-HFW3649T1-ZAS-PV-PRO;DH-IPC-HFW3649T1P-ZAS-PV-2712-PRO-ANZ;DH-IPC-HFW3649T1-ZAS-PV-PRO-ANZ;DH-IPC-HFW3449T1P-ZAS-PV-2712-PRO;DH-IPC-HFW3449T1-ZAS-PV-PRO;DH-IPC-HFW3449T1P-ZAS-PV-2712-PRO-ANZ;DH-IPC-HFW3449T1-ZAS-PV-PRO-ANZ;IPC-HFW3849T1P-ZAS-PV-2712-PRO;IPC-HFW3849T1-ZAS-PV-PRO;IPC-HFW3849T1P-ZAS-PV-2712-PRO-ANZ;IPC-HFW3849T1-ZAS-PV-PRO-ANZ;IPC-HFW3649T1P-ZAS-PV-2712-PRO;IPC-HFW3649T1-ZAS-PV-PRO;IPC-HFW3649T1P-ZAS-PV-2712-PRO-ANZ;IPC-HFW3649T1-ZAS-PV-PRO-ANZ;IPC-HFW3449T1P-ZAS-PV-2712-PRO;IPC-HFW3449T1-ZAS-PV-PRO;IPC-HFW3449T1P-ZAS-PV-2712-PRO-ANZ;IPC-HFW3449T1-ZAS-PV-PRO-ANZ;DH-IPC-HFW3849T1P-ZAS-PV-2712-PRO-Black;DH-IPC-HFW3849T1-ZAS-PV-PRO-Black;DH-IPC-HFW3849T1P-ZAS-PV-2712-PRO-ANZ-Black;DH-IPC-HFW3849T1-ZAS-PV-PRO-ANZ-Black;DH-IPC-HFW3649T1P-ZAS-PV-2712-PRO-Black;DH-IPC-HFW3649T1-ZAS-PV-PRO-Black;DH-IPC-HFW3649T1P-ZAS-PV-2712-PRO-ANZ-Black;DH-IPC-HFW3649T1-ZAS-PV-PRO-ANZ-Black;DH-IPC-HFW3449T1P-ZAS-PV-2712-PRO-Black;DH-IPC-HFW3449T1-ZAS-PV-PRO-Black;DH-IPC-HFW3449T1P-ZAS-PV-2712-PRO-ANZ-Black;DH-IPC-HFW3449T1-ZAS-PV-PRO-ANZ-Black;IPC-HFW3849T1P-ZAS-PV-2712-PRO-Black;IPC-HFW3849T1-ZAS-PV-PRO-Black;IPC-HFW3849T1P-ZAS-PV-2712-PRO-ANZ-Black;IPC-HFW3849T1-ZAS-PV-PRO-ANZ-Black;IPC-HFW3649T1P-ZAS-PV-2712-PRO-Black;IPC-HFW3649T1-ZAS-PV-PRO-Black;IPC-HFW3649T1P-ZAS-PV-2712-PRO-ANZ-Black;IPC-HFW3649T1-ZAS-PV-PRO-ANZ-Black;IPC-HFW3449T1P-ZAS-PV-2712-PRO-Black;IPC-HFW3449T1-ZAS-PV-PRO-Black;IPC-HFW3449T1P-ZAS-PV-2712-PRO-ANZ-Black;IPC-HFW3449T1-ZAS-PV-PRO-ANZ-Black;

Only the model DH-IPC-HFW3849T1-ZAS-PV-PRO was tested.

There are series models mentioned in this report, and they are the similar in electrical and electronic characters. Only the model DH-IPC-HFW3849T1-ZAS-PV-PRO was tested since their differences are the model number and appearance.

### 3 Contents

	Page
<b>1 COVER PAGE .....</b>	<b>1</b>
<b>2 Test Summary .....</b>	<b>4</b>
<b>3 Contents.....</b>	<b>7</b>
<b>4 General Information .....</b>	<b>9</b>
4.1 Details of E.U.T. ....	9
4.2 Description of Support Units.....	9
4.3 Measurement Uncertainty & Decision Rule.....	9
4.4 Test Location .....	10
4.5 Test Facility .....	10
4.6 Deviation from Standards.....	10
4.7 Abnormalities from Standard Conditions.....	10
<b>5 Equipment List.....</b>	<b>11</b>
<b>6 Emission Test Results.....</b>	<b>20</b>
6.1 Conducted Emissions at Mains Power Port (150kHz-30MHz).....	20
6.2 Asymmetric Mode Conducted Emissions(150kHz-30MHz).....	25
6.3 Radiated Emissions (30MHz-1GHz).....	28
6.4 Radiated Emissions (Above 1GHz).....	34
6.5 Voltage Fluctuations and Flicker .....	40
6.6 Harmonic Current Emission.....	42
<b>7 Immunity Test Results.....</b>	<b>47</b>
7.1 Electrostatic Discharge.....	48
7.2 Radiated Immunity(80MHz-2.7GHz) .....	50
7.3 Electrical Fast Transients & Burst at AC Power Port.....	51
7.4 Electrical Fast Transients & Burst at Signal Port.....	52
7.5 Surge at AC Power Port .....	53
7.6 Surge at Signal Port .....	55
7.7 Conducted Immunity at Power Port (150kHz-100MHz).....	56
7.8 Conducted Immunity at Signal Port (150kHz-100MHz).....	57
7.9 Mains Supply Voltage Variations.....	58
7.10 Voltage Dips and Interruptions .....	59
7.11 Electrostatic Discharge.....	61
7.12 Radiated Immunity (80MHz-1GHz,1800MHz,2600MHz,3500MHz,5000MHz).....	63
7.13 Electrical Fast Transients & Burst at AC Power Port.....	65
7.14 Electrical Fast Transients & Burst at Signal Port.....	66
7.15 Surge at AC Power Port .....	67
7.16 Surge at Signal Port .....	69
7.17 Conducted Immunity at AC Power Port (150kHz-80MHz).....	70
7.18 Conducted Immunity at Signal Port (150kHz-80MHz).....	71
7.19 Power Frequency Magnetic Field .....	72
7.20 Voltage Dips and Interruptions .....	73
<b>8 Test Setup Photo.....</b>	<b>75</b>



Report No.: KSEM250600150601

Page: 8 of 105

**9 EUT Constructional Details (EUT Photos).....100**

## 4 General Information

### 4.1 Details of E.U.T.

Power supply:	DC12V,PoE(802.3at) Test Voltage:AC230V/50Hz
---------------	--

### 4.2 Description of Support Units

Description	Manufacturer	Model No.	Serial No.
AC Adapter	Gongjin	S18B73-120A150-0K	/
AC Adapter	HONOTO	ADS-12FG-12N 12012EPG	/
Notebook	APPLE	Macbook 13Pro	/
Notebook	LENOVO	K27	/
PoE Adapter	SUPLET	LAS60-57CN-RJ45	/

### 4.3 Measurement Uncertainty & Decision Rule

#### Measurement Uncertainty:

No.	Item	Measurement Uncertainty ( $U_{LAB}$ ) *	$U_{CISPR}$
1	Conducted Emission at mains port using AMN	2.4dB (9kHz to 150kHz)	3.8dB (9kHz to 150kHz)
		2.2dB (150kHz to 30MHz)	3.4dB (150kHz to 30MHz)
2	Conducted Emission at telecommunication port using AAN	4.0 dB (150kHz to 30MHz)	5.0dB (150kHz to 30MHz)
3	Radiated Power	3.2dB	4.5dB (30MHz to 300MHz)
4	Radiated Emission (10m)	4.1 dB	6.3dB (30MHz-1GHz)
5	Radiated Emission (3m)	4.6 dB (30MHz-1GHz)	6.3dB (30MHz-1GHz)
		5.0dB (1GHz-6GHz)	5.2dB (1GHz-6GHz)
		5.2dB (6GHz-18GHz)	5.5dB (6GHz-18GHz)
		5.3dB (18GHz-40GHz)	N/A

Note: The measurement uncertainty represents an expanded uncertainty expressed at approximately the 95% confidence level using a coverage factor of k=2.

#### Decision Rule:

- CISPR 16-4-2 for emission measurements is as below described.

Pass means the test result passed the test standard requirement, please find the detailed decision rule in the report relative section.

$U_{LAB}$  less than  $U_{CISPR}$ , therefore:

- compliance is deemed to occur if no measured disturbance level exceeds the disturbance limit.
- non-compliance is deemed to occur if any measured disturbance level exceeds the disturbance limit.
- For immunity testing no decision rule is applicable.

#### 4.4 Test Location

All tests were performed at:

Compliance Certification Services (Kunshan) Inc.

No.10 Weiye Rd, Innovation park, Eco&Tec, Development Zone, Kunshan City, Jiangsu, China.

Tel: +86 512 5735 5888 Fax: +86 512 5737 0818

No tests were sub-contracted.

Note:

1.SGS is not responsible for wrong test results due to incorrect information (e.g., max. internal working frequency, antenna gain, cable loss, etc) is provided by the applicant. (If applicable).

2.SGS is not responsible for the authenticity, integrity and the validity of the conclusion based on results of the data provided by applicant. (If applicable).

3. Sample source: sent by customer.

#### 4.5 Test Facility

The test facility is recognized, certified, or accredited by the following organizations:

- **A2LA**

Compliance Certification Services (Kunshan) Inc. is accredited by the American Association for Laboratory Accreditation (A2LA). Certificate No. 2541.01.

- **FCC**

Compliance Certification Services (Kunshan) Inc. has been recognized as an accredited testing laboratory. Designation Number: CN1172.

- **ISED**

Compliance Certification Services (Kunshan) Inc. has been recognized by Innovation, Science and Economic Development Canada (ISED) as an accredited testing laboratory. Company Number: 2324E

- **VCCI**

The 3m and 10m Semi-anechoic chamber and Shielded Room of Compliance Certification Services (Kunshan) Inc. has been registered in accordance with the Regulations for Voluntary Control Measures with Registration No.: R-20134, R-11600, C-11707, T-11499, G-10216 respectively.

#### 4.6 Deviation from Standards

None

#### 4.7 Abnormalities from Standard Conditions

None

## 5 Equipment List

Conducted Emissions at Mains Power Port (150kHz-30MHz)					
Equipment	Manufacturer	Model No.	Inventory No.	Cal Date	Cal Due Date
EMI TEST RECEIVER	R&S	ESCI	KS301195	03/27/2025	03/26/2026
TWO-LINE V-NETWORK	R&S	ENV216	KS301197	04/02/2025	04/01/2026
V (V-LISN)	SCHWARZBECK	NNLK 8129	KS301091	01/15/2025	01/14/2026
Pulse LIMITER	R&S	ESH3-Z2	KUS1902E001	12/05/2024	12/04/2025
Software	Faratronic	E3 v 3A1	N/A	N/A	N/A

Asymmetric Mode Conducted Emissions(150kHz-30MHz)					
Equipment	Manufacturer	Model No.	Inventory No.	Cal Date	Cal Due Date
EMI TEST RECEIVER	R&S	ESCI	KS301101	02/19/2025	02/18/2026
TWO-LINE V-NETWORK	R&S	ENV216	KS301197	04/02/2025	04/01/2026
V (V-LISN)	SCHWARZBECK	NNLK 8129	KS301091	01/15/2025	01/14/2026
Pulse LIMITER	R&S	ESH3-Z2	KUS1902E001	12/05/2024	12/04/2025
CISPR22 FOUR BALANCED TELECOM PARIS ISN	FCC	FCC-TLISN-T2-02	KS301144	04/03/2025	04/02/2026
COUPLING AND DECOUPLING NETWORK	TESEQ	ISN ST08	KS301171	12/05/2024	12/04/2025
IMPEDANCE STABILIZATION NETWORK	TESEQ	ISN T800	KS301185	09/30/2024	09/29/2025
IMPEDANCE STABILIZATION NETWORK	TESEQ	ISN T8-CAT6	KS301285	09/30/2024	09/29/2025
RF CURRENT PROBE	FCC	F-65A	CZ301012	12/05/2024	12/04/2025
Software	Faratronic	E3 v 3A1	N/A	N/A	N/A

Radiated Emissions (30MHz-1GHz)					
Equipment	Manufacturer	Model No.	Inventory No.	Cal Date	Cal Due Date
EMI Test Receiver	R&S	ESCI	KS301196	08/01/2024	07/31/2025
Antenna	TESEQ	CBL 6112D	KUS1806E006	03/23/2025	03/22/2026
Software	Faratronic	E3 v 3A1	N/A	N/A	N/A

Radiated Emissions (Above 1GHz)					
Equipment	Manufacturer	Model No.	Inventory No.	Cal Date	Cal Due Date
Spectrum Analyzer	R&S	FSU26	KS301206	03/27/2025	03/26/2026
Preamplifier	PANSHAN TECHNOLOGY	LNA:1~18G	KSEM010-2	12/06/2024	12/05/2025

Horn-antenna	SCHWARZBECK	BBHA9120D	KS301079	03/23/2025	03/22/2026
Software	Faratronic	E3 v 3A1	N/A	N/A	N/A

<b>Voltage Fluctuations and Flicker</b>					
Equipment	Manufacturer	Model No.	Inventory No.	Cal Date	Cal Due Date
Harmonic & Flicker Tester	SCHAFFNER	CCN 1000-1	KS301033	08/06/2024	08/05/2025
AC Power Source	SCHAFFNER	NSG 1007	KS301087	08/01/2024	07/31/2025
Software	TESEQ	CTS4-v 4.24.0	N/A	N/A	N/A
Harmonic/Flicker Analyzer	KIKUSUI	KHA3000	KUS2009M002-1	02/27/2025	02/26/2026
Line Impedance Network	KIKUSUI	SPEC71116	KUS2009M002-1	02/27/2025	02/26/2026
Switcher	KIKUSUI	SPEC71092	KUS2009M002-2	02/18/2025	02/17/2026
AC Power Supply(Master)	KIKUSUI	PCR24000WE 2	KUS2009M002-3	02/18/2025	02/17/2026
AC Power Supply(Slave)	KIKUSUI	PCR24000WE 2	KUS2009M002-4	02/18/2025	02/17/2026
Software	KIKUSUI	HarmoCapture 3-vv 2.5.2.00	N/A	N/A	N/A

<b>Harmonic Current Emission</b>					
Equipment	Manufacturer	Model No.	Inventory No.	Cal Date	Cal Due Date
Harmonic & Flicker Tester	SCHAFFNER	CCN 1000-1	KS301033	08/06/2024	08/05/2025
AC Power Source	SCHAFFNER	NSG 1007	KS301087	08/01/2024	07/31/2025
Software	TESEQ	CTS4-v 4.24.0	N/A	N/A	N/A
Harmonic/Flicker Analyzer	KIKUSUI	KHA3000	KUS2009M002-1	02/27/2025	02/26/2026
Line Impedance Network	KIKUSUI	SPEC71116	KUS2009M002-1	02/27/2025	02/26/2026
Switcher	KIKUSUI	SPEC71092	KUS2009M002-2	02/18/2025	02/17/2026
AC Power Supply(Master)	KIKUSUI	PCR24000WE 2	KUS2009M002-3	02/18/2025	02/17/2026
AC Power Supply(Slave)	KIKUSUI	PCR24000WE 2	KUS2009M002-4	02/18/2025	02/17/2026
Software	KIKUSUI	HarmoCapture 3-vv 2.5.2.00	N/A	N/A	N/A

<b>Electrostatic Discharge</b>					
Equipment	Manufacturer	Model No.	Inventory No.	Cal Date	Cal Due Date
ESD Simulator	EM TEST	DITO 509030	KS301147	02/06/2025	02/05/2026

<b>Radiated Immunity(80MHz-2.7GHz)</b>					
<b>Equipment</b>	<b>Manufacturer</b>	<b>Model No.</b>	<b>Inventory No.</b>	<b>Cal Date</b>	<b>Cal Due Date</b>
Synthesized Signal Generator	AGILENT	83732B	KS301183	01/15/2025	01/14/2026
Laser probe interface	AR Worldwide	FI7000	KS301193-2	N.C.R	N.C.R
E-Field Sensor	AR Worldwide	FL7006 100K-6G	KS301193-1	03/13/2025	03/12/2026
Amplifier Research (80~1000MHz 150w)	AR Worldwide	150W1000M1	KS301139	08/01/2024	07/31/2025
Amplifier Research (1~6GHz 50w)	AR Worldwide	50S1G6M1	KS301231	N.C.R	N.C.R
Dual Directional Coupler (1-11G)	AR Worldwide	C1-A47NFNF 35dB	KS301193-5	N.C.R	N.C.R
Dual Directional Coupler (80~1000MHz 400w)	AR Worldwide	DC6180	KS301193-6	N.C.R	N.C.R
RF POWER METER	BOONTON	4232A-01	KS301022	03/18/2025	03/17/2026
POWER SENSOR	BOONTON	51085	H3010235-1	03/18/2025	03/17/2026
POWER SENSOR	BOONTON	51085	H3010235-2	03/18/2025	03/17/2026
Antenna	AR Worldwide	TP1000A	CZ301029	N.C.R	N.C.R
Software	AR	emc ware-v 3.2.0.4	N/A	N/A	N/A

<b>Electrical Fast Transients &amp; Burst at AC Power Port</b>					
<b>Equipment</b>	<b>Manufacturer</b>	<b>Model No.</b>	<b>Inventory No.</b>	<b>Cal Date</b>	<b>Cal Due Date</b>
EMC Immunity Tester	EMC PARTNER	Transient2000	KS301188-1	08/01/2024	07/31/2025
Coupling Network	EMC PARTNER	CN-EFT1000	KS301188-3	08/01/2024	07/31/2025
Burst Generator	SANKI	EFT-0404S	KUS2009M002-7	08/02/2024	08/01/2025
Coupling and Decoupling Network	SANKI	CDN-4350	KUS2009M002-8	08/12/2024	08/11/2025

<b>Electrical Fast Transients &amp; Burst at Signal Port</b>					
<b>Equipment</b>	<b>Manufacturer</b>	<b>Model No.</b>	<b>Inventory No.</b>	<b>Cal Date</b>	<b>Cal Due Date</b>
EMC Immunity Tester	EMC PARTNER	Transient2000	KS301188-1	08/01/2024	07/31/2025
Coupling Network	EMC PARTNER	CN-EFT1000	KS301188-3	08/01/2024	07/31/2025
Burst Generator	SANKI	EFT-0404S	KUS2009M002-7	08/02/2024	08/01/2025
Coupling and Decoupling Network	SANKI	CDN-4350	KUS2009M002-8	08/12/2024	08/11/2025

<b>Surge at AC Power Port</b>					
<b>Equipment</b>	<b>Manufacturer</b>	<b>Model No.</b>	<b>Inventory No.</b>	<b>Cal Date</b>	<b>Cal Due Date</b>
EMC Immunity Tester	EMC PARTNER	TRA2006	KS301188-1	08/01/2024	07/31/2025
Coupling and Decoupling Network	EMC PARTNER	CDN-UTP8	KS301188-2	08/01/2024	07/31/2025
Surge Generator	SANKI	LSG-0506S	KUS2009M002-5	08/02/2024	08/01/2025
Coupling and Decoupling Network	SANKI	CDN-5350	KUS2009M002-6	08/12/2024	08/11/2025

<b>Surge at Signal Port</b>					
<b>Equipment</b>	<b>Manufacturer</b>	<b>Model No.</b>	<b>Inventory No.</b>	<b>Cal Date</b>	<b>Cal Due Date</b>
EMC Immunity Tester	EMC PARTNER	TRA2006	KS301188-1	08/01/2024	07/31/2025
Coupling and Decoupling Network	EMC PARTNER	CDN-UTP8	KS301188-2	08/01/2024	07/31/2025
Surge Generator	SANKI	LSG-0506S	KUS2009M002-5	08/02/2024	08/01/2025
Coupling and Decoupling Network	SANKI	CDN-5350	KUS2009M002-6	08/12/2024	08/11/2025

<b>Conducted Immunity at Power Port (150kHz-100MHz)</b>					
<b>Equipment</b>	<b>Manufacturer</b>	<b>Model No.</b>	<b>Inventory No.</b>	<b>Cal Date</b>	<b>Cal Due Date</b>
Test System for Conducted and Radiated Immunity	TESEQ	NSG 4070B	KSZ201705E003	12/05/2024	12/04/2025
Amplifier	TESEQ	SCCXE75	KSZ201705E004	12/05/2024	12/04/2025
EM-Koppelzange	SCHAFFNER	KEMZ 801	CZ301002	12/05/2024	12/04/2025
Attenuator	SHHX	TS2-6-1-A	CZ750027	12/16/2024	12/15/2025
Directional Coupler	HIGH POWER	C21A8	CZ750021	08/01/2024	07/31/2025
CDN (Coupling and Decoupling Network)	SCHAFFNER	CDN M216	CZ301085	02/18/2025	02/17/2026
CDN (Coupling and Decoupling Network)	SCHAFFNER	CDN M316	CZ301025	02/18/2025	02/17/2026
CDN (Coupling and Decoupling Network)	TESEQ	CDN S751	KS301184-2	02/18/2025	02/17/2026
CDN (Coupling and Decoupling Network)	TESEQ	CDN M116	KS301184-1	02/18/2025	02/17/2026
CDN	TESEQ	CDN T2-10S	KS301286	02/18/2025	02/17/2026
CDN	TESEQ	CDN T4-10S	KS301287	02/18/2025	02/17/2026

CDN	3Ctest	CDNRJ45	KS301288	08/01/2024	07/31/2025
Current Clamp	SCHAFFNER	KEMZ-801	CZ301002	12/05/2024	12/04/2025
CDN	TESEQ	CDN M432	KUS2003M001-1	01/16/2025	01/15/2026
CDN	TESEQ	CDN M432-3LN	KUS2003M001-2	01/16/2025	01/15/2026
CDN	TESEQ	CDN M232	KSZ201706E001	03/27/2025	03/26/2026
CDN	TESEQ	CDN M332	KSZ201706E002	02/18/2025	02/17/2026
Software	TESEQ	NSG 4070-v 1.3.0.1	N/A	N/A	N/A

<b>Conducted Immunity at Signal Port (150kHz-100MHz)</b>					
<b>Equipment</b>	<b>Manufacturer</b>	<b>Model No.</b>	<b>Inventory No.</b>	<b>Cal Date</b>	<b>Cal Due Date</b>
Test System for Conducted and Radiated Immunity	TESEQ	NSG 4070B	KSZ201705E003	12/05/2024	12/04/2025
Amplifier	TESEQ	SCCXE75	KSZ201705E004	12/05/2024	12/04/2025
EM-Koppelzange	SCHAFFNER	KEMZ 801	CZ301002	12/05/2024	12/04/2025
Attenuator	SHHX	TS2-6-1-A	CZ750027	12/16/2024	12/15/2025
Directional Coupler	HIGH POWER	C21A8	CZ750021	08/01/2024	07/31/2025
CDN (Coupling and Decoupling Network)	SCHAFFNER	CDN M216	CZ301085	02/18/2025	02/17/2026
CDN (Coupling and Decoupling Network)	SCHAFFNER	CDN M316	CZ301025	02/18/2025	02/17/2026
CDN (Coupling and Decoupling Network)	TESEQ	CDN S751	KS301184-2	02/18/2025	02/17/2026
CDN (Coupling and Decoupling Network)	TESEQ	CDN M116	KS301184-1	02/18/2025	02/17/2026
CDN	TESEQ	CDN T2-10S	KS301286	02/18/2025	02/17/2026
CDN	TESEQ	CDN T4-10S	KS301287	02/18/2025	02/17/2026
CDN	3Ctest	CDNRJ45	KS301288	08/01/2024	07/31/2025
Current Clamp	SCHAFFNER	KEMZ-801	CZ301002	12/05/2024	12/04/2025
CDN	TESEQ	CDN M432	KUS2003M001-1	01/16/2025	01/15/2026
CDN	TESEQ	CDN M432-3LN	KUS2003M001-2	01/16/2025	01/15/2026
CDN	TESEQ	CDN M232	KSZ201706E001	03/27/2025	03/26/2026
CDN	TESEQ	CDN M332	KSZ201706E002	02/18/2025	02/17/2026
Software	TESEQ	NSG 4070-v 1.3.0.1	N/A	N/A	N/A

<b>Mains Supply Voltage Variations</b>					
<b>Equipment</b>	<b>Manufacturer</b>	<b>Model No.</b>	<b>Inventory No.</b>	<b>Cal Date</b>	<b>Cal Due Date</b>
EMC Immunity Tester	EMC PARTNER	TRA2006	KS301188-1	08/01/2024	07/31/2025
Switcher	KIKUSUI	SPEC71092	KUS2009M002-2	02/18/2025	02/17/2026
AC Power Supply(Master)	KIKUSUI	PCR24000WE2	KUS2009M002-3	02/18/2025	02/17/2026
AC Power Supply(Slave)	KIKUSUI	PCR24000WE2	KUS2009M002-4	02/18/2025	02/17/2026
Software	KIKUSUI	Quick Immunity Sequencer 2-v 4.0.3.02	N/A	N/A	N/A

<b>Voltage Dips and Interruptions</b>					
<b>Equipment</b>	<b>Manufacturer</b>	<b>Model No.</b>	<b>Inventory No.</b>	<b>Cal Date</b>	<b>Cal Due Date</b>
EMC Immunity Tester	EMC PARTNER	TRA2006	KS301188-1	08/01/2024	07/31/2025
Switcher	KIKUSUI	SPEC71092	KUS2009M002-2	02/18/2025	02/17/2026
AC Power Supply(Master)	KIKUSUI	PCR24000WE2	KUS2009M002-3	02/18/2025	02/17/2026
AC Power Supply(Slave)	KIKUSUI	PCR24000WE2	KUS2009M002-4	02/18/2025	02/17/2026
Software	KIKUSUI	Quick Immunity Sequencer 2-v 4.0.3.02	N/A	N/A	N/A

<b>Electrostatic Discharge</b>					
<b>Equipment</b>	<b>Manufacturer</b>	<b>Model No.</b>	<b>Inventory No.</b>	<b>Cal Date</b>	<b>Cal Due Date</b>
ESD Simulator	EM TEST	DITO 509030	KS301147	02/06/2025	02/05/2026

<b>Radiated Immunity (80MHz-1GHz,1800MHz,2600MHz,3500MHz,5000MHz)</b>					
<b>Equipment</b>	<b>Manufacturer</b>	<b>Model No.</b>	<b>Inventory No.</b>	<b>Cal Date</b>	<b>Cal Due Date</b>
Synthesized Signal Generator	AGILENT	83732B	KS301183	01/15/2025	01/14/2026
Laser probe interface	AR Worldwide	FI7000	KS301193-2	N.C.R	N.C.R
E-Field Sensor	AR Worldwide	FL7006 100K-6G	KS301193-1	03/13/2025	03/12/2026
Amplifier Research (80~1000MHz 150w)	AR Worldwide	150W1000M1	KS301139	08/01/2024	07/31/2025
Amplifier Research (1~6GHz 50w)	AR Worldwide	50S1G6M1	KS301231	N.C.R	N.C.R
Dual Directional Coupler (1-11G)	AR Worldwide	C1-A47NFNF 35dB	KS301193-5	N.C.R	N.C.R
Dual Directional Coupler	AR Worldwide	DC6180	KS301193-6	N.C.R	N.C.R

(80~1000MHz 400w)					
RF POWER METER	BOONTON	4232A-01	KS301022	03/18/2025	03/17/2026
POWER SENSOR	BOONTON	51085	H3010235-1	03/18/2025	03/17/2026
POWER SENSOR	BOONTON	51085	H3010235-2	03/18/2025	03/17/2026
Antenna	AR Worldwide	TP1000A	CZ301029	N.C.R	N.C.R
Software	AR	emc ware-v 3.2.0.4	N/A	N/A	N/A

<b>Electrical Fast Transients &amp; Burst at AC Power Port</b>					
Equipment	Manufacturer	Model No.	Inventory No.	Cal Date	Cal Due Date
EMC Immunity Tester	EMC PARTNER	Transient2000	KS301188-1	08/01/2024	07/31/2025
Burst Generator	SANKI	EFT-0404S	KUS2009M002 -7	08/02/2024	08/01/2025
Coupling and Decoupling Network	SANKI	CDN-4350	KUS2009M002 -8	08/12/2024	08/11/2025

<b>Electrical Fast Transients &amp; Burst at Signal Port</b>					
Equipment	Manufacturer	Model No.	Inventory No.	Cal Date	Cal Due Date
EMC Immunity Tester	EMC PARTNER	Transient2000	KS301188-1	08/01/2024	07/31/2025
Coupling Network	EMC PARTNER	CN-EFT1000	KS301188-3	08/01/2024	07/31/2025
Burst Generator	SANKI	EFT-0404S	KUS2009M002 -7	08/02/2024	08/01/2025
Coupling and Decoupling Network	SANKI	CDN-4350	KUS2009M002 -8	08/12/2024	08/11/2025

<b>Surge at AC Power Port</b>					
Equipment	Manufacturer	Model No.	Inventory No.	Cal Date	Cal Due Date
EMC Immunity Tester	EMC PARTNER	TRA2006	KS301188-1	08/01/2024	07/31/2025
Surge Generator	SANKI	LSG-0506S	KUS2009M002 -5	08/02/2024	08/01/2025
Coupling and Decoupling Network	SANKI	CDN-5350	KUS2009M002 -6	08/12/2024	08/11/2025

<b>Surge at Signal Port</b>					
Equipment	Manufacturer	Model No.	Inventory No.	Cal Date	Cal Due Date
EMC Immunity Tester	EMC PARTNER	TRA2006	KS301188-1	08/01/2024	07/31/2025
Coupling and Decoupling Network	EMC PARTNER	CDN-UTP8	KS301188-2	08/01/2024	07/31/2025
Surge Generator	SANKI	LSG-0506S	KUS2009M002 -5	08/02/2024	08/01/2025
Coupling and	SANKI	CDN-5350	KUS2009M002	08/12/2024	08/11/2025

Decoupling Network			-6		
--------------------	--	--	----	--	--

**Conducted Immunity at AC Power Port (150kHz-80MHz)**

Equipment	Manufacturer	Model No.	Inventory No.	Cal Date	Cal Due Date
Test System for Conducted and Radiated Immunity	TESEQ	NSG 4070B	KSZ201705E003	12/05/2024	12/04/2025
Amplifier	TESEQ	SCCXE75	KSZ201705E004	12/05/2024	12/04/2025
EM-Koppelzange	SCHAFFNER	KEMZ 801	CZ301002	12/05/2024	12/04/2025
Attenuator	SHHX	TS2-6-1-A	CZ750027	12/16/2024	12/15/2025
Directional Coupler	HIGH POWER	C21A8	CZ750021	08/01/2024	07/31/2025
CDN (Coupling and Decoupling Network)	SCHAFFNER	CDN M216	CZ301085	02/18/2025	02/17/2026
CDN (Coupling and Decoupling Network)	SCHAFFNER	CDN M316	CZ301025	02/18/2025	02/17/2026
CDN (Coupling and Decoupling Network)	TESEQ	CDN M116	KS301184-1	02/18/2025	02/17/2026
CDN	TESEQ	CDN M432	KUS2003M001-1	01/16/2025	01/15/2026
CDN	TESEQ	CDN M432-3LN	KUS2003M001-2	01/16/2025	01/15/2026
CDN	TESEQ	CDN M232	KSZ201706E001	03/27/2025	03/26/2026
CDN	TESEQ	CDN M332	KSZ201706E002	02/18/2025	02/17/2026
Software	TESEQ	NSG 4070-v 1.3.0.1	N/A	N/A	N/A

**Conducted Immunity at Signal Port (150kHz-80MHz)**

Equipment	Manufacturer	Model No.	Inventory No.	Cal Date	Cal Due Date
Test System for Conducted and Radiated Immunity	TESEQ	NSG 4070B	KSZ201705E003	12/05/2024	12/04/2025
Amplifier	TESEQ	SCCXE75	KSZ201705E004	12/05/2024	12/04/2025
EM-Koppelzange	SCHAFFNER	KEMZ 801	CZ301002	12/05/2024	12/04/2025
Attenuator	SHHX	TS2-6-1-A	CZ750027	12/16/2024	12/15/2025
Directional Coupler	HIGH POWER	C21A8	CZ750021	08/01/2024	07/31/2025
CDN	TESEQ	CDN T2-10S	KS301286	02/18/2025	02/17/2026
CDN	TESEQ	CDN T4-10S	KS301287	02/18/2025	02/17/2026
CDN	3Ctest	CDNRJ45	KS301288	08/01/2024	07/31/2025
Current Clamp	SCHAFFNER	KEMZ-801	CZ301002	12/05/2024	12/04/2025
Software	TESEQ	NSG 4070-v 1.3.0.1	N/A	N/A	N/A

<b>Power Frequency Magnetic Field</b>					
<b>Equipment</b>	<b>Manufacturer</b>	<b>Model No.</b>	<b>Inventory No.</b>	<b>Cal Date</b>	<b>Cal Due Date</b>
EMC Immunity Tester	EMC PARTNER	TRA2006	KS301188-1	08/01/2024	07/31/2025
Inductive Standard Coil	EMC PARTNER	MF1000-1	KS301188-4	05/07/2024	05/06/2025

<b>Voltage Dips and Interruptions</b>					
<b>Equipment</b>	<b>Manufacturer</b>	<b>Model No.</b>	<b>Inventory No.</b>	<b>Cal Date</b>	<b>Cal Due Date</b>
EMC Immunity Tester	EMC PARTNER	TRA2006	KS301188-1	08/01/2024	07/31/2025
Switcher	KIKUSUI	SPEC71092	KUS2009M002-2	02/18/2025	02/17/2026
AC Power Supply(Master)	KIKUSUI	PCR24000WE2	KUS2009M002-3	02/18/2025	02/17/2026
AC Power Supply(Slave)	KIKUSUI	PCR24000WE2	KUS2009M002-4	02/18/2025	02/17/2026
Software	KIKUSUI	Quick Immunity Sequencer 2-v 4.0.3.02	N/A	N/A	N/A

<b>General used equipment</b>					
<b>Equipment</b>	<b>Manufacturer</b>	<b>Model No.</b>	<b>Inventory No.</b>	<b>Cal Date</b>	<b>Cal Due Date</b>
Digital Pressure Meter	Mengde	DYM3	CZ750023	01/14/2025	01/13/2026
Temperature & Humidity Recorder	JDRK	RS-WS-N01-6J	KSEM024-1 KSEM024-2 KSEM024-3 KSEM024-6 KSEM024-7 KSEM024--8 KSEM024--9	03/18/2025	03/17/2026

## 6 Emission Test Results

### 6.1 Conducted Emissions at Mains Power Port (150kHz-30MHz)

Test Requirement: EN 55032: 2015+A11:2020+A1:2020

Test Method: EN 55032: 2015+A11:2020+A1:2020

Limit:

0.15MHz-0.5MHz 66dB(μV)-56dB(μV) quasi-peak, 56dB(μV)-46dB(μV) average

0.5MHz-5MHz 56dB(μV) quasi-peak, 46dB(μV) average

5MHz-30MHz 60dB(μV) quasi-peak, 50dB(μV) average

Detector: Peak for pre-scan (9kHz resolution bandwidth) 0.15M to 30MHz

#### 6.1.1 E.U.T. Operation

Operating Environment:

Temperature: 24.5 °C

Humidity: 51.2 % RH

Atmospheric Pressure: 1010 mbar

#### 6.1.2 Test Mode Description

Pre-scan / Final test	Mode Code	Description
Final test	00	Keep EUT working normally with DC12V Adapter.
Final test	01	Keep EUT working normally with PoE Adapter.

#### 6.1.3 Test Setup Diagram

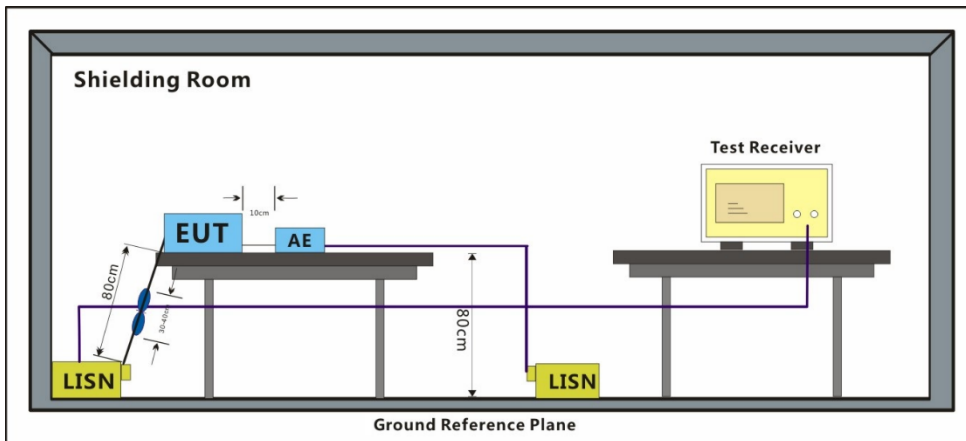

#### 6.1.4 Measurement Procedure and Data

An initial pre-scan was performed with peak detector. Quasi-Peak or Average measurement were performed at the frequencies with maximized peak emission were detected.

Remark: Level= Read Level+ Cable Loss+ LISN Factor

Test Mode: 00; Line: Live line

**Test Data :**

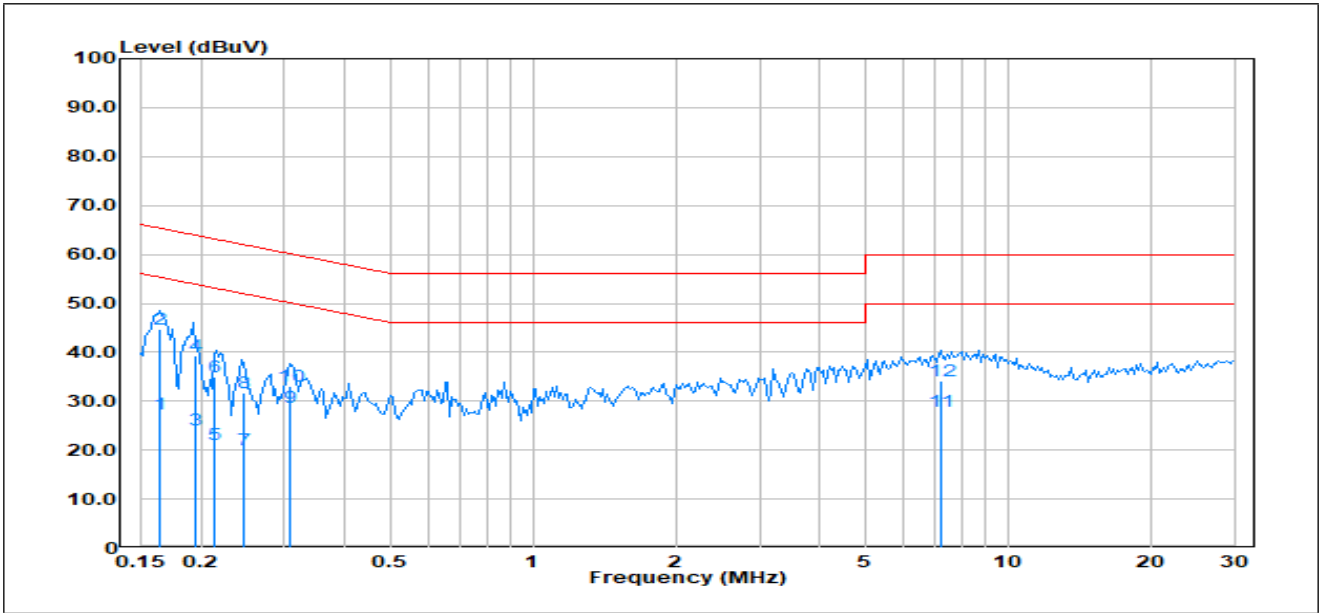

No.	Frequency (MHz)	Reading (dBuV)	Correct Factor(dB)	Result (dBuV)	Limit (dBuV)	Margin (dB)	Remark
1	0.1639	7.20	20.22	27.42	55.26	-27.84	Average
2	0.1639	24.50	20.22	44.72	65.26	-20.54	QP
3	0.1952	4.07	20.14	24.21	53.81	-29.60	Average
4	0.1952	19.16	20.14	39.30	63.81	-24.51	QP
5	0.2144	1.14	20.09	21.23	53.03	-31.80	Average
6	0.2144	14.88	20.09	34.97	63.03	-28.06	QP
7	0.2465	0.05	20.02	20.07	51.87	-31.80	Average
8	0.2465	11.67	20.02	31.69	61.87	-30.18	QP
9	0.3086	8.87	19.94	28.81	50.01	-21.20	Average
10	0.3086	13.22	19.94	33.16	60.01	-26.85	QP
11	7.2120	5.26	22.61	27.87	50.00	-22.13	Average
12	7.2120	11.64	22.61	34.25	60.00	-25.75	QP

Test Mode: 00; Line: Neutral Line

**Test Data :**

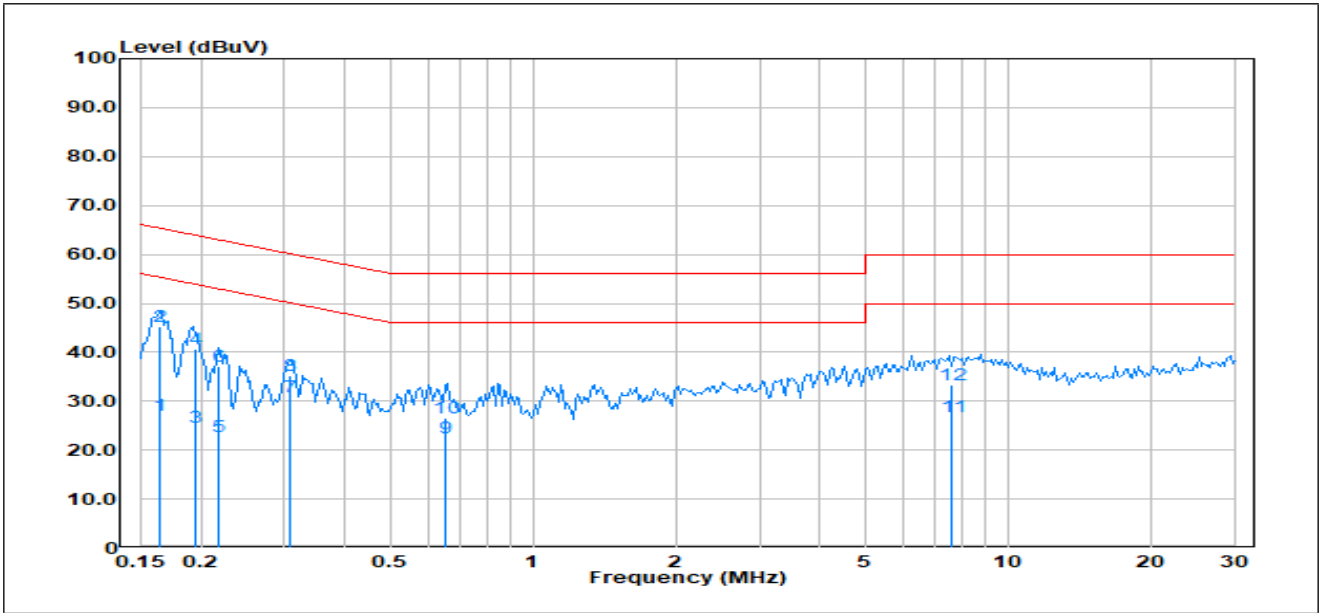

No.	Frequency (MHz)	Reading (dBuV)	Correct Factor(dB)	Result (dBuV)	Limit (dBuV)	Margin (dB)	Remark
1	0.1643	6.87	20.20	27.07	55.24	-28.17	Average
2	0.1643	24.95	20.20	45.15	65.24	-20.09	QP
3	0.1944	4.44	20.19	24.63	53.85	-29.22	Average
4	0.1944	20.34	20.19	40.53	63.85	-23.32	QP
5	0.2171	2.68	20.17	22.85	52.93	-30.08	Average
6	0.2171	16.86	20.17	37.03	62.93	-25.90	QP
7	0.3087	10.72	20.13	30.85	50.01	-19.16	Average
8	0.3087	15.07	20.13	35.20	60.01	-24.81	QP
9	0.6557	2.35	20.02	22.37	46.00	-23.63	Average
10	0.6557	6.61	20.02	26.63	56.00	-29.37	QP
11	7.6410	3.99	22.89	26.88	50.00	-23.12	Average
12	7.6410	10.52	22.89	33.41	60.00	-26.59	QP

Test Mode: 01; Line: Live line

**Test Data :**

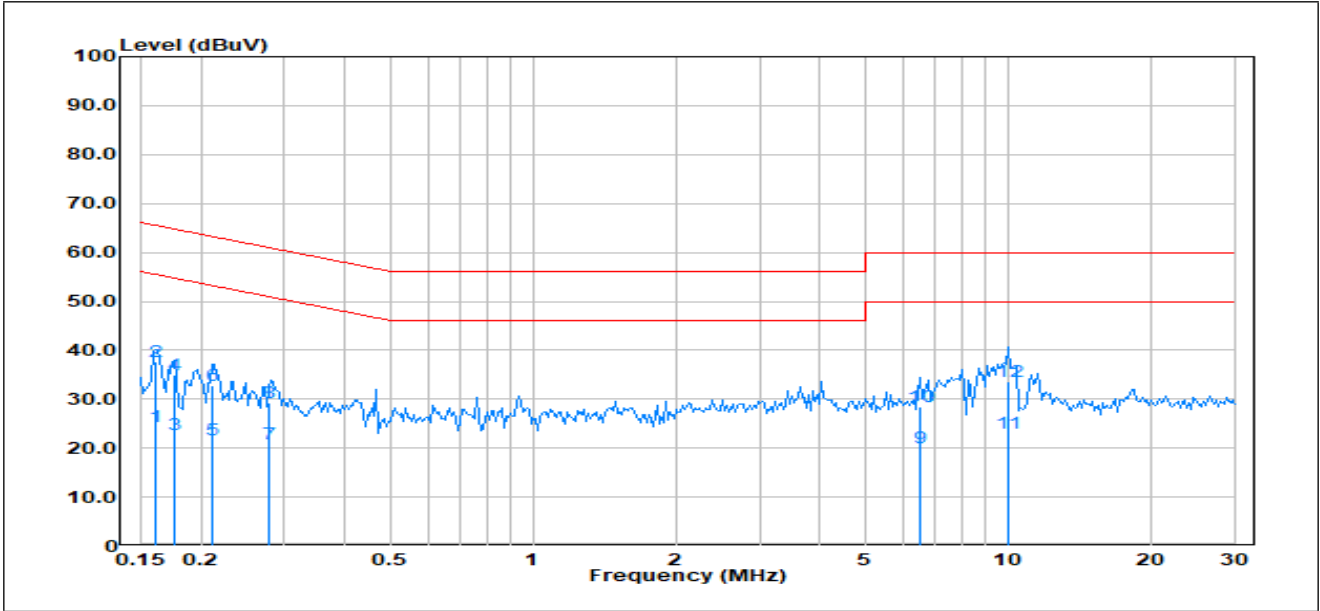

No.	Frequency (MHz)	Reading (dBuV)	Correct Factor(dB)	Result (dBuV)	Limit (dBuV)	Margin (dB)	Remark
1	0.1608	4.60	19.76	24.36	55.42	-31.06	Average
2	0.1608	17.93	19.76	37.69	65.42	-27.73	QP
3	0.1753	3.02	19.70	22.72	54.71	-31.99	Average
4	0.1753	15.33	19.70	35.03	64.71	-29.68	QP
5	0.2116	2.18	19.63	21.81	53.14	-31.33	Average
6	0.2116	13.07	19.63	32.70	63.14	-30.44	QP
7	0.2783	1.08	19.70	20.78	50.87	-30.09	Average
8	0.2783	9.63	19.70	29.33	60.87	-31.54	QP
9	6.5410	0.41	19.71	20.12	50.00	-29.88	Average
10	6.5410	8.84	19.71	28.55	60.00	-31.45	QP
11	9.9990	3.50	19.67	23.17	50.00	-26.83	Average
12	9.9990	13.98	19.67	33.65	60.00	-26.35	QP

Test Mode: 01; Line: Neutral Line

**Test Data :**

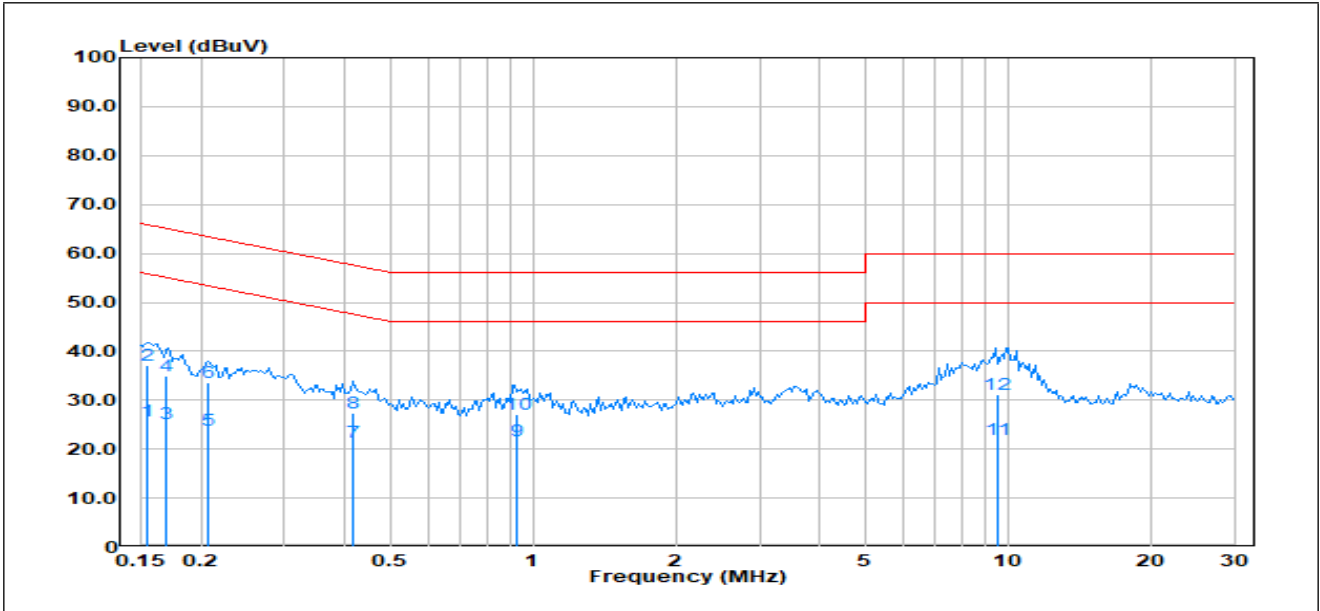

No.	Frequency (MHz)	Reading (dBuV)	Correct Factor(dB)	Result (dBuV)	Limit (dBuV)	Margin (dB)	Remark
1	0.1544	6.09	19.74	25.83	55.76	-29.93	Average
2	0.1544	17.43	19.74	37.17	65.76	-28.59	QP
3	0.1695	5.61	19.72	25.33	54.99	-29.66	Average
4	0.1695	15.37	19.72	35.09	64.99	-29.90	QP
5	0.2065	4.07	19.68	23.75	53.34	-29.59	Average
6	0.2065	13.80	19.68	33.48	63.34	-29.86	QP
7	0.4195	1.75	19.54	21.29	47.46	-26.17	Average
8	0.4195	7.92	19.54	27.46	57.46	-30.00	QP
9	0.9257	2.07	19.49	21.56	46.00	-24.44	Average
10	0.9257	7.54	19.49	27.03	56.00	-28.97	QP
11	9.4850	2.33	19.71	22.04	50.00	-27.96	Average
12	9.4850	11.57	19.71	31.28	60.00	-28.72	QP

## 6.2 Asymmetric Mode Conducted Emissions(150kHz-30MHz)

Test Requirement: EN 55032: 2015+A11:2020+A1:2020  
 Test Method: EN 55032: 2015+A11:2020+A1:2020

Limit:  
 0.15 MHz -0.5MHz 84dB(μV)-74dB(μV) quasi-peak, 74dB(μV)-64dB(μV) average  
 0.5 MHz -30MHz 74dB(μV) quasi-peak, 64dB(μV) average  
 Detector: Peak for pre-scan (9kHz resolution bandwidth) 0.15M to 30MHz

### 6.2.1 E.U.T. Operation

Operating Environment:  
 Temperature: 24.5 °C Humidity: 51.2 % RH Atmospheric Pressure: 1010 mbar

### 6.2.2 Test Mode Description

Pre-scan / Final test	Mode Code	Description
Final test	00	Keep EUT working normally with DC12V Adapter.
Final test	01	Keep EUT working normally with PoE Adapter.

### 6.2.3 Test Setup Diagram

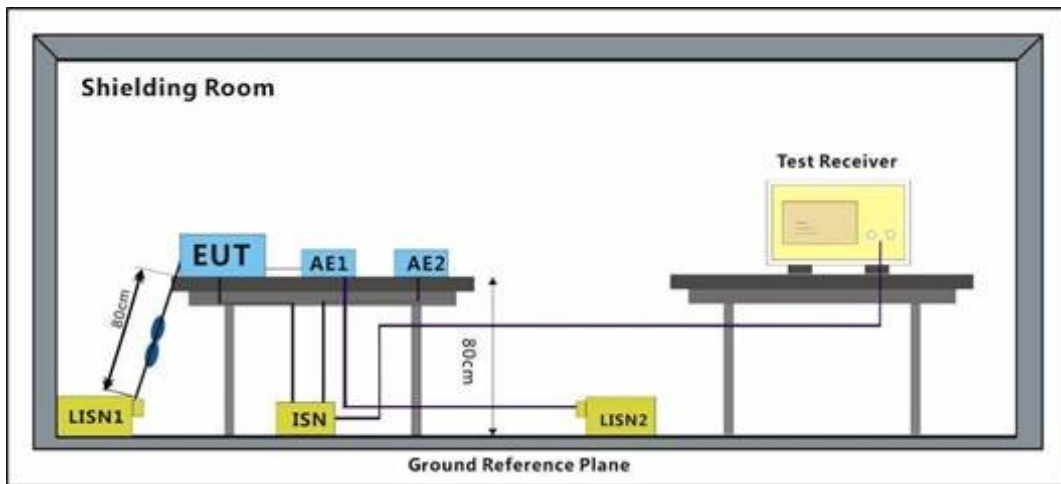

### 6.2.4 Measurement Procedure and Data

An initial pre-scan was performed with peak detector. Quasi-Peak or Average measurement were performed at the frequencies with maximized peak emission were detected.

Remark: Level= Read Level+ Cable Loss+ LISN Factor

00

**Test Data :**

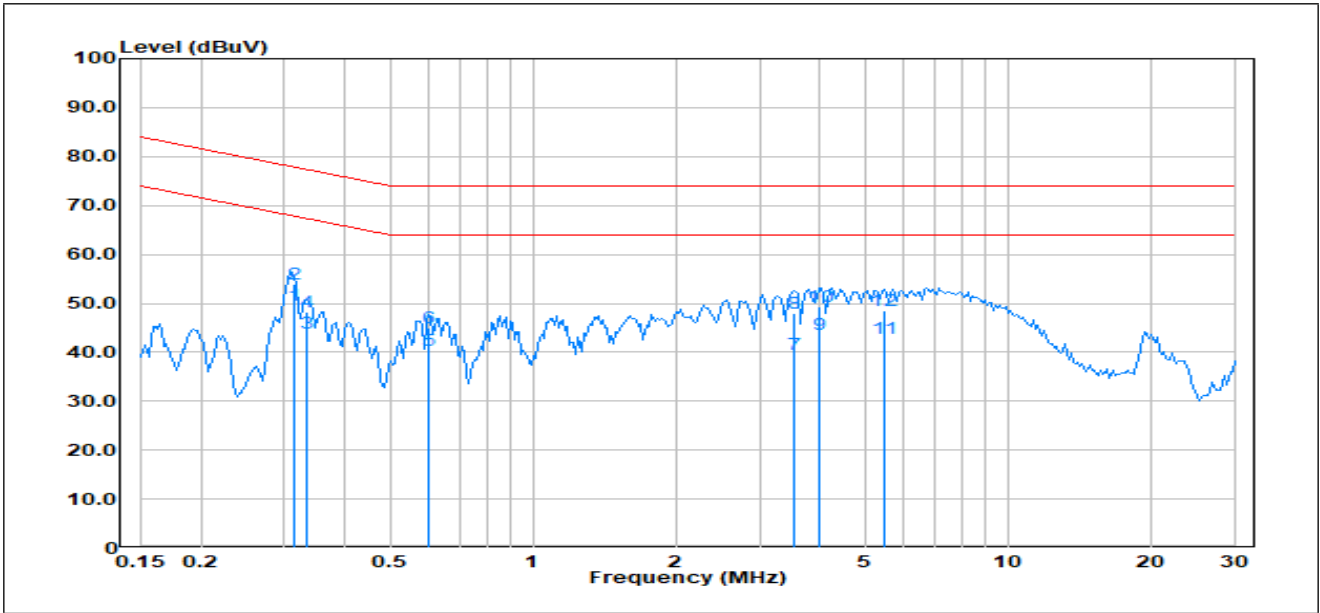

No.	Frequency (MHz)	Reading (dBuV)	Correct Factor(dB)	Result (dBuV)	Limit (dBuV)	Margin (dB)	Remark
1	0.3128	29.58	20.07	49.65	67.90	-18.25	Average
2	0.3128	33.98	20.07	54.05	77.90	-23.85	QP
3	0.3338	23.88	20.01	43.89	67.36	-23.47	Average
4	0.3338	28.31	20.01	48.32	77.36	-29.04	QP
5	0.6047	20.79	19.64	40.43	64.00	-23.57	Average
6	0.6047	25.48	19.64	45.12	74.00	-28.88	QP
7	3.5600	19.54	19.95	39.49	64.00	-24.51	Average
8	3.5600	28.10	19.95	48.05	74.00	-25.95	QP
9	4.0120	23.66	19.96	43.62	64.00	-20.38	Average
10	4.0120	29.32	19.96	49.28	74.00	-24.72	QP
11	5.4720	22.69	20.02	42.71	64.00	-21.29	Average
12	5.4720	28.58	20.02	48.60	74.00	-25.40	QP

01

**Test Data :**

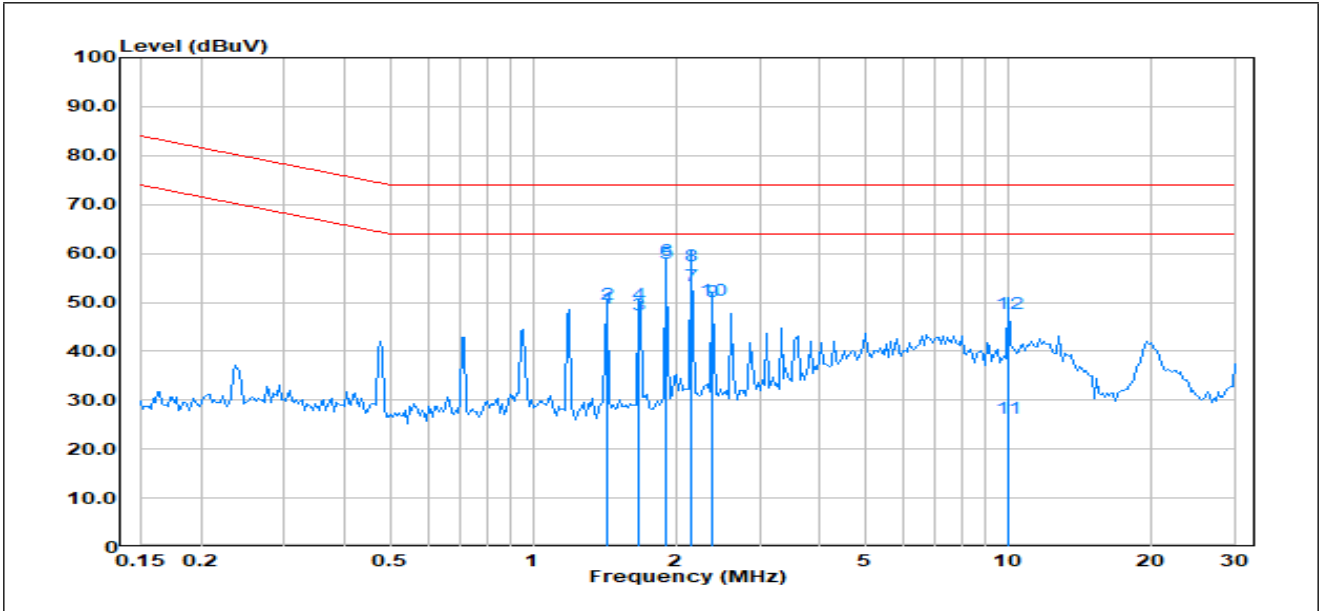

No.	Frequency (MHz)	Reading (dBuV)	Correct Factor(dB)	Result (dBuV)	Limit (dBuV)	Margin (dB)	Remark
1	1.4320	29.11	19.78	48.89	64.00	-15.11	Average
2	1.4320	29.84	19.78	49.62	74.00	-24.38	QP
3	1.6700	27.65	19.83	47.48	64.00	-16.52	Average
4	1.6700	29.69	19.83	49.52	74.00	-24.48	QP
5	1.9090	38.22	19.87	58.09	64.00	-5.91	Average
6	1.9090	38.65	19.87	58.52	74.00	-15.48	QP
7	2.1470	33.43	19.89	53.32	64.00	-10.68	Average
8	2.1470	37.64	19.89	57.53	74.00	-16.47	QP
9	2.3880	30.13	19.90	50.03	64.00	-13.97	Average
10	2.3880	30.60	19.90	50.50	74.00	-23.50	QP
11	10.0000	5.90	20.26	26.16	64.00	-37.84	Average
12	10.0000	27.42	20.26	47.68	74.00	-26.32	QP

### 6.3 Radiated Emissions (30MHz-1GHz)

Test Requirement: EN 55032: 2015+A11:2020+A1:2020  
 Test Method: EN 55032: 2015+A11:2020+A1:2020

Limit:

Test Distance: 3m  
 30MHz-230MHz: 40 dB(μV/m) quasi-peak  
 230MHz-1GHz: 47 dB(μV/m) quasi-peak  
 Detector: Peak for pre-scan (120kHz resolution bandwidth) 30MHz to 1000MHz

Test Distance: 10m  
 30MHz-230MHz: 30 dB(μV/m) quasi-peak  
 230MHz-1GHz: 37 dB(μV/m) quasi-peak  
 Detector: Peak for pre-scan (120kHz resolution bandwidth) 30MHz to 1000MHz  
 Highest internal frequency (F<sub>x</sub>): F<sub>x</sub> ≤ 108MHz  
 Highest measured frequency: 1GHz

#### 6.3.1 E.U.T. Operation

Operating Environment:  
 Temperature: 25 °C Humidity: 46 % RH Atmospheric Pressure: 1010 mbar

#### 6.3.2 Test Mode Description

Pre-scan / Final test	Mode Code	Description
Final test	00	Keep EUT working normally with DC12V Adapter.
Final test	01	Keep EUT working normally with PoE Adapter.

### 6.3.3 Test Setup Diagram

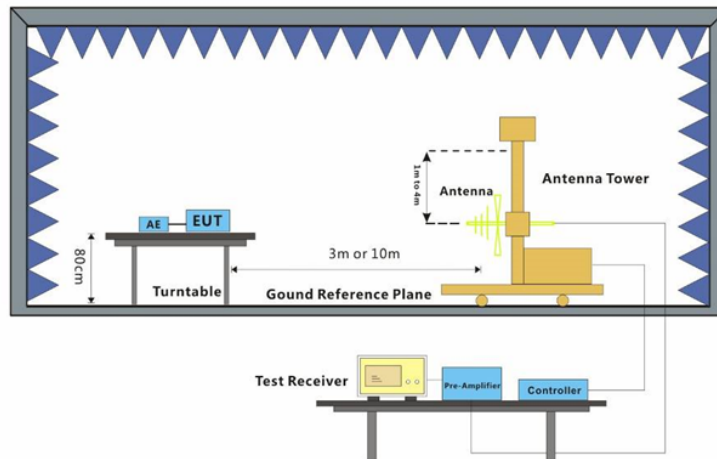

### 6.3.4 Measurement Procedure and Data

Frequency range: 30MHz-1GHz

An initial pre-scan was performed in the chamber using the spectrum analyser in peak detection mode. Quasi-peak measurements were conducted based on the peak sweep graph. The EUT was measured by BiConiLog antenna with 2 orthogonal polarities.

The red line show in graphic is the limit in standard used in this section.

Level=Read Level + Antenna Factor + Cable Loss - Preamp Factor

Test Mode: 00; Polarity: Horizontal

**Test Data :**

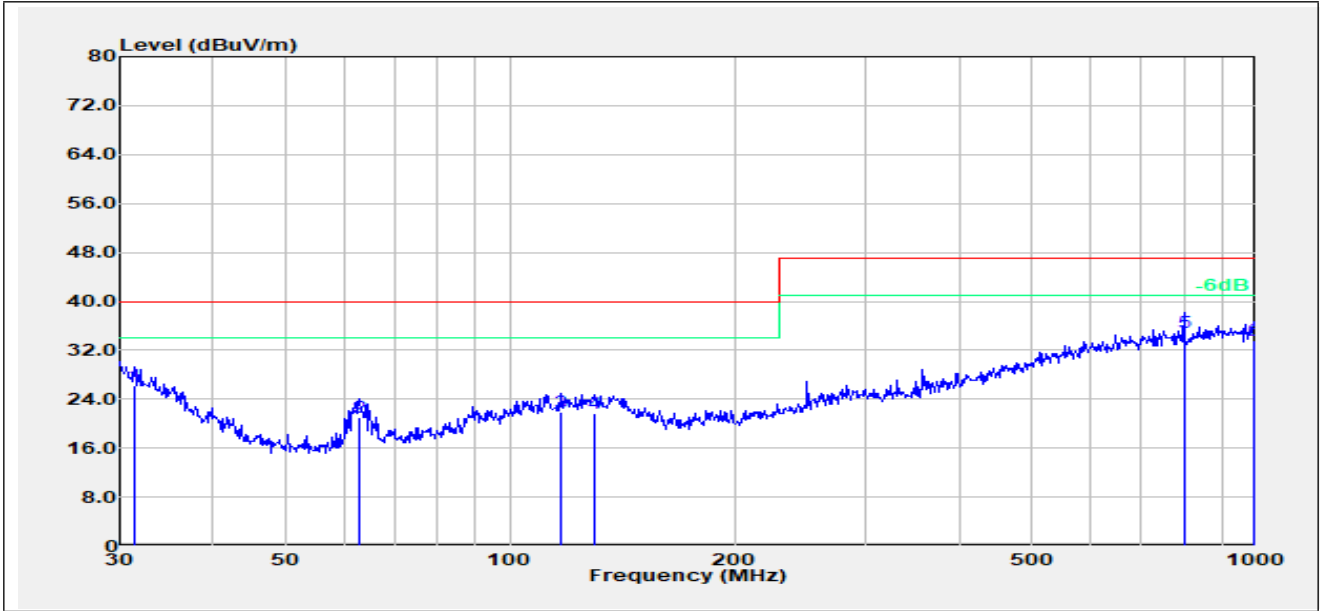

No.	Frequency (MHz)	Reading (dBuV)	Correct Factor(dB/m)	Result (dBuV/m)	Limit (dBuV/m)	Margin (dB)	Height (cm)	Degree (deg.)	Remark
1	31.3990	2.25	23.93	26.18	40.00	-13.82	100	294	QP
2	62.6510	9.15	11.80	20.95	40.00	-19.05	200	342	QP
3	117.3600	2.08	19.77	21.85	40.00	-18.15	200	0	QP
4	129.9230	1.25	20.34	21.59	40.00	-18.41	100	200	QP
5	801.7860	4.59	30.34	34.93	47.00	-12.07	200	51	QP
6	996.5000	2.06	31.52	33.58	47.00	-13.42	100	294	QP

Test Mode: 00; Polarity: Vertical

**Test Data :**

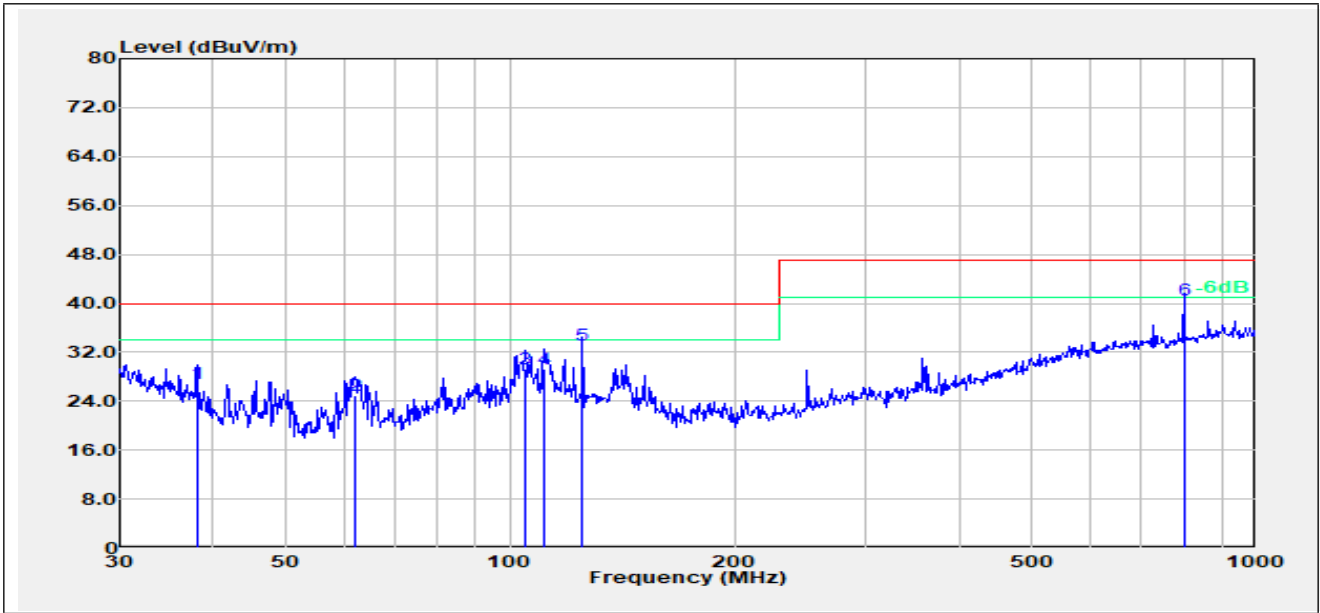

No.	Frequency (MHz)	Reading (dBUV)	Correct Factor(dB/m)	Result (dBUV/m)	Limit (dBUV/m)	Margin (dB)	Height (cm)	Degree (deg.)	Remark
1	38.0780	8.41	18.49	26.90	40.00	-13.10	100	19	QP
2	61.9951	13.08	11.87	24.95	40.00	-15.05	100	12	QP
3	104.5360	10.47	18.84	29.31	40.00	-10.69	100	8	QP
4	111.3470	9.67	19.65	29.32	40.00	-10.68	100	360	QP
5	125.0070	12.75	20.40	33.15	40.00	-6.85	100	263	QP
6	801.7860	10.23	30.34	40.57	47.00	-6.43	100	248	QP

Test Mode: 01; Polarity: Horizontal

**Test Data :**

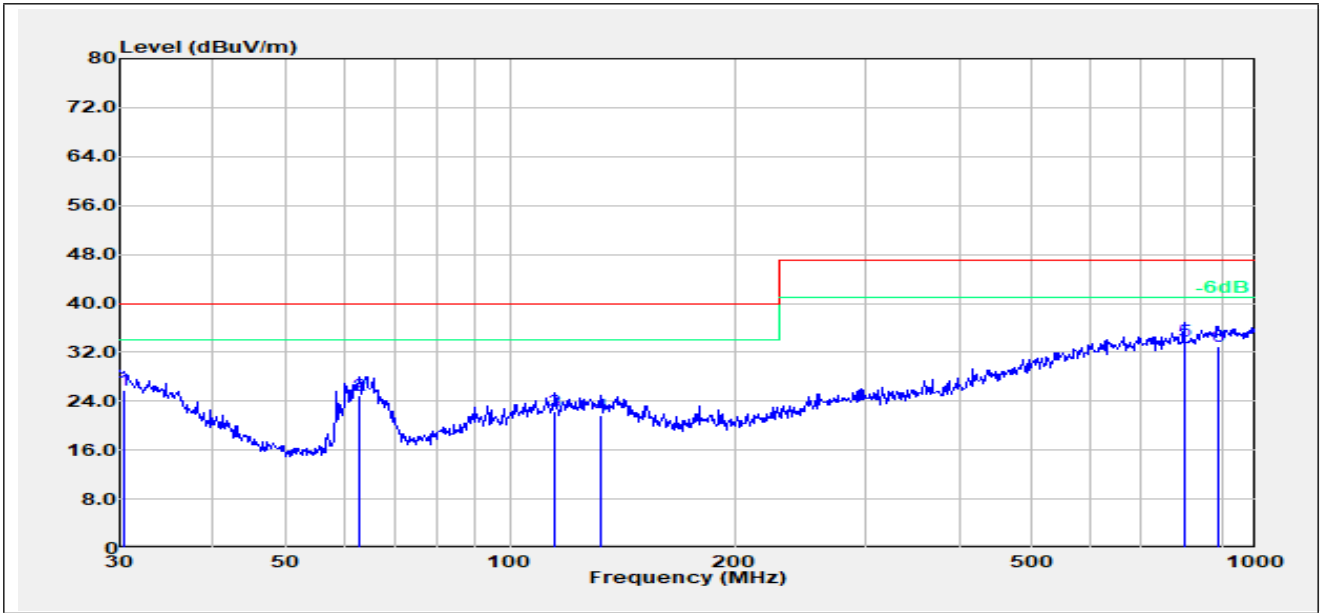

No.	Frequency (MHz)	Reading (dBuV)	Correct Factor(dB/m)	Result (dBuV/m)	Limit (dBuV/m)	Margin (dB)	Height (cm)	Degree (deg.)	Remark
1	30.3170	1.02	24.87	25.89	40.00	-14.11	100	89	QP
2	62.6510	13.04	11.80	24.84	40.00	-15.16	200	0	QP
3	114.9170	2.61	19.61	22.22	40.00	-17.78	200	204	QP
4	132.2210	1.59	20.10	21.69	40.00	-18.31	100	356	QP
5	801.7860	3.39	30.34	33.73	47.00	-13.27	200	237	QP
6	890.7280	1.68	31.35	33.03	47.00	-13.97	100	0	QP

Test Mode: 01; Polarity: Vertical

**Test Data :**

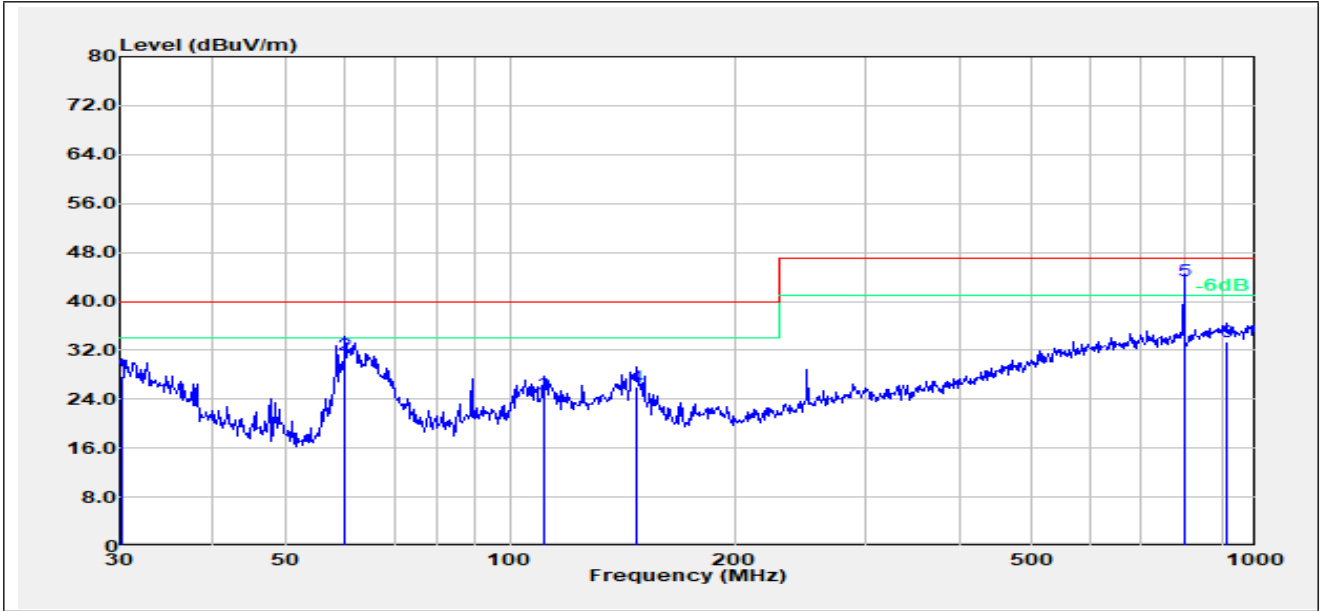

No.	Frequency (MHz)	Reading (dBuV)	Correct Factor(dB/m)	Result (dBuV/m)	Limit (dBuV/m)	Margin (dB)	Height (cm)	Degree (deg.)	Remark
1	30.2111	2.69	24.95	27.64	40.00	-12.36	100	360	QP
2	60.0691	19.25	11.88	31.13	40.00	-8.87	100	1	QP
3	111.3468	5.06	19.65	24.71	40.00	-15.29	100	336	QP
4	147.9214	8.36	17.57	25.93	40.00	-14.07	100	194	QP
5	801.7863	12.97	30.34	43.31	47.00	-3.69	100	79	QP
6	912.8621	2.05	31.44	33.49	47.00	-13.51	100	12	QP

## 6.4 Radiated Emissions (Above 1GHz)

Test Requirement: EN 55032: 2015+A11:2020+A1:2020  
 Test Method: EN 55032: 2015+A11:2020+A1:2020

Limit:  
 1000MHz-6000MHz: 74 dB( $\mu$ V/m) peak; 54 dB( $\mu$ V/m) average  
 Detector: Peak for pre-scan (1000kHz resolution bandwidth) 1000MHz to 6000MHz

Highest internal frequency ( $F_x$ ): Highest measured frequency:  
 $F_x \leq 108\text{MHz}$  1GHz  
 $108\text{MHz} < F_x \leq 500\text{MHz}$  2GHz  
 $500\text{MHz} < F_x \leq 1\text{GHz}$  5GHz  
 $F_x > 1\text{GHz}$   $5 \times F_x$  up to a maximum of 6GHz

### 6.4.1 E.U.T. Operation

Operating Environment:  
 Temperature: 25 °C Humidity: 49 % RH Atmospheric Pressure: 1010 mbar

### 6.4.2 Test Mode Description

Pre-scan / Final test	Mode Code	Description
Final test	00	Keep EUT working normally with DC12V Adapter.
Final test	01	Keep EUT working normally with PoE Adapter.

### 6.4.3 Test Setup Diagram

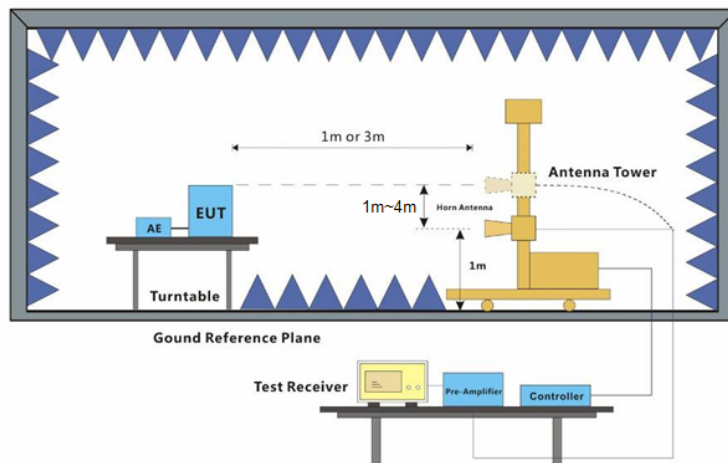

#### **6.4.4 Measurement Procedure and Data**

Frequency range: Above 1GHz

An initial pre-scan was performed in the chamber using the spectrum analyser in peak detection mode. Average measurements were conducted based on the peak sweep graph. The EUT was measured by Horn antenna with 2 orthogonal polarities.

The red line show in graphic is the limit in standard used in this section.

Level=Read Level + Antenna Factor + Cable Loss - Preamp Factor

Test Mode: 00; Polarity: Horizontal

**Test Data :**

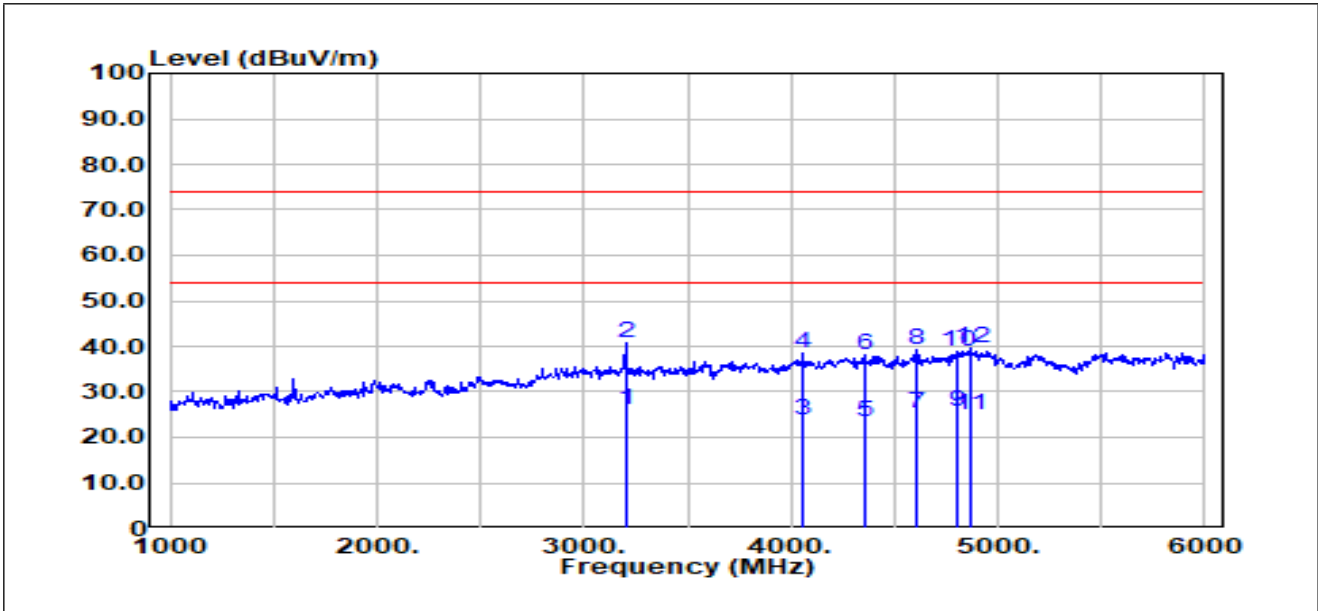

No.	Frequency (MHz)	Reading (dBUV)	Correct Factor(dB/m)	Result (dBUV/m)	Limit (dBUV/m)	Margin (dB)	Height (cm)	Degree (deg.)	Remark
1	3200.0000	43.26	-17.04	26.22	54.00	-27.78	100	359	Average
2	3200.0000	57.73	-17.04	40.69	74.00	-33.31	100	359	Peak
3	4060.0000	38.17	-14.52	23.65	54.00	-30.35	100	303	Average
4	4060.0000	52.87	-14.52	38.35	74.00	-35.65	100	303	Peak
5	4355.0000	37.66	-14.14	23.52	54.00	-30.48	100	220	Average
6	4355.0000	52.35	-14.14	38.21	74.00	-35.79	100	220	Peak
7	4605.0000	38.96	-13.51	25.45	54.00	-28.55	100	316	Average
8	4605.0000	52.74	-13.51	39.23	74.00	-34.77	100	316	Peak
9	4800.0000	38.69	-13.08	25.61	54.00	-28.39	200	0	Average
10	4800.0000	52.11	-13.08	39.03	74.00	-34.97	200	0	Peak
11	4865.0000	38.02	-13.00	25.02	54.00	-28.98	100	84	Average
12	4865.0000	52.74	-13.00	39.74	74.00	-34.26	100	84	Peak

Test Mode: 00; Polarity: Vertical

**Test Data :**

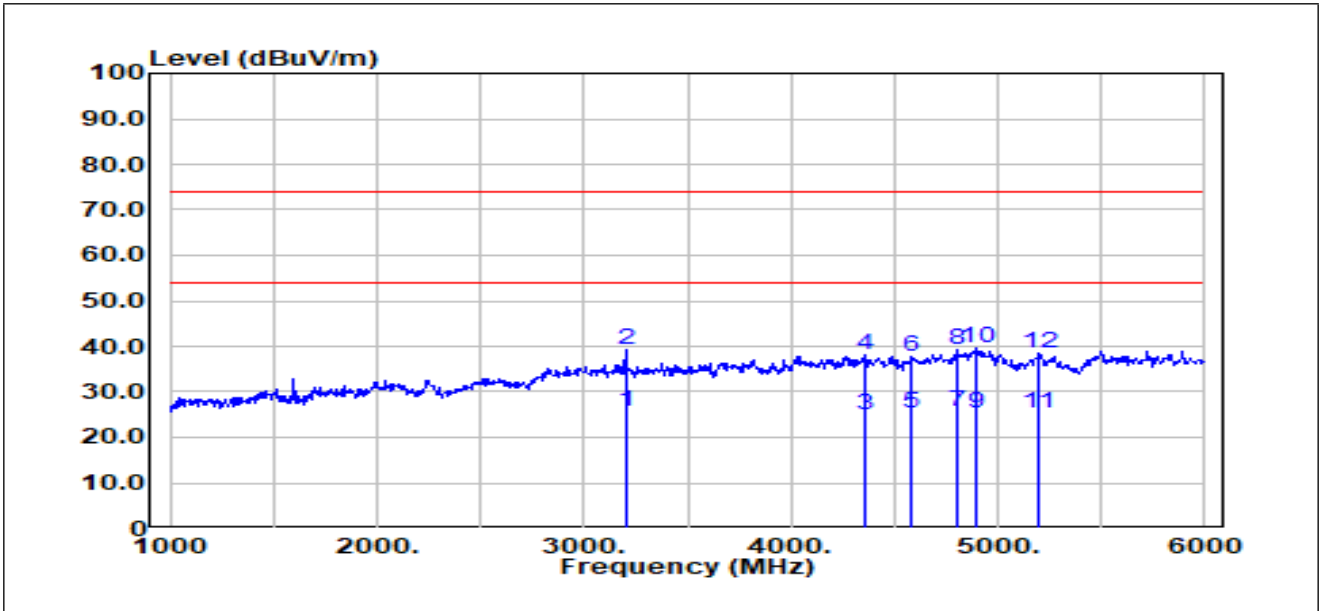

No.	Frequency (MHz)	Reading (dBuV)	Correct Factor(dB/m)	Result (dBuV/m)	Limit (dBuV/m)	Margin (dB)	Height (cm)	Degree (deg.)	Remark
1	3200.0000	42.54	-17.04	25.50	54.00	-28.50	100	29	Average
2	3200.0000	56.41	-17.04	39.37	74.00	-34.63	100	29	Peak
3	4360.0000	39.14	-14.11	25.03	54.00	-28.97	200	306	Average
4	4360.0000	52.04	-14.11	37.93	74.00	-36.07	200	306	Peak
5	4580.0000	38.92	-13.47	25.45	54.00	-28.55	100	249	Average
6	4580.0000	51.30	-13.47	37.83	74.00	-36.17	100	249	Peak
7	4800.0000	38.73	-13.08	25.65	54.00	-28.35	100	175	Average
8	4800.0000	52.45	-13.08	39.37	74.00	-34.63	100	175	Peak
9	4895.0000	38.25	-12.92	25.33	54.00	-28.67	100	223	Average
10	4895.0000	52.46	-12.92	39.54	74.00	-34.46	100	223	Peak
11	5195.0000	38.14	-12.99	25.15	54.00	-28.85	100	184	Average
12	5195.0000	51.46	-12.99	38.47	74.00	-35.53	100	184	Peak

Test Mode: 01; Polarity: Horizontal

**Test Data :**

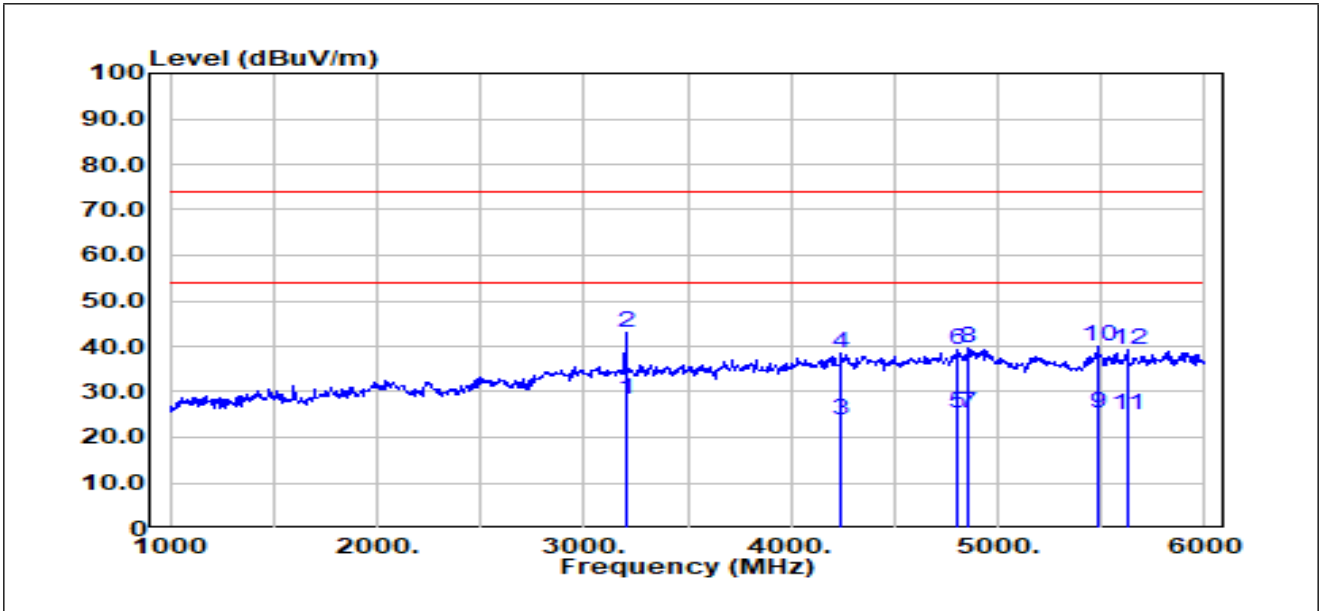

No.	Frequency (MHz)	Reading (dBuV)	Correct Factor(dB/m)	Result (dBuV/m)	Limit (dBuV/m)	Margin (dB)	Height (cm)	Degree (deg.)	Remark
1	3200.0000	45.29	-17.04	28.25	54.00	-25.75	100	355	Average
2	3200.0000	60.03	-17.04	42.99	74.00	-31.01	100	355	Peak
3	4245.0000	37.62	-13.96	23.66	54.00	-30.34	100	180	Average
4	4245.0000	52.63	-13.96	38.67	74.00	-35.33	100	180	Peak
5	4800.0000	38.40	-13.08	25.32	54.00	-28.68	100	0	Average
6	4800.0000	52.37	-13.08	39.29	74.00	-34.71	100	0	Peak
7	4860.0000	38.47	-13.02	25.45	54.00	-28.55	100	303	Average
8	4860.0000	52.77	-13.02	39.75	74.00	-34.25	100	303	Peak
9	5480.0000	38.49	-13.05	25.44	54.00	-28.56	100	258	Average
10	5480.0000	52.88	-13.05	39.83	74.00	-34.17	100	258	Peak
11	5630.0000	37.85	-12.83	25.02	54.00	-28.98	200	193	Average
12	5630.0000	52.23	-12.83	39.40	74.00	-34.60	200	193	Peak

Test Mode: 01; Polarity: Vertical

**Test Data :**

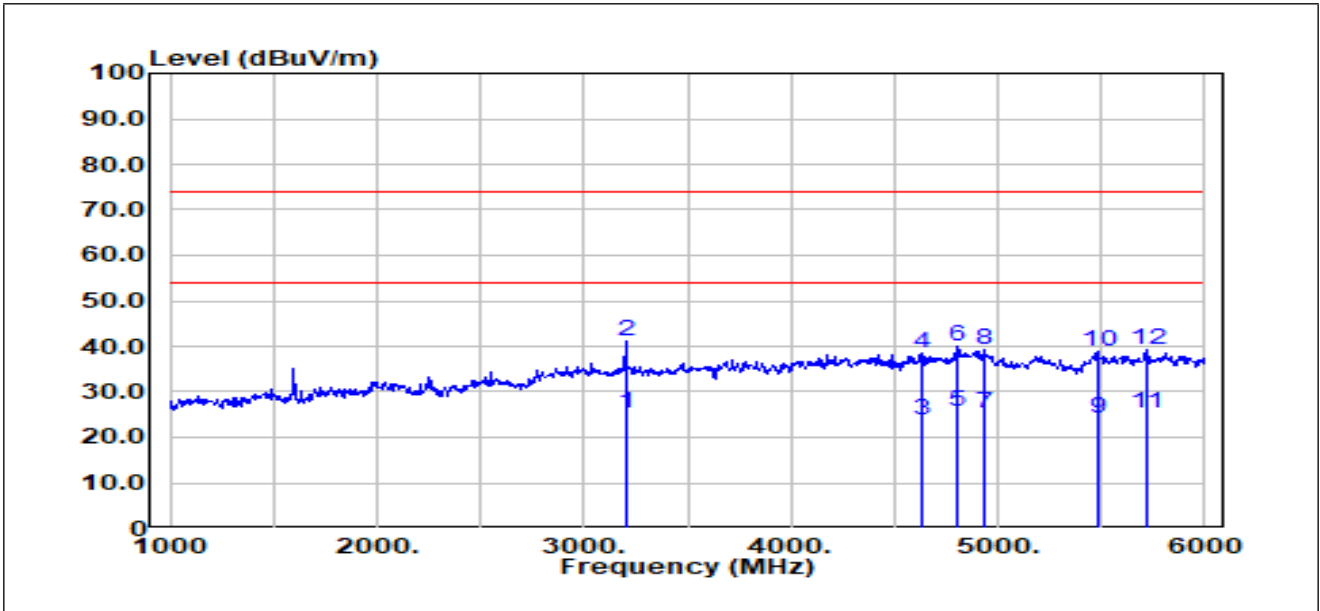

No.	Frequency (MHz)	Reading (dBuV)	Correct Factor(dB/m)	Result (dBuV/m)	Limit (dBuV/m)	Margin (dB)	Height (cm)	Degree (deg.)	Remark
1	3200.0000	42.26	-17.04	25.22	54.00	-28.78	100	29	Average
2	3200.0000	58.01	-17.04	40.97	74.00	-33.03	100	29	Peak
3	4630.0000	37.04	-13.39	23.65	54.00	-30.35	100	291	Average
4	4630.0000	51.87	-13.39	38.48	74.00	-35.52	100	291	Peak
5	4800.0000	38.73	-13.08	25.65	54.00	-28.35	100	209	Average
6	4800.0000	52.98	-13.08	39.90	74.00	-34.10	100	209	Peak
7	4935.0000	38.40	-12.95	25.45	54.00	-28.55	100	111	Average
8	4935.0000	52.30	-12.95	39.35	74.00	-34.65	100	111	Peak
9	5485.0000	37.06	-13.04	24.02	54.00	-29.98	100	246	Average
10	5485.0000	51.92	-13.04	38.88	74.00	-35.12	100	246	Peak
11	5715.0000	37.67	-12.47	25.20	54.00	-28.80	200	184	Average
12	5715.0000	51.84	-12.47	39.37	74.00	-34.63	200	184	Peak

## 6.5 Voltage Fluctuations and Flicker

Test Requirement: EN 61000-3-3: 2013+ A1:2019+A2:2021

Test Method: EN 61000-3-3: 2013+ A1:2019+A2:2021

### 6.5.1 E.U.T. Operation

Operating Environment:

Temperature: 24.5 °C

Humidity: 51.2 % RH

Atmospheric Pressure: 1010 mbar

### 6.5.2 Test Mode Description

Pre-scan / Final test	Mode Code	Description
Final test	00	Keep EUT working normally with DC12V Adapter.
Final test	01	Keep EUT working normally with PoE Adapter.

### 6.5.3 Test Setup Diagram

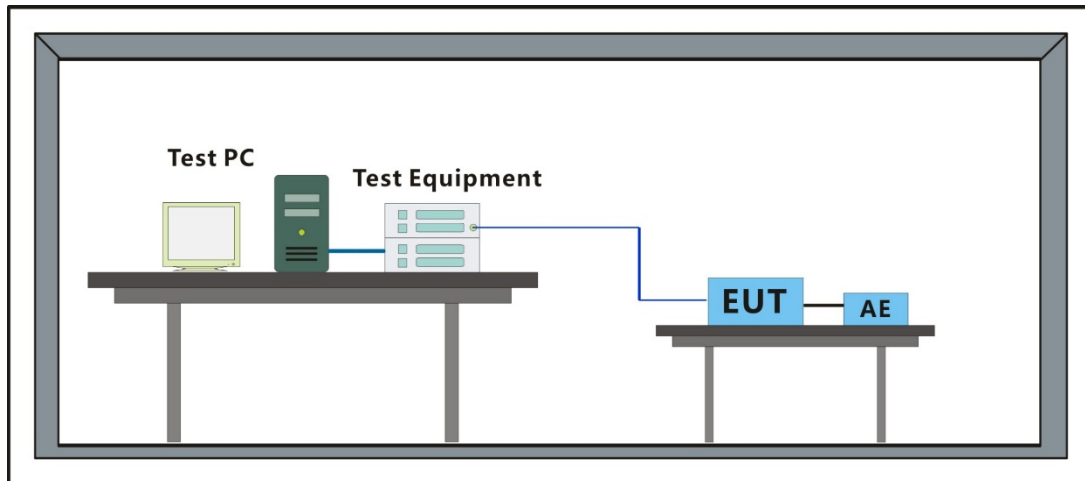

### 6.5.4 Measurement Procedure and Data

00

Parameter values recorded during the test:↵

<u>Vrms</u> at the end of test (Volt):	228.77↵				
T-max (mS):	0	Test limit (mS):	500.0	Pass↵	
Highest dc (%):	0.00	Test limit (%):	3.30	Pass↵	
Highest dmax (%):	0.00	Test limit (%):	4.00	Pass↵	
Highest Pst (10 min. period):	0.064	Test limit:	1.000	Pass	↵
Highest Plt (2 hr. period):	0.028	Test limit:	0.650	Pass↵	

01

Parameter values recorded during the test:↵

<u>Vrms</u> at the end of test (Volt):	229.13↵				
T-max (mS):	0	Test limit (mS):	500.0	Pass↵	
Highest dc (%):	0.00	Test limit (%):	3.30	Pass↵	
Highest dmax (%):	0.00	Test limit (%):	4.00	Pass↵	
Highest Pst (10 min. period):	0.062	Test limit:	1.000	Pass	↵
Highest Plt (2 hr. period):	0.028	Test limit:	0.650	Pass↵	

## 6.6 Harmonic Current Emission

Test Requirement: EN IEC 61000-3-2: 2019+A1:2021+A2:2024  
 Test Method: EN IEC 61000-3-2: 2019+A1:2021+A2:2024

### 6.6.1 E.U.T. Operation

Operating Environment:  
 Temperature: 24.5 °C      Humidity: 51.2 % RH      Atmospheric Pressure: 1010 mbar

### 6.6.2 Test Mode Description

Pre-scan / Final test	Mode Code	Description
Final test	00	Keep EUT working normally with DC12V Adapter.
Final test	01	Keep EUT working normally with PoE Adapter.

### 6.6.3 Test Setup Diagram

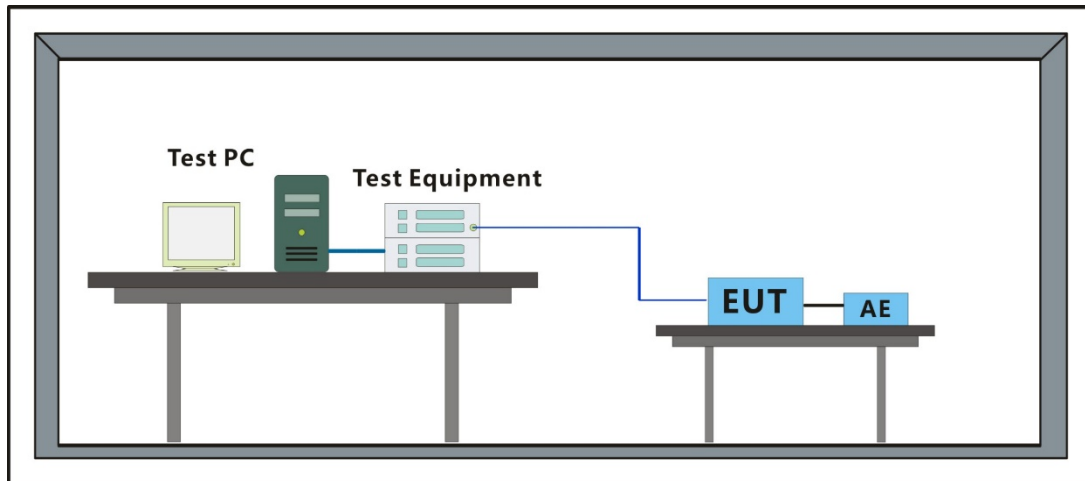

### 6.6.4 Measurement Procedure and Data

Frequency Range: 100Hz to 2kHz

Test Mode: 00

Harm#	Harmonics V-rms	Limit V-rms	% of Limit	Status
2	0.150	0.457	32.87	OK
3	0.448	2.058	21.77	OK
4	0.038	0.457	8.25	OK
5	0.037	0.915	4.09	OK
6	0.077	0.457	16.85	OK
7	0.048	0.686	7.01	OK
8	0.046	0.457	10.01	OK
9	0.023	0.457	5.13	OK
10	0.022	0.457	4.80	OK
11	0.019	0.229	8.15	OK
12	0.017	0.229	7.39	OK
13	0.017	0.229	7.29	OK
14	0.014	0.229	6.21	OK
15	0.013	0.229	5.75	OK
16	0.012	0.229	5.36	OK
17	0.015	0.229	6.61	OK
18	0.014	0.229	6.24	OK
19	0.012	0.229	5.37	OK
20	0.010	0.229	4.16	OK
21	0.012	0.229	5.42	OK
22	0.007	0.229	3.18	OK
23	0.014	0.229	6.00	OK
24	0.005	0.229	2.29	OK
25	0.011	0.229	4.87	OK
26	0.010	0.229	4.38	OK
27	0.011	0.229	4.97	OK
28	0.007	0.229	3.21	OK
29	0.008	0.229	3.31	OK
30	0.007	0.229	2.94	OK
31	0.008	0.229	3.56	OK
32	0.005	0.229	2.12	OK
33	0.007	0.229	3.14	OK
34	0.003	0.229	1.48	OK
35	0.006	0.229	2.62	OK
36	0.003	0.229	1.21	OK
37	0.004	0.229	1.69	OK
38	0.003	0.229	1.17	OK
39	0.004	0.229	1.91	OK
40	0.004	0.229	1.77	OK

Test Mode: 00

Test Result: Pass Source qualification: Normal  
 THC(A): 0.060 I-THD(%): 187.5 POHC(A): 0.023 POHC Limit(A): 0.251

Highest parameter values during test:

V RMS (Volts): 228.68	Frequency(Hz): 50.00
I Peak (Amps): 0.476	I RMS (Amps): 0.082
I Fund (Amps): 0.032	Crest Factor: 5.855
Power (Watts): 5.9	Power Factor: 0.324

Harm#	Harms(avg)	100%Limit	%of Limit	Harms(max)	150%Limit	%of Limit	Status
2	0.002	1.080	N/A	0.004	1.620	N/A	Pass
3	0.022	2.300	1.0	0.024	3.450	0.7	Pass
4	0.001	0.430	N/A	0.003	0.645	N/A	Pass
5	0.021	1.140	1.8	0.022	1.710	1.3	Pass
6	0.001	0.300	N/A	0.003	0.450	N/A	Pass
7	0.020	0.770	2.7	0.022	1.155	1.9	Pass
8	0.001	0.230	N/A	0.003	0.345	N/A	Pass
9	0.020	0.400	4.9	0.021	0.600	3.4	Pass
10	0.001	0.184	N/A	0.003	0.276	N/A	Pass
11	0.019	0.330	5.6	0.020	0.495	4.0	Pass
12	0.001	0.153	N/A	0.003	0.230	N/A	Pass
13	0.017	0.210	8.3	0.018	0.315	5.8	Pass
14	0.001	0.131	N/A	0.003	0.197	N/A	Pass
15	0.016	0.150	10.9	0.017	0.225	7.6	Pass
16	0.001	0.115	N/A	0.002	0.173	N/A	Pass
17	0.015	0.132	11.3	0.016	0.198	7.9	Pass
18	0.001	0.102	N/A	0.002	0.153	N/A	Pass
19	0.014	0.118	11.5	0.014	0.178	8.0	Pass
20	0.001	0.092	N/A	0.002	0.138	N/A	Pass
21	0.012	0.107	11.4	0.013	0.161	7.9	Pass
22	0.001	0.084	N/A	0.002	0.125	N/A	Pass
23	0.011	0.098	11.1	0.011	0.147	7.7	Pass
24	0.001	0.077	N/A	0.002	0.115	N/A	Pass
25	0.009	0.090	10.5	0.010	0.135	7.3	Pass
26	0.001	0.071	N/A	0.002	0.107	N/A	Pass
27	0.008	0.083	9.7	0.008	0.125	6.7	Pass
28	0.001	0.066	N/A	0.002	0.099	N/A	Pass
29	0.007	0.078	8.8	0.007	0.116	6.0	Pass
30	0.001	0.061	N/A	0.001	0.092	N/A	Pass
31	0.006	0.073	7.7	0.006	0.109	5.3	Pass
32	0.001	0.058	N/A	0.001	0.086	N/A	Pass
33	0.004	0.068	N/A	0.005	0.102	N/A	Pass
34	0.000	0.054	N/A	0.001	0.081	N/A	Pass
35	0.003	0.064	N/A	0.004	0.096	N/A	Pass
36	0.000	0.051	N/A	0.001	0.077	N/A	Pass
37	0.003	0.061	N/A	0.003	0.091	N/A	Pass
38	0.000	0.048	N/A	0.001	0.073	N/A	Pass
39	0.002	0.058	N/A	0.002	0.087	N/A	Pass
40	0.000	0.046	N/A	0.001	0.069	N/A	Pass

Test Mode: 01

Test Result: Pass Source qualification: Normal  
 THC(A): 0.112 I-THD(%): 165.6 POHC(A): 0.030 POHC Limit(A): 0.251

Highest parameter values during test:

V<sub>RMS</sub> (Volts): 228.68 Frequency(Hz): 50.00  
 I<sub>Peak</sub> (Amps): 0.731 I<sub>RMS</sub> (Amps): 0.148  
 I<sub>Fund</sub> (Amps): 0.068 Crest Factor: 5.053  
 Power (Watts): 11.1 Power Factor: 0.335

Harm#	Harms(avg)	100%Limit	%of Limit	Harms(max)	150%Limit	%of Limit	Status
2	0.002	1.080	N/A	0.005	1.620	N/A	Pass
3	0.045	2.300	1.9	0.048	3.450	1.4	Pass
4	0.002	0.430	N/A	0.003	0.645	N/A	Pass
5	0.043	1.140	3.8	0.045	1.710	2.6	Pass
6	0.002	0.300	N/A	0.004	0.450	N/A	Pass
7	0.042	0.770	5.4	0.043	1.155	3.8	Pass
8	0.001	0.230	N/A	0.003	0.345	N/A	Pass
9	0.039	0.400	9.8	0.040	0.600	6.7	Pass
10	0.001	0.184	N/A	0.003	0.276	N/A	Pass
11	0.036	0.330	11.0	0.037	0.495	7.6	Pass
12	0.001	0.153	N/A	0.003	0.230	N/A	Pass
13	0.033	0.210	15.8	0.034	0.315	10.8	Pass
14	0.001	0.131	N/A	0.003	0.197	N/A	Pass
15	0.030	0.150	19.9	0.031	0.225	13.6	Pass
16	0.001	0.115	N/A	0.003	0.173	N/A	Pass
17	0.026	0.132	19.9	0.027	0.198	13.6	Pass
18	0.001	0.102	N/A	0.002	0.153	N/A	Pass
19	0.023	0.118	19.2	0.023	0.178	13.1	Pass
20	0.001	0.092	N/A	0.002	0.138	N/A	Pass
21	0.019	0.107	17.8	0.020	0.161	12.1	Pass
22	0.001	0.084	N/A	0.002	0.125	N/A	Pass
23	0.016	0.098	16.0	0.016	0.147	10.9	Pass
24	0.001	0.077	N/A	0.002	0.115	N/A	Pass
25	0.012	0.090	13.7	0.013	0.135	9.4	Pass
26	0.001	0.071	N/A	0.002	0.107	N/A	Pass
27	0.009	0.083	11.2	0.010	0.125	7.8	Pass
28	0.001	0.066	N/A	0.001	0.099	N/A	Pass
29	0.007	0.078	8.5	0.007	0.116	6.1	Pass
30	0.001	0.061	N/A	0.001	0.092	N/A	Pass
31	0.004	0.073	N/A	0.005	0.109	N/A	Pass
32	0.000	0.058	N/A	0.001	0.086	N/A	Pass
33	0.003	0.068	N/A	0.004	0.102	N/A	Pass
34	0.000	0.054	N/A	0.001	0.081	N/A	Pass
35	0.002	0.064	N/A	0.002	0.096	N/A	Pass
36	0.000	0.051	N/A	0.001	0.077	N/A	Pass
37	0.002	0.061	N/A	0.002	0.091	N/A	Pass
38	0.000	0.048	N/A	0.001	0.073	N/A	Pass
39	0.002	0.058	N/A	0.003	0.087	N/A	Pass
40	0.000	0.046	N/A	0.001	0.069	N/A	Pass

Test Mode: 01

Harm#	Harmonics V-rms	Limit V-rms	% of Limit	Status
2	0.152	0.457	33.24	OK
3	0.453	2.058	22.03	OK
4	0.033	0.457	7.28	OK
5	0.036	0.915	3.99	OK
6	0.080	0.457	17.44	OK
7	0.057	0.686	8.27	OK
8	0.046	0.457	9.99	OK
9	0.016	0.457	3.53	OK
10	0.022	0.457	4.87	OK
11	0.024	0.229	10.70	OK
12	0.016	0.229	7.13	OK
13	0.021	0.229	9.38	OK
14	0.014	0.229	6.34	OK
15	0.021	0.229	9.14	OK
16	0.013	0.229	5.51	OK
17	0.020	0.229	8.70	OK
18	0.015	0.229	6.74	OK
19	0.018	0.229	7.94	OK
20	0.009	0.229	4.00	OK
21	0.016	0.229	6.89	OK
22	0.007	0.229	3.22	OK
23	0.017	0.229	7.57	OK
24	0.005	0.229	2.00	OK
25	0.013	0.229	5.66	OK
26	0.010	0.229	4.50	OK
27	0.012	0.229	5.34	OK
28	0.007	0.229	2.99	OK
29	0.007	0.229	2.97	OK
30	0.006	0.229	2.77	OK
31	0.007	0.229	3.03	OK
32	0.005	0.229	2.16	OK
33	0.005	0.229	2.14	OK
34	0.003	0.229	1.40	OK
35	0.004	0.229	1.85	OK
36	0.003	0.229	1.35	OK
37	0.005	0.229	1.99	OK
38	0.003	0.229	1.17	OK
39	0.005	0.229	2.10	OK
40	0.004	0.229	1.95	OK

## 7 Immunity Test Results

### Performance Criteria Description in EN 50130-4:2011 +A1:2014

There shall be no damage, malfunction or change of status due to the conditioning. Flickering of an indicator during the application of the discharges is permissible, providing that there is no residual change in the EUT or any change in outputs, which could be interpreted by associated equipment as a change.

For further details, please refer to Clause 7.4, 8.4, 9.4, 10.4, 11.4, 12.4 and 13.4, of EN 50130-4.

### General Performance Criteria Description in EN 55035: 2017+A11:2020

- Criterion A The equipment shall continue to operate as intended without operator intervention. No degradation of performance, loss of function or change of operating state is allowed below a performance level specified by the manufacturer when the equipment is used as intended. The performance level may be replaced by a permissible loss of performance. If the minimum performance level or the permissible performance loss is not specified by the manufacturer, then either of these may be derived from the product description and documentation, and by what the user may reasonably expect from the equipment if used as intended.
- Criterion B During the application of the disturbance, degradation of performance is allowed. However, no unintended change of actual operating state or stored data is allowed to persist after the test.  
After the test, the equipment shall continue to operate as intended without operator intervention; no degradation of performance or loss of function is allowed, below a performance level specified by the manufacturer, when the equipment is used as intended. The performance level may be replaced by a permissible loss of performance. If the minimum performance level (or the permissible performance loss), or recovery time, is not specified by the manufacturer, then either of these may be derived from the product description and documentation, and by what the user may reasonably expect from the equipment if used as intended.
- Criterion C Loss of function is allowed, provided the function is self-recoverable, or can be restored by the operation of the controls by the user in accordance with the manufacturer's instructions. A reboot or re-start operation is allowed.  
Information stored in non-volatile memory, or protected by a battery backup, shall not be lost.

## 7.1 Electrostatic Discharge

Test Requirement: EN 50130-4: 2011 +A1:2014

Test Method: EN 61000-4-2:2009

### 7.1.1 Test Setup Diagram

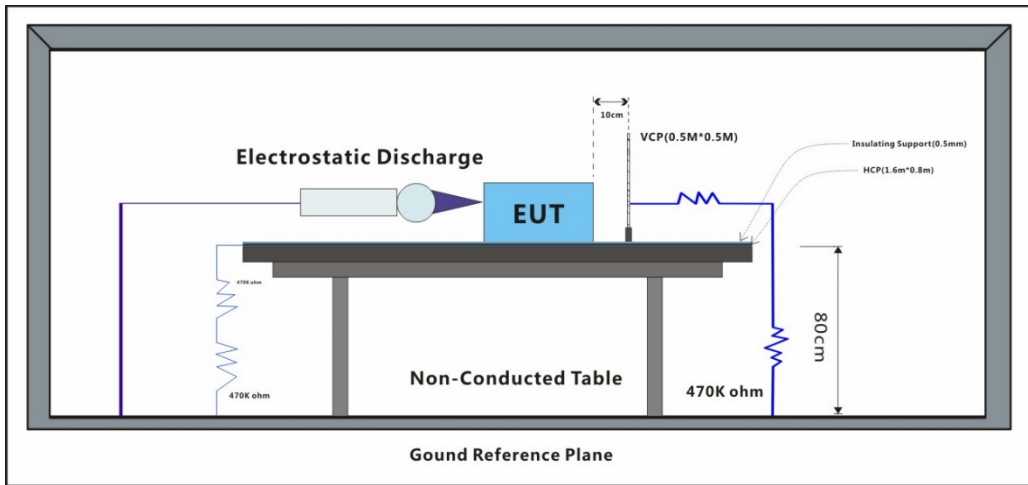

### 7.1.2 E.U.T. Operation

Operating Environment:

Temperature: 24.5 °C

Humidity: 51.2 % RH

Atmospheric Pressure: 1010 mbar

### 7.1.3 Test Mode Description

Pre-scan / Final test	Mode Code	Description
Final test	00	Keep EUT working normally with DC12V Adapter.
Final test	01	Keep EUT working normally with PoE Adapter.

**7.1.4 Test Condition and Results:**

Number of Discharge: Minimum 10 times at each test point for Air Discharge; Minimum 50 times at each test point for Contact or VCP & HCP Discharge

Discharge Mode: Single Discharge

Discharge Period: 1 second minimum

Test Point 1: All insulated enclosure & seams.

Test Point 2: All accessible metal parts of the enclosure.

Test Point 3: All sides.

Discharge type	Level (kV)	Polarity	Test Point	Result / Observations
Air Discharge	2,4,8	+	1	A
Air Discharge	2,4,8	-	1	A
Contact Discharge	6	+	2	A
Contact Discharge	6	-	2	A
Horizontal Coupling	6	+	3	A
Horizontal Coupling	6	-	3	A
Vertical Coupling	6	+	3	A
Vertical Coupling	6	-	3	A

A: No degradation in the performance of the EUT was observed

## 7.2 Radiated Immunity(80MHz-2.7GHz)

Test Requirement: EN 50130-4: 2011 +A1:2014

Test Method: EN IEC 61000-4-3: 2020

### 7.2.1 Test Setup Diagram

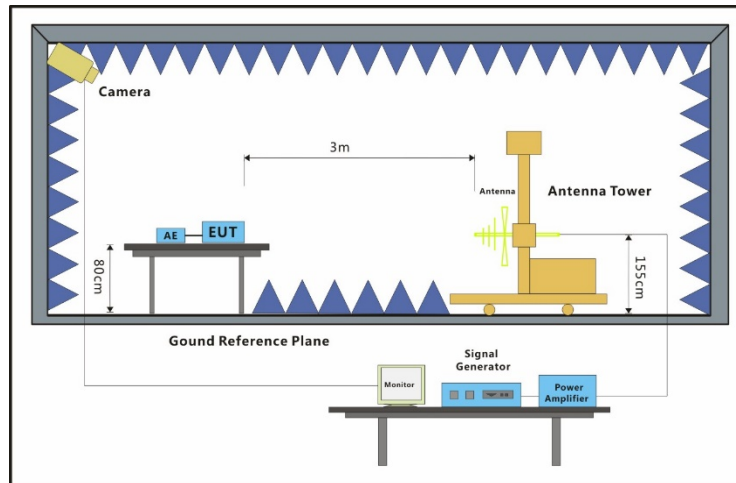

### 7.2.2 E.U.T. Operation

Operating Environment:

Temperature: 25 °C

Humidity: 49 % RH

Atmospheric Pressure: 1010 mbar

### 7.2.3 Test Mode Description

Pre-scan / Final test	Mode Code	Description
Final test	00	Keep EUT working normally with DC12V Adapter.
Final test	01	Keep EUT working normally with PoE Adapter.

### 7.2.4 Test Condition and Results:

Modulation: 80%, 1 kHz Amplitude Modulation & 0.5s ON 0.5s OFF Pulse Modulation

Frequency	Level (V/m)	EUT Face	Dwell time	Result / Observations
80MHz-2.7GHz	10	Front	3s	A
80MHz-2.7GHz	10	Back	3s	A
80MHz-2.7GHz	10	Left	3s	A
80MHz-2.7GHz	10	Right	3s	A
80MHz-2.7GHz	10	Top	3s	A
80MHz-2.7GHz	10	Underside	3s	A

A: No degradation in the performance of the EUT was observed

### 7.3 Electrical Fast Transients & Burst at AC Power Port

Test Requirement: EN 50130-4: 2011 +A1:2014

Test Method: EN 61000-4-4:2012

#### 7.3.1 Test Setup Diagram

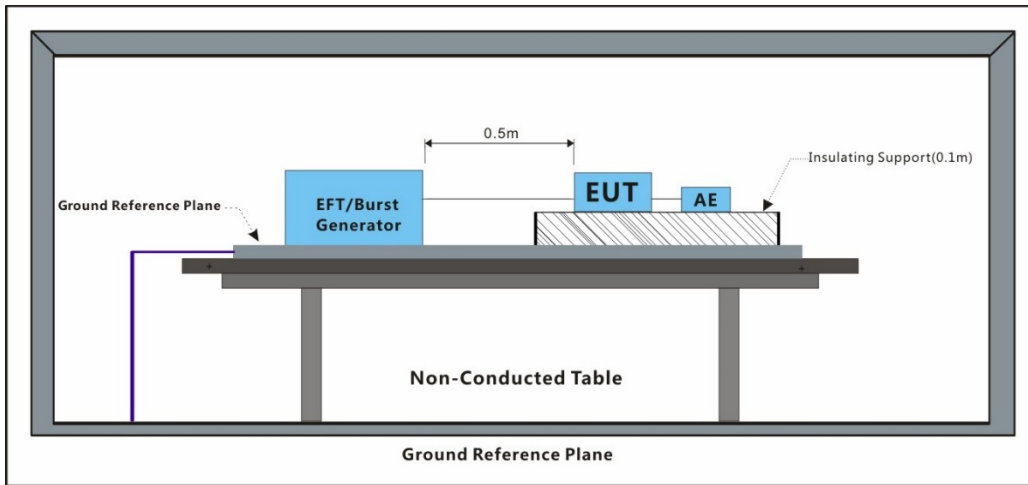

#### 7.3.2 E.U.T. Operation

Operating Environment:

Temperature: 24.5 °C

Humidity: 51.2 % RH

Atmospheric Pressure: 1010 mbar

#### 7.3.3 Test Mode Description

Pre-scan / Final test	Mode Code	Description
Final test	00	Keep EUT working normally with DC12V Adapter.
Final test	01	Keep EUT working normally with PoE Adapter.

#### 7.3.4 Test Condition and Results:

Repetition Frequency: 100kHz

Burst Period: 300ms

Test Duration: 1 minute per level & polarity

Test Line	Level (kV)	Polarity	CDN/Clamp	Result / Observations
AC power port	2	+	CDN	A
AC power port	2	-	CDN	A

A: No degradation in the performance of the EUT was observed

## 7.4 Electrical Fast Transients & Burst at Signal Port

Test Requirement: EN 50130-4: 2011 +A1:2014

Test Method: EN 61000-4-4:2012

### 7.4.1 Test Setup Diagram

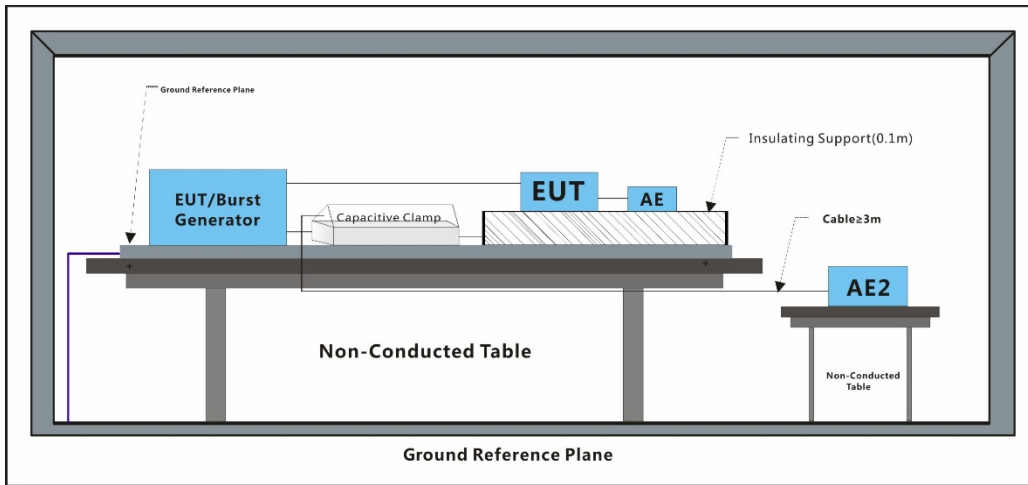

### 7.4.2 E.U.T. Operation

Operating Environment:

Temperature: 24.5 °C

Humidity: 51.2 % RH

Atmospheric Pressure: 1010 mbar

### 7.4.3 Test Mode Description

Pre-scan / Final test	Mode Code	Description
Final test	00	Keep EUT working normally with DC12V Adapter.
Final test	01	Keep EUT working normally with PoE Adapter.

### 7.4.4 Test Condition and Results:

Repetition Frequency: 100kHz

Burst Period: 300ms

Test Duration: 1 minute per level & polarity

Test Line	Level (kV)	Polarity	CDN/Clamp	Result / Observations
Signal Port	1	+	Clamp	A
Signal Port	1	-	Clamp	A

A: No degradation in the performance of the EUT was observed

## 7.5 Surge at AC Power Port

Test Requirement: EN 50130-4: 2011 +A1:2014

Test Method: EN 61000-4-5:2014 +A1:2017

### 7.5.1 Test Setup Diagram

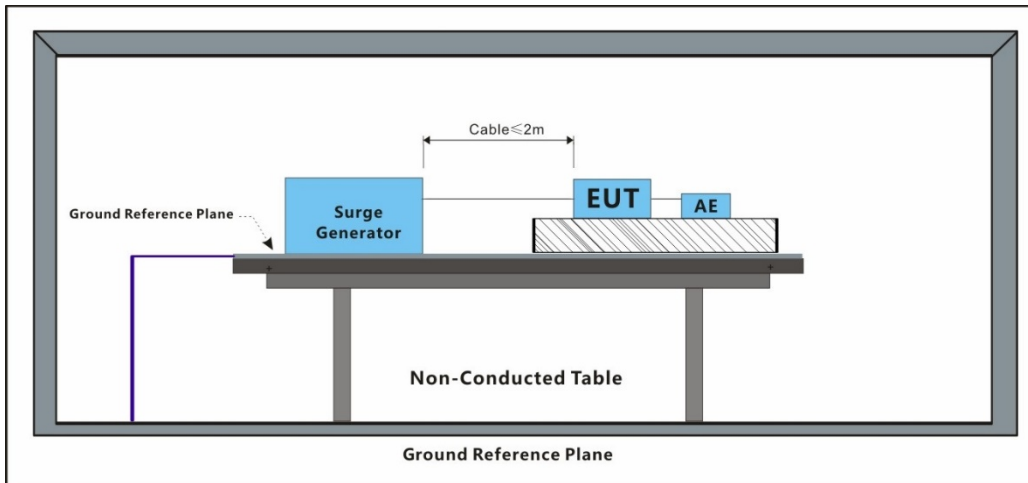

### 7.5.2 E.U.T. Operation

Operating Environment:

Temperature: 24.5 °C

Humidity: 51.2 % RH

Atmospheric Pressure: 1010 mbar

### 7.5.3 Test Mode Description

Pre-scan / Final test	Mode Code	Description
Final test	00	Keep EUT working normally with DC12V Adapter.
Final test	01	Keep EUT working normally with PoE Adapter.

**7.5.4 Test Condition and Results:**

Interval: 60s between each surge

No. of surges: 5 positive, 5 negative

Test Line	Level (kV)	Polarity	Phase (deg)	Result / Observations
L-N	0.5,1	+	0°	A
L-N	0.5,1	-	0°	A
L-N	0.5,1	+	90°	A
L-N	0.5,1	-	90°	A
L-N	0.5,1	+	180°	A
L-N	0.5,1	-	180°	A
L-N	0.5,1	+	270°	A
L-N	0.5,1	-	270°	A
L-PE	0.5,1,2	+	0°	A
L-PE	0.5,1,2	-	0°	A
L-PE	0.5,1,2	+	90°	A
L-PE	0.5,1,2	-	90°	A
L-PE	0.5,1,2	+	180°	A
L-PE	0.5,1,2	-	180°	A
L-PE	0.5,1,2	+	270°	A
L-PE	0.5,1,2	-	270°	A
N-PE	0.5,1,2	+	0°	A
N-PE	0.5,1,2	-	0°	A
N-PE	0.5,1,2	+	90°	A
N-PE	0.5,1,2	-	90°	A
N-PE	0.5,1,2	+	180°	A
N-PE	0.5,1,2	-	180°	A
N-PE	0.5,1,2	+	270°	A
N-PE	0.5,1,2	-	270°	A

A: No degradation in the performance of the EUT was observed

## 7.6 Surge at Signal Port

Test Requirement: EN 50130-4: 2011 +A1:2014

Test Method: EN 61000-4-5:2014 +A1:2017

### 7.6.1 Test Setup Diagram

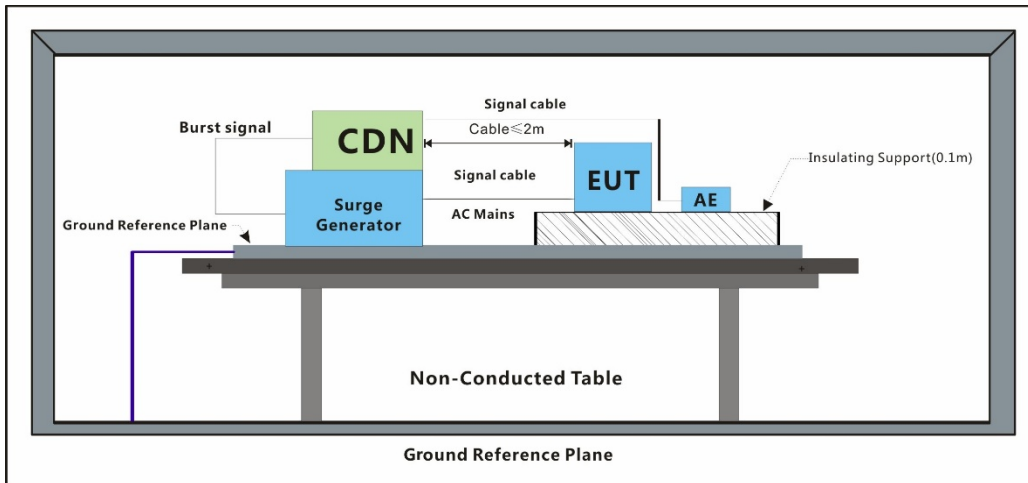

### 7.6.2 E.U.T. Operation

Operating Environment:

Temperature: 24.5 °C

Humidity: 51.2 % RH

Atmospheric Pressure: 1010 mbar

### 7.6.3 Test Mode Description

Pre-scan / Final test	Mode Code	Description
Final test	00	Keep EUT working normally with DC12V Adapter.
Final test	01	Keep EUT working normally with PoE Adapter.

### 7.6.4 Test Condition and Results:

Interval: 60s between each surge

No. of surges: 5 positive, 5 negative.

Port	Line	Level (kV)	Polarity	Result / Observations
Signal port	Line-Ground	0.5	+	A
Signal port	Line-Ground	0.5	-	A
Signal port	Line-Ground	1	+	A
Signal port	Line-Ground	1	-	A

A: No degradation in the performance of the EUT was observed

### 7.7 Conducted Immunity at Power Port (150kHz-100MHz)

Test Requirement: EN 50130-4: 2011 +A1:2014

Test Method: EN 61000-4-6:2014

#### 7.7.1 Test Setup Diagram

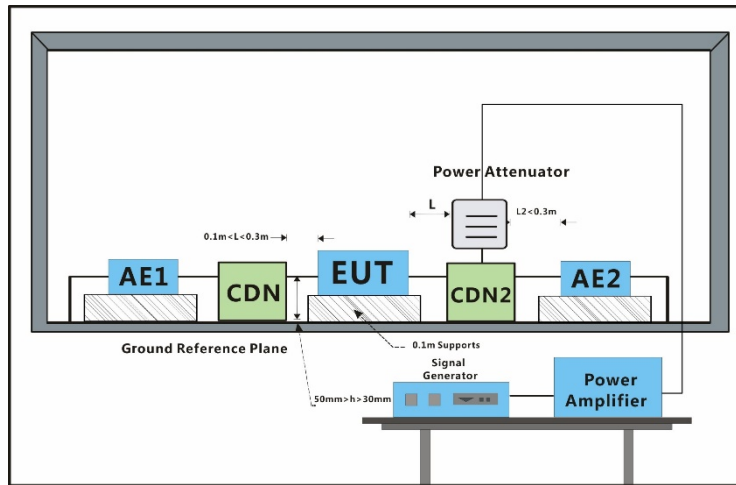

#### 7.7.2 E.U.T. Operation

Operating Environment:

Temperature: 24.5 °C

Humidity: 51.2 % RH

Atmospheric Pressure: 1010 mbar

#### 7.7.3 Test Mode Description

Pre-scan / Final test	Mode Code	Description
Final test	00	Keep EUT working normally with DC12V Adapter.
Final test	01	Keep EUT working normally with PoE Adapter.

#### 7.7.4 Test Condition and Results:

Modulation: 80%, 1 kHz Amplitude Modulation & 0.5s ON 0.5s OFF Pulse Modulation

Cable port	Level (Vrms)	CDN/Clamp	Dwell time	Result / Observations
AC power port	10	CDN	3s	A
A: No degradation in the performance of the EUT was observed				

### 7.8 Conducted Immunity at Signal Port (150kHz-100MHz)

Test Requirement: EN 50130-4: 2011 +A1:2014

Test Method: EN 61000-4-6:2014

#### 7.8.1 Test Setup Diagram

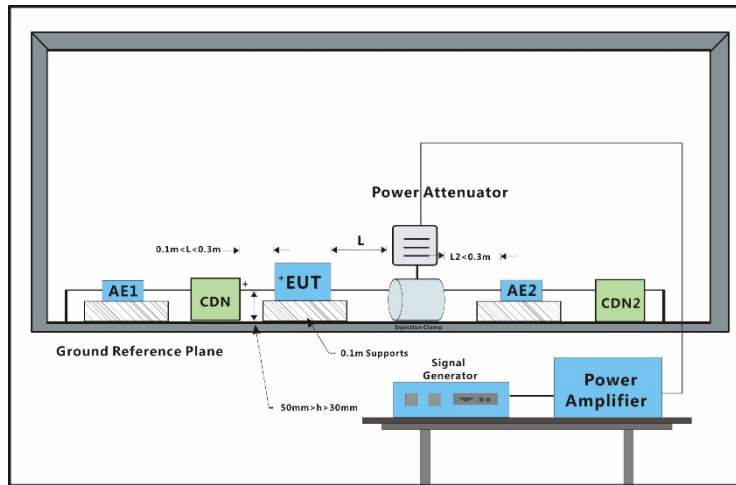

#### 7.8.2 E.U.T. Operation

Operating Environment:

Temperature: 24.5 °C

Humidity: 51.2 % RH

Atmospheric Pressure: 1010 mbar

#### 7.8.3 Test Mode Description

Pre-scan / Final test	Mode Code	Description
Final test	00	Keep EUT working normally with DC12V Adapter.
Final test	01	Keep EUT working normally with PoE Adapter.

#### 7.8.4 Test Condition and Results:

Modulation: 80%, 1 kHz Amplitude Modulation & 0.5s ON 0.5s OFF Pulse Modulation

Cable port	Level (Vrms)	CDN/Clamp	Dwell time	Result / Observations
Signal or Control port	10	CDN	3s	A

A: No degradation in the performance of the EUT was observed

## 7.9 Mains Supply Voltage Variations

Test Requirement: EN 50130-4: 2011 +A1:2014

Test Method: EN 50130-4:2011+A1:2014

### 7.9.1 Test Setup Diagram

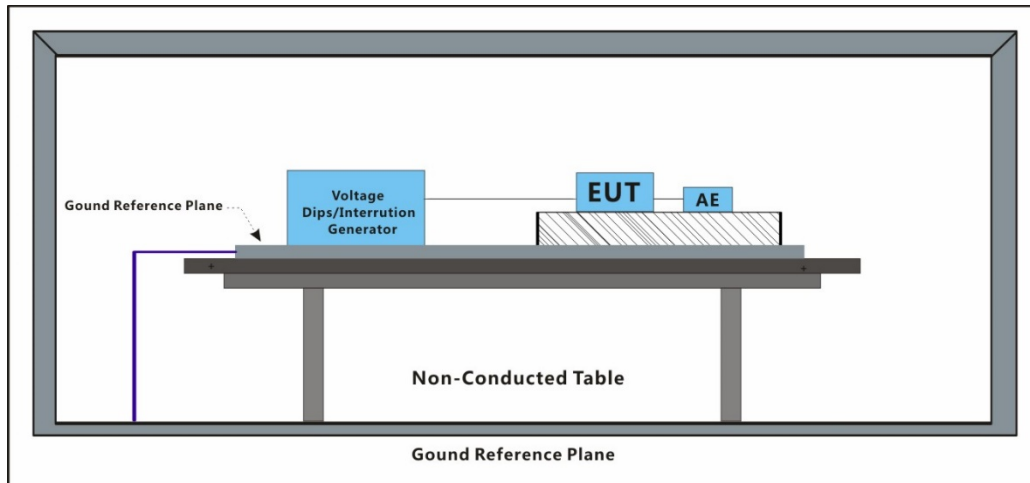

### 7.9.2 E.U.T. Operation

Operating Environment:

Temperature: 24.5 °C

Humidity: 51.2 % RH

Atmospheric Pressure: 1010 mbar

### 7.9.3 Test Mode Description

Pre-scan / Final test	Mode Code	Description
Final test	00	Keep EUT working normally with DC12V Adapter.
Final test	01	Keep EUT working normally with PoE Adapter.

### 7.9.4 Test Condition and Results:

Voltage max.: AC 264V (Umax: Unom + 10%)

Voltage min.: AC 85V (Umin: Unom - 15%)

Unom Voltage: AC 100-240V

Test phenomenon description for the EUT:

1. The EUT working normal, before the conditioning.
  2. Monitor the EUT during the conditioning period and detected no any changes in states, during the conditioning.
  3. No degradation in the performance of the EUT was observed, after the conditioning.
- A: No degradation in the performance of the EUT was observed

## 7.10 Voltage Dips and Interruptions

Test Requirement: EN 50130-4: 2011 +A1:2014

Test Method: EN IEC 61000-4-11:2020

### 7.10.1 Test Setup Diagram

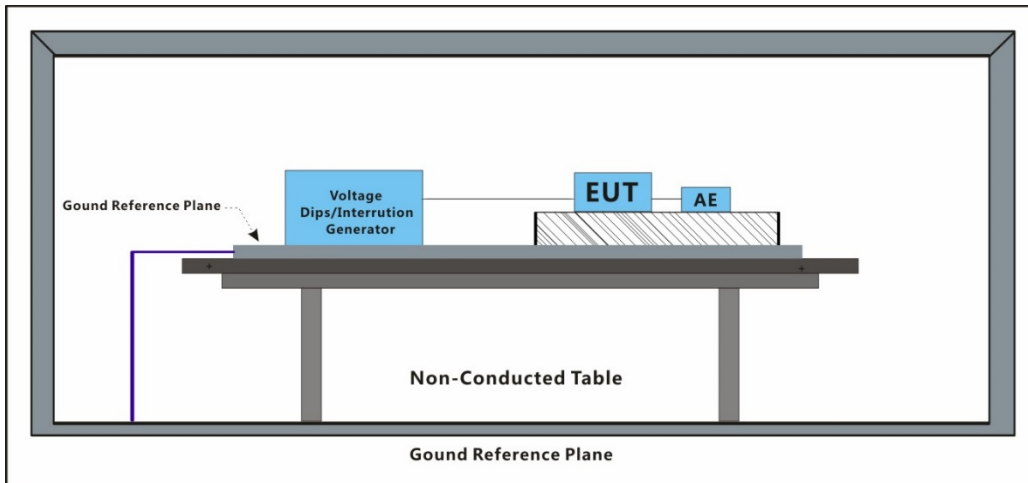

### 7.10.2 E.U.T. Operation

Operating Environment:

Temperature: 24.5 °C

Humidity: 51.2 % RH

Atmospheric Pressure: 1010 mbar

### 7.10.3 Test Mode Description

Pre-scan / Final test	Mode Code	Description
Final test	00	Keep EUT working normally with DC12V Adapter.
Final test	01	Keep EUT working normally with PoE Adapter.

**7.10.4 Test Condition and Results:**

Performance Criterion:

0% of UT (Supply Voltage) for 250 Periods;

40% of UT for 10 Periods;

70% of UT for 25 Periods; 80% of UT for 250 Periods;

No. of Dips / Interruptions: 3 per Level

Time between dropout 10s

Level % UT	Phase (deg)	Duration	No. of Dips / Interruptions	Result / Observations
80	0°	250 Cycles	3	A
80	180°	250 Cycles	3	A
70	0°	25 Cycles	3	A
70	180°	25 Cycles	3	A
40	0°	10 Cycles	3	A
40	180°	10 Cycles	3	A
0	0°	250 Cycles	3	B
0	180°	250 Cycles	3	B

A: No degradation in the performance of the EUT was observed  
 B: During the test,the EUT working abnormally.  
 After the test,the EUT automatically recovering working normally.

## 7.11 Electrostatic Discharge

Test Requirement: EN 55035: 2017+A11:2020

Test Method: EN 61000-4-2: 2009

### 7.11.1 Test Setup Diagram

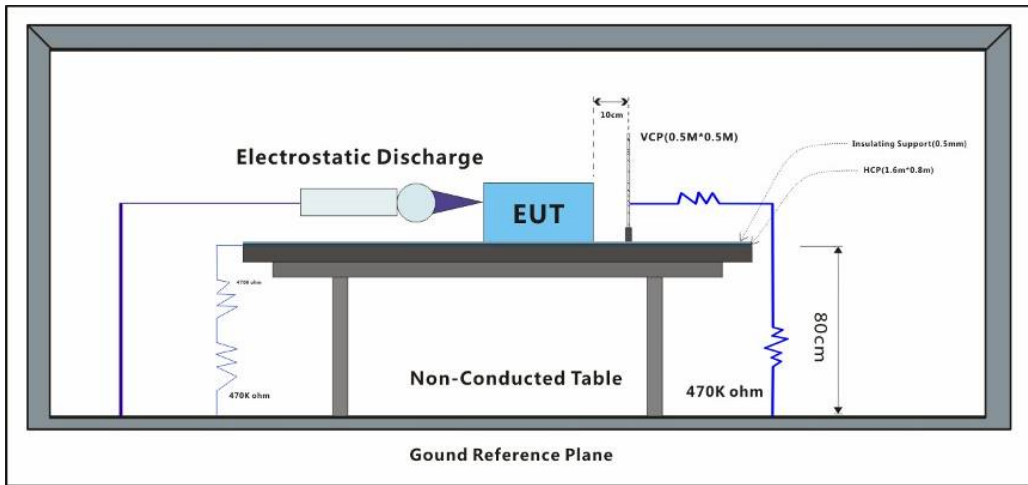

### 7.11.2 E.U.T. Operation

Operating Environment:

Temperature: 24.5 °C

Humidity: 51.2 % RH

Atmospheric Pressure: 1010 mbar

### 7.11.3 Test Mode Description

Pre-scan / Final test	Mode Code	Description
Final test	00	Keep EUT working normally with DC12V Adapter.
Final test	01	Keep EUT working normally with PoE Adapter.

**7.11.4 Test Condition and Results:**

Performance Criterion: B  
 Discharge Impedance: 330Ω/150pF  
 Number of Discharge: Minimum 10 times at each test point  
 Discharge Mode: Single Discharge  
 Discharge Period: 1 second minimum  
 Test Point 1: All insulated enclosure & seams.  
 Test Point 2: All accessible metal parts of the enclosure.  
 Test Point 3: All sides.

Discharge type	Level (kV)	Polarity	Test Point	Result / Observations
Air Discharge	2,4,8	+	1	A
Air Discharge	2,4,8	-	1	A
Contact Discharge	4	+	2	A
Contact Discharge	4	-	2	A
Horizontal Coupling	4	+	3	A
Horizontal Coupling	4	-	3	A
Vertical Coupling	4	+	3	A
Vertical Coupling	4	-	3	A
A: No degradation in the performance of the EUT was observed				

### 7.12 Radiated Immunity (80MHz-1GHz,1800MHz,2600MHz,3500MHz,5000MHz)

Test Requirement: EN 55035: 2017+A11:2020

Test Method: EN IEC 61000-4-3: 2020

#### 7.12.1 Test Setup Diagram

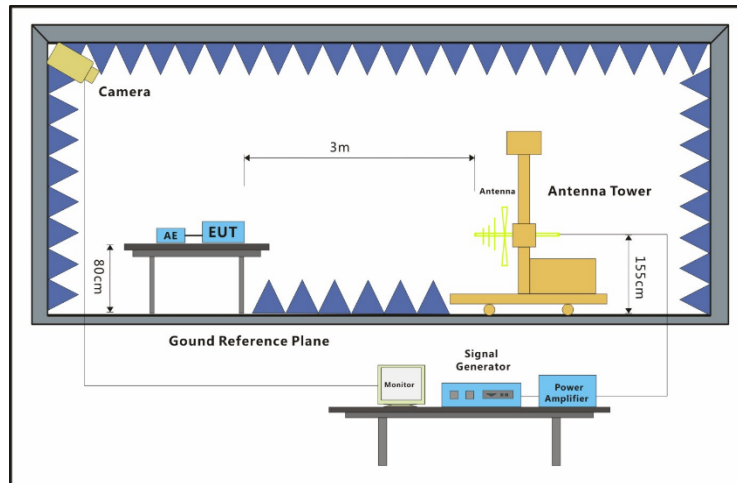

#### 7.12.2 E.U.T. Operation

Operating Environment:

Temperature: 25 °C

Humidity: 49 % RH

Atmospheric Pressure: 1010 mbar

#### 7.12.3 Test Mode Description

Pre-scan / Final test	Mode Code	Description
Final test	00	Keep EUT working normally with DC12V Adapter.
Final test	01	Keep EUT working normally with PoE Adapter.

**7.12.4 Test Condition and Results:**

Performance Criterion: A

Frequency Range: 80MHz to 1GHz, 1800MHz, 2600MHz, 3500MHz, 5000MHz

Antenna Polarisation: Vertical and Horizontal

Modulation: 1kHz,80% Amp. Mod,1% increment

Test Distance:3m

Frequency	Level (V/m)	EUT Face	Dwell time	Result / Observations
80MHz-1GHz	3	Front	3s	A
80MHz-1GHz	3	Back	3s	A
80MHz-1GHz	3	Left	3s	A
80MHz-1GHz	3	Right	3s	A
80MHz-1GHz	3	Top	3s	A
80MHz-1GHz	3	Underside	3s	A
1800MHz	3	Front	3s	A
1800MHz	3	Back	3s	A
1800MHz	3	Left	3s	A
1800MHz	3	Right	3s	A
1800MHz	3	Top	3s	A
1800MHz	3	Underside	3s	A
2600MHz	3	Front	3s	A
2600MHz	3	Back	3s	A
2600MHz	3	Left	3s	A
2600MHz	3	Right	3s	A
2600MHz	3	Top	3s	A
2600MHz	3	Underside	3s	A
3500MHz	3	Front	3s	A
3500MHz	3	Back	3s	A
3500MHz	3	Left	3s	A
3500MHz	3	Right	3s	A
3500MHz	3	Top	3s	A
3500MHz	3	Underside	3s	A
5000MHz	3	Front	3s	A
5000MHz	3	Back	3s	A
5000MHz	3	Left	3s	A
5000MHz	3	Right	3s	A
5000MHz	3	Top	3s	A
5000MHz	3	Underside	3s	A

A: No degradation in the performance of the EUT was observed

### 7.13 Electrical Fast Transients & Burst at AC Power Port

Test Requirement: EN 55035: 2017+A11:2020

Test Method: EN 61000-4-4: 2012

#### 7.13.1 Test Setup Diagram

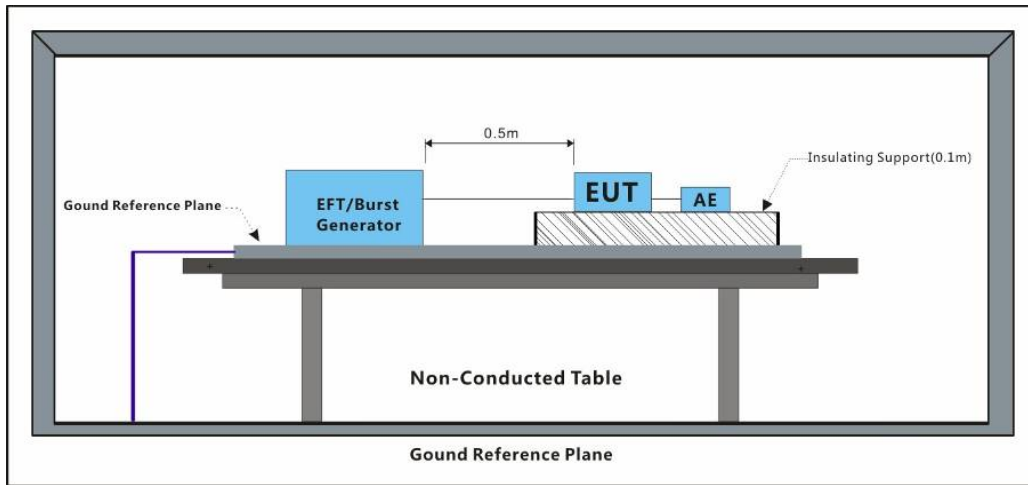

#### 7.13.2 E.U.T. Operation

Operating Environment:

Temperature: 24.5 °C

Humidity: 51.2 % RH

Atmospheric Pressure: 1010 mbar

#### 7.13.3 Test Mode Description

Pre-scan / Final test	Mode Code	Description
Final test	00	Keep EUT working normally with DC12V Adapter.
Final test	01	Keep EUT working normally with PoE Adapter.

#### 7.13.4 Test Condition and Results:

Performance Criterion: B

Repetition Frequency: 5kHz

Burst Period: 300ms

Test Duration: 2 minute per level & polarity

Test Line	Level (kV)	Polarity	CDN/Clamp	Result / Observations
AC power port	1	+	CDN	A
AC power port	1	-	CDN	A

A: No degradation in the performance of the EUT was observed

## 7.14 Electrical Fast Transients & Burst at Signal Port

Test Requirement: EN 55035: 2017+A11:2020

Test Method: EN 61000-4-4: 2012

### 7.14.1 Test Setup Diagram

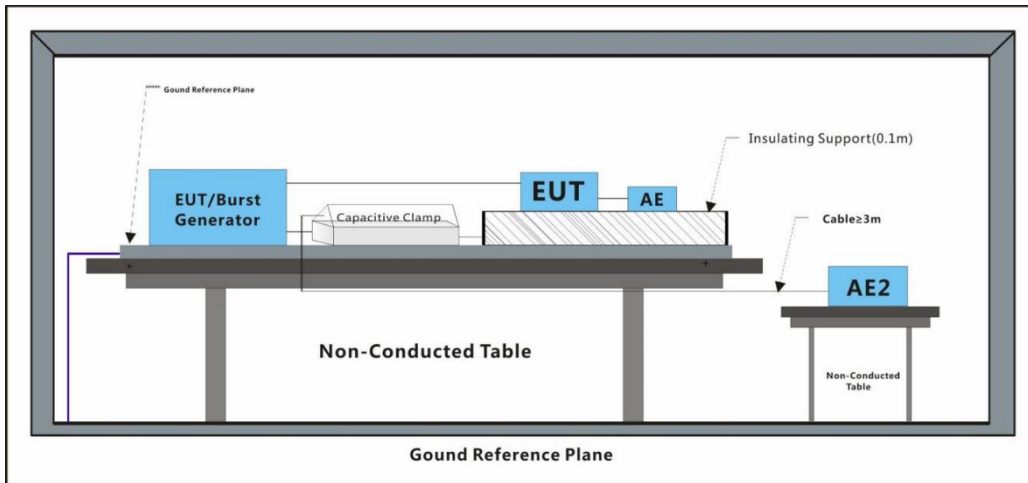

### 7.14.2 E.U.T. Operation

Operating Environment:

Temperature: 24.5 °C

Humidity: 51.2 % RH

Atmospheric Pressure: 1010 mbar

### 7.14.3 Test Mode Description

Pre-scan / Final test	Mode Code	Description
Final test	00	Keep EUT working normally with DC12V Adapter.
Final test	01	Keep EUT working normally with PoE Adapter.

### 7.14.4 Test Condition and Results:

Performance Criterion: B

Repetition Frequency: 5kHz

Burst Period: 300ms

Test Duration: 2 minute per level & polarity

Port	Level (kV)	Polarity	CDN/Clamp	Result / Observations
Signal port	0.5	+	Clamp	A
Signal port	0.5	-	Clamp	A

A: No degradation in the performance of the EUT was observed

### 7.15 Surge at AC Power Port

Test Requirement: EN 55035: 2017+A11:2020

Test Method: EN 61000-4-5: 2014 +A1: 2017

#### 7.15.1 Test Setup Diagram

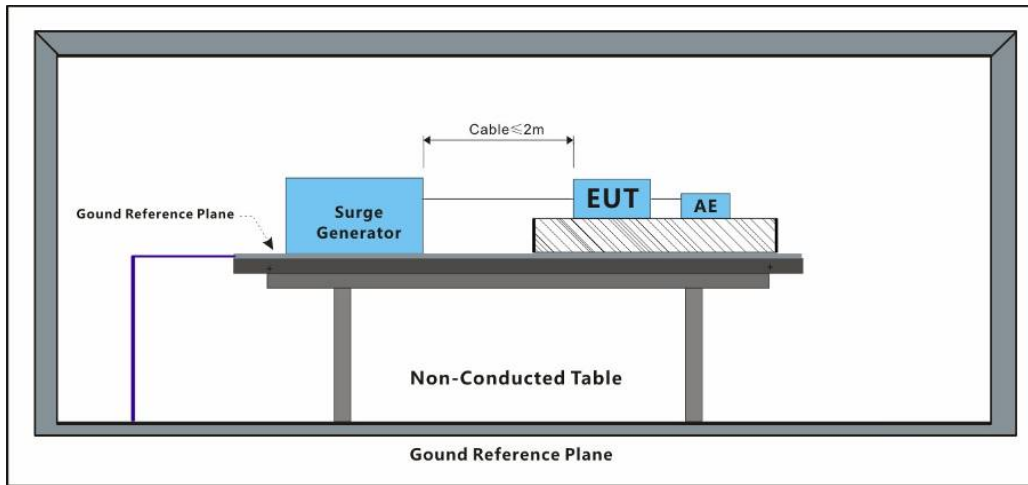

#### 7.15.2 E.U.T. Operation

Operating Environment:

Temperature: 24.5 °C

Humidity: 51.2 % RH

Atmospheric Pressure: 1010 mbar

#### 7.15.3 Test Mode Description

Pre-scan / Final test	Mode Code	Description
Final test	00	Keep EUT working normally with DC12V Adapter.
Final test	01	Keep EUT working normally with PoE Adapter.

**7.15.4 Test Condition and Results:**

Performance Criterion: B

Interval: 60s between each surge

Generator source impedance: 2Ω

CDN coupling impedance(Line-to-ground):10Ω

No. of surges:

Five positive pulses line-to-neutral at 90° phase

Five negative pulses line-to-neutral at 270° phase

Five positive pulses line-to-earth at 90° phase

Five negative pulses line-to-earth at 270° phase

Five negative pulses neutral-to-earth at 90° phase

Five positive pulses neutral-to-earth at 270° phase

Test Line	Level (kV)	Polarity	Phase (deg)	Result / Observations
L-N	1	+	90°	A
L-N	1	-	270°	A
L-PE	2	+	90°	A
L-PE	2	-	270°	A
N-PE	2	-	90°	A
N-PE	2	+	270°	A

A: No degradation in the performance of the EUT was observed

## 7.16 Surge at Signal Port

Test Requirement: EN 55035: 2017+A11:2020  
 Test Method: EN 61000-4-5: 2014 +A1: 2017

### 7.16.1 Test Setup Diagram

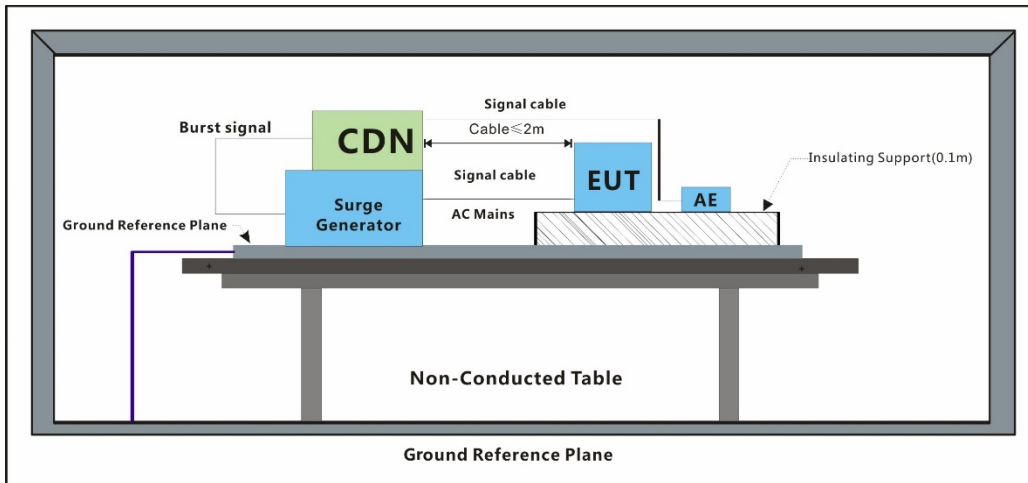

### 7.16.2 E.U.T. Operation

Operating Environment:  
 Temperature: 24.5 °C      Humidity: 51.2 % RH      Atmospheric Pressure: 1010 mbar

### 7.16.3 Test Mode Description

Pre-scan / Final test	Mode Code	Description
Final test	00	Keep EUT working normally with DC12V Adapter.
Final test	01	Keep EUT working normally with PoE Adapter.

### 7.16.4 Test Condition and Results:

Performance Criterion: B  
 Interval: 60s between each surge  
 Generator source impedance: 2Ω

Port	Line	Waveform(μs)	Level (kV)	Polarity	Result / Observations
Signal port	Line-Ground	1,2/50 (8/20)	0.5, 1	+	A
Signal port	Line-Ground	1,2/50 (8/20)	0.5, 1	-	A

A: No degradation in the performance of the EUT was observed

## 7.17 Conducted Immunity at AC Power Port (150kHz-80MHz)

Test Requirement: EN 55035: 2017+A11:2020

Test Method: EN 61000-4-6: 2014

### 7.17.1 Test Setup Diagram

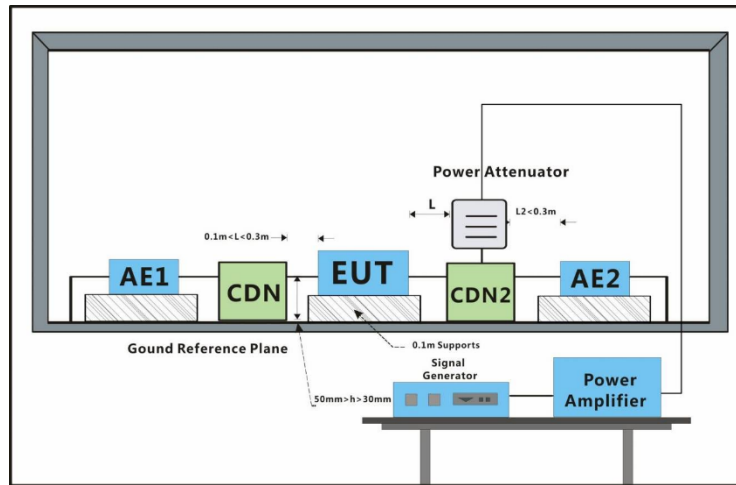

### 7.17.2 E.U.T. Operation

Operating Environment:

Temperature: 24.5 °C

Humidity: 51.2 % RH

Atmospheric Pressure: 1010 mbar

### 7.17.3 Test Mode Description

Pre-scan / Final test	Mode Code	Description
Final test	00	Keep EUT working normally with DC12V Adapter.
Final test	01	Keep EUT working normally with PoE Adapter.

### 7.17.4 Test Condition and Results:

Performance Criterion: A

Frequency Range: 0.15MHz to 80MHz

Modulation: 80%, 1kHz Amplitude Modulation

Step Size: 1%

Cable port	Level (Vrms)	CDN/Clamp	Dwell time	Result / Observations
AC power port	3(0.15MHz-10MHz)	CDN	3s	A
AC power port	3 to 1(10MHz-30MHz, Lines)	CDN	3s	A
AC power port	1(30MHz-80MHz)	CDN	3s	A

A: No degradation in the performance of the EUT was observed

### 7.18 Conducted Immunity at Signal Port (150kHz-80MHz)

Test Requirement: EN 55035: 2017+A11:2020  
 Test Method: EN 61000-4-6: 2014

#### 7.18.1 Test Setup Diagram

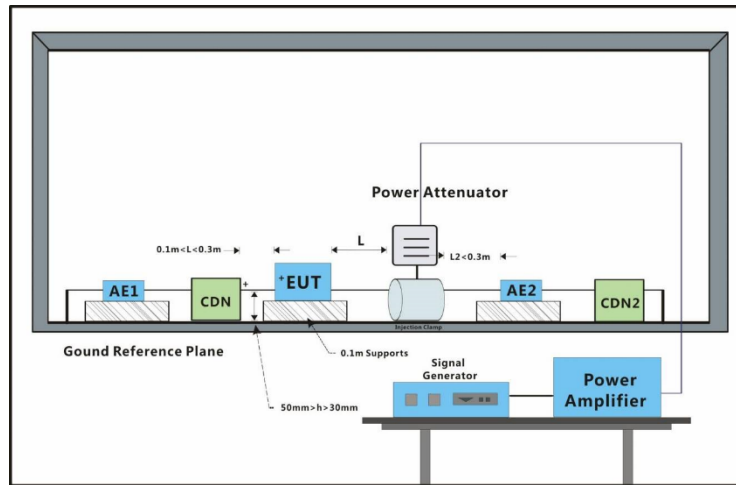

#### 7.18.2 E.U.T. Operation

Operating Environment:

Temperature: 24.5 °C

Humidity: 51.2 % RH

Atmospheric Pressure: 1010 mbar

#### 7.18.3 Test Mode Description

Pre-scan / Final test	Mode Code	Description
Final test	00	Keep EUT working normally with DC12V Adapter.
Final test	01	Keep EUT working normally with PoE Adapter.

#### 7.18.4 Test Condition and Results:

Performance Criterion: A

Frequency Range: 0.15MHz to 80MHz

Modulation: 80%, 1kHz Amplitude Modulation

Step Size: 1%

Port	Level (Vrms)	CDN/Clamp	Dwell time	Result / Observations
Signal port	3(0.15MHz-10MHz)	Clamp	3s	A
Signal port	3 to 1(10MHz-30MHz, Lines)	Clamp	3s	A
Signal port	1(30MHz-80MHz)	Clamp	3s	A

A: No degradation in the performance of the EUT was observed

### 7.19 Power Frequency Magnetic Field

Test Requirement: EN 55035: 2017+A11:2020  
 Test Method: EN 61000-4-8: 2010

#### 7.19.1 Test Setup Diagram

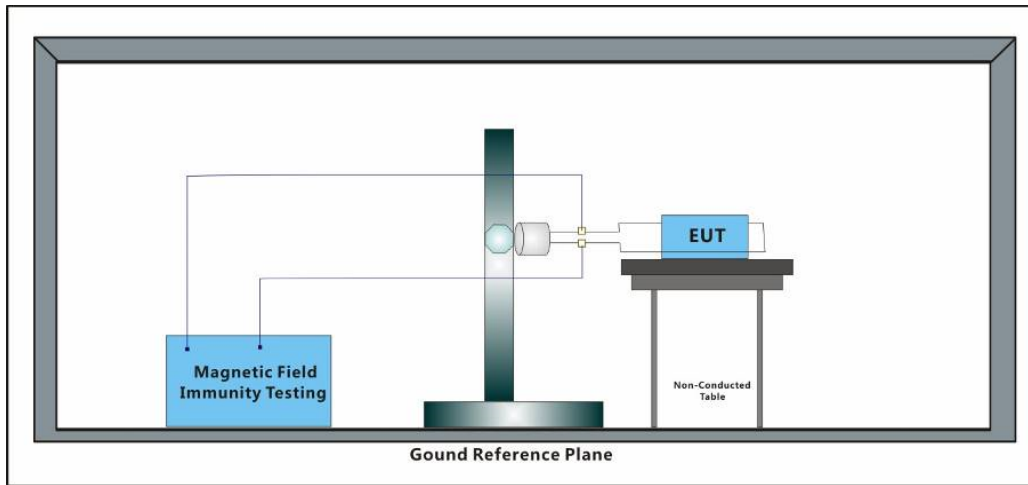

#### 7.19.2 E.U.T. Operation

Operating Environment:

Temperature: 24.5 °C      Humidity: 51.2 % RH      Atmospheric Pressure: 1010 mbar

#### 7.19.3 Test Mode Description

Pre-scan / Final test	Mode Code	Description
Final test	00	Keep EUT working normally with DC12V Adapter.
Final test	01	Keep EUT working normally with PoE Adapter.

#### 7.19.4 Test Condition and Results:

Performance Criterion: A

Frequency	Level (A/m)	Axial	Magnetic Field Type	Result / Observations
50Hz	1	X	Continuous filed	A
50Hz	1	Y	Continuous filed	A
50Hz	1	Z	Continuous filed	A

A: No degradation in the performance of the EUT was observed

## 7.20 Voltage Dips and Interruptions

Test Requirement: EN 55035: 2017+A11:2020

Test Method: EN IEC 61000-4-11:2020

### 7.20.1 Test Setup Diagram

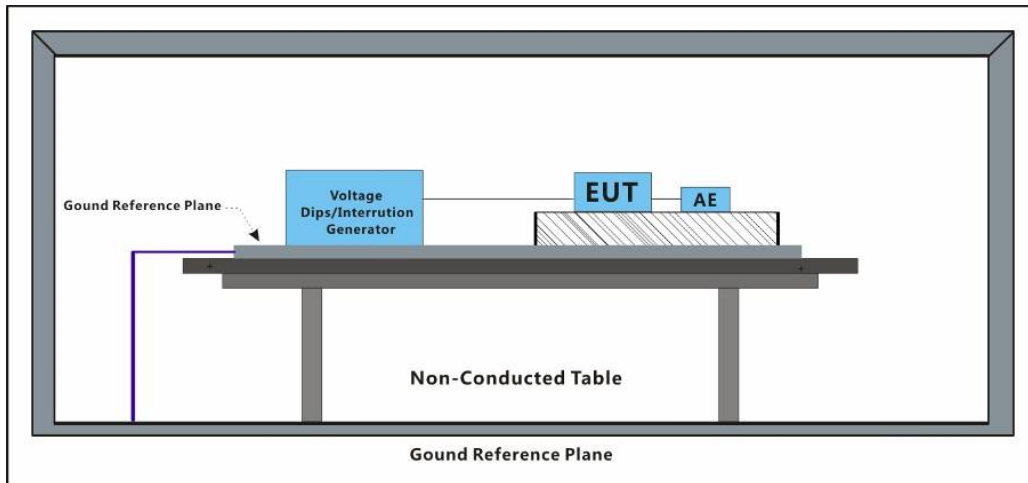

### 7.20.2 E.U.T. Operation

Operating Environment:

Temperature: 24.5 °C

Humidity: 51.2 % RH

Atmospheric Pressure: 1010 mbar

### 7.20.3 Test Mode Description

Pre-scan / Final test	Mode Code	Description
Final test	00	Keep EUT working normally with DC12V Adapter.
Final test	01	Keep EUT working normally with PoE Adapter.

**7.20.4 Test Condition and Results:**

Performance Criterion:

<5% residual voltage for 0.5 Cycle: B

70% residual voltage for 25 Cycles: C

<5% residual voltage for 250 Cycles: C

No. of Dips / Interruptions: 3 per Level

Time between dropout: 10s

Level % UT	Phase (deg)	Duration	No. of Dips / Interruptions	Result / Observations
0	0°	0.5 Cycles	3	A
0	0°	250 Cycles	3	A
70	0°	25 Cycles	3	A

A: No degradation in the performance of the EUT was observed

B: During the test,the EUT working abnormally.

After the test,the EUT automatically recovering working normally.

## 8 Test Setup Photo

### Conducted Emissions at Mains Power Port (150kHz-30MHz)



## Asymmetric Mode Conducted Emissions(150kHz-30MHz)

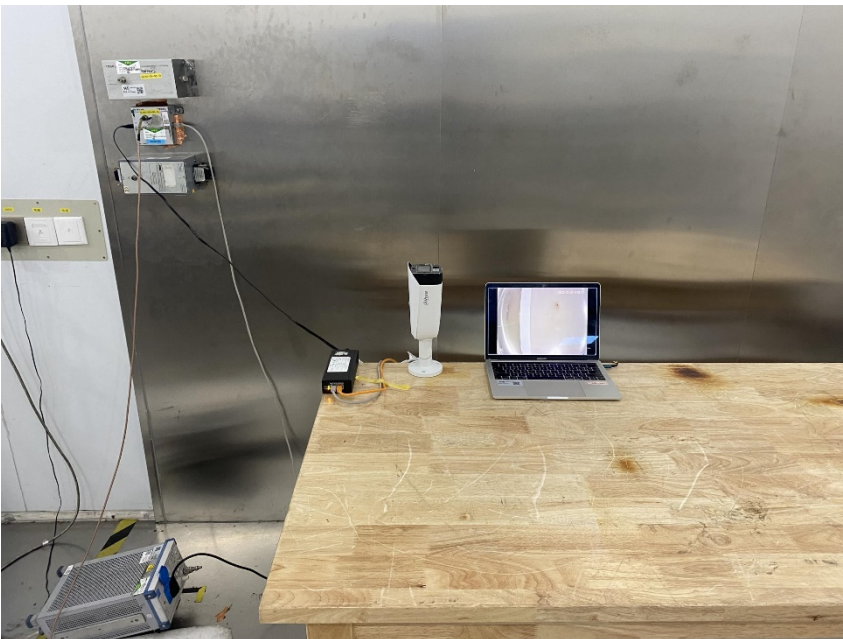
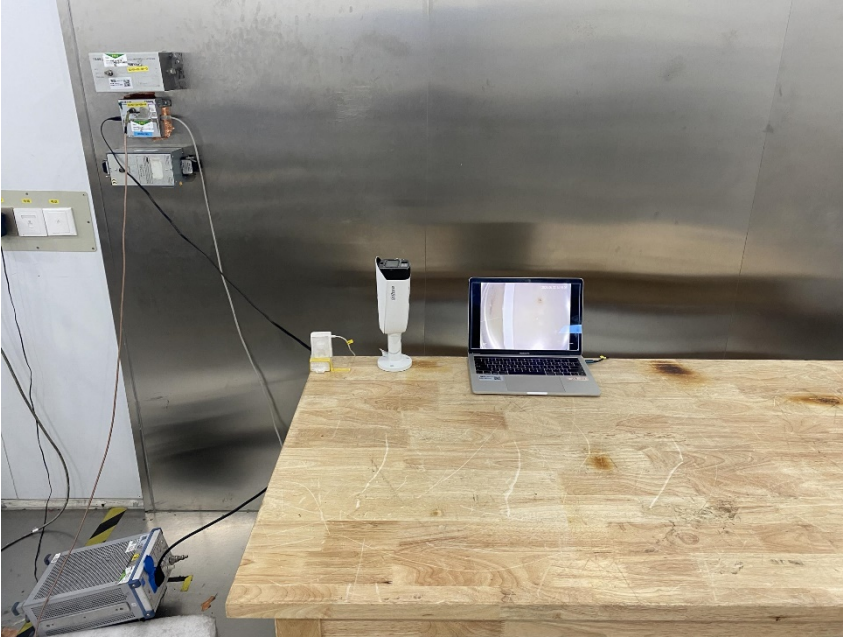

## Radiated Emissions (30MHz-1GHz)



## Radiated Emissions (Above 1GHz)

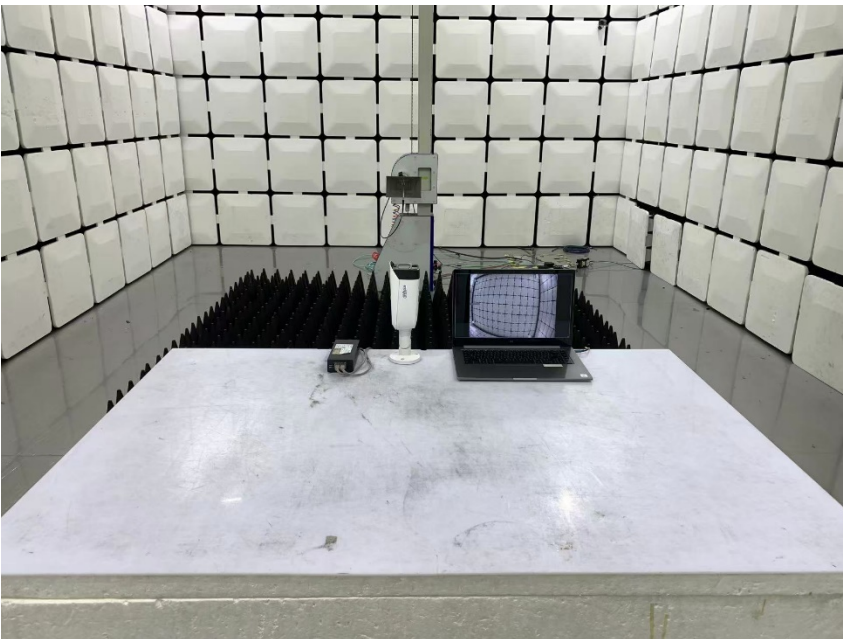
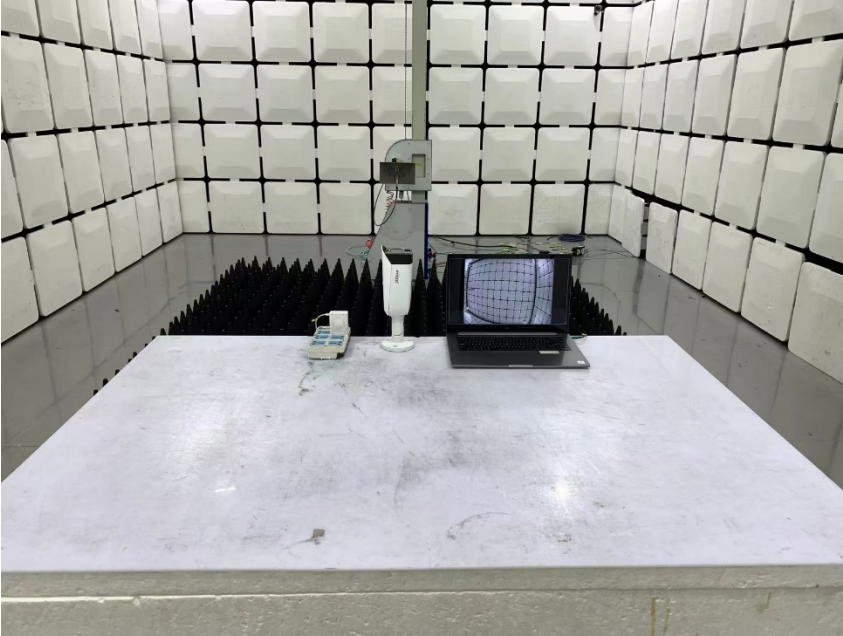

## Voltage Fluctuations and Flicker



## Harmonic Current Emission



## Electrostatic Discharge

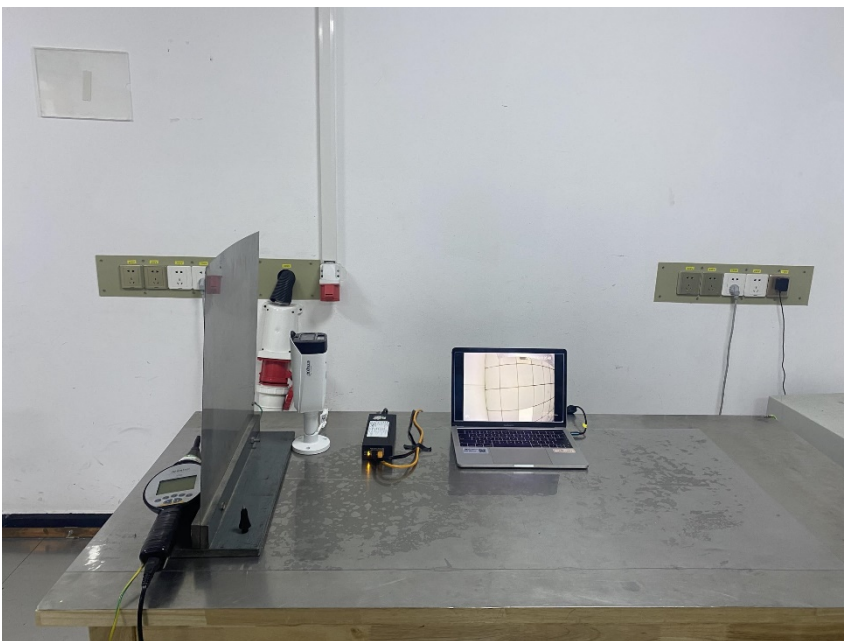

## Radiated Immunity(80MHz-2.7GHz)

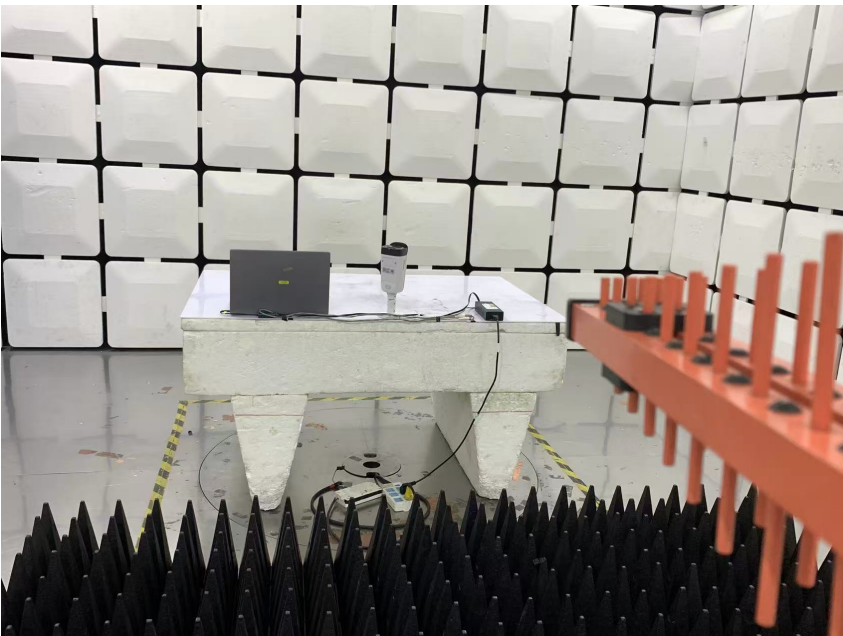
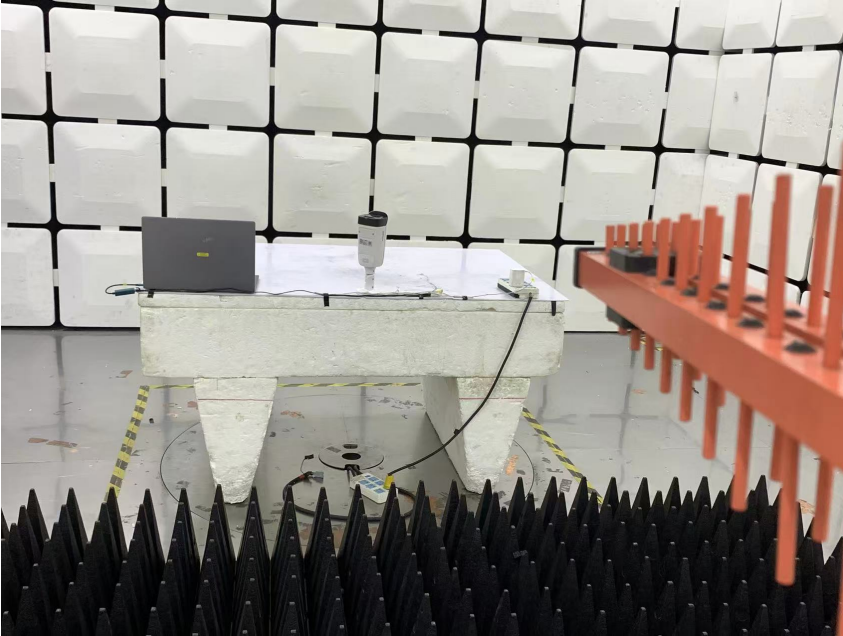

## Electrical Fast Transients & Burst at AC Power Port

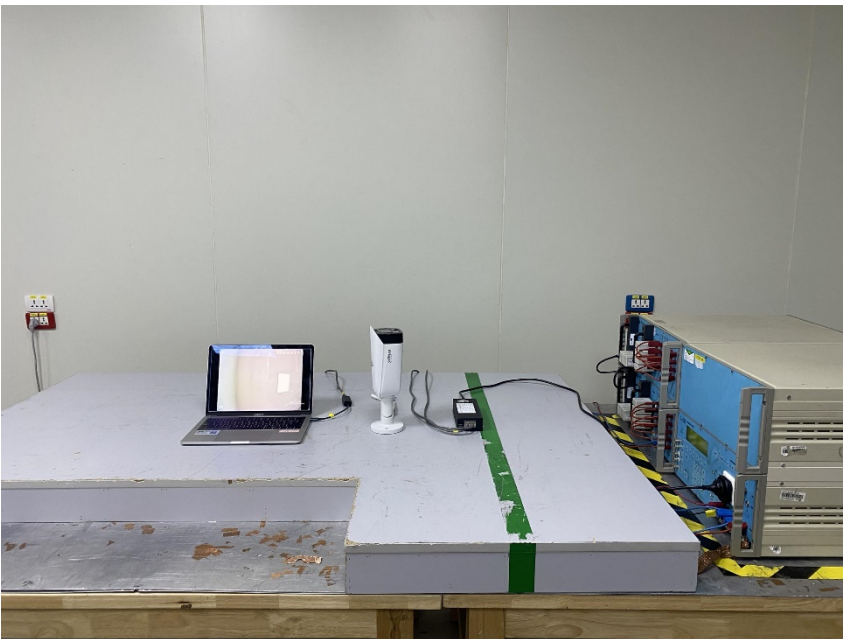

## Electrical Fast Transients & Burst at Signal Port



## Surge at AC Power Port

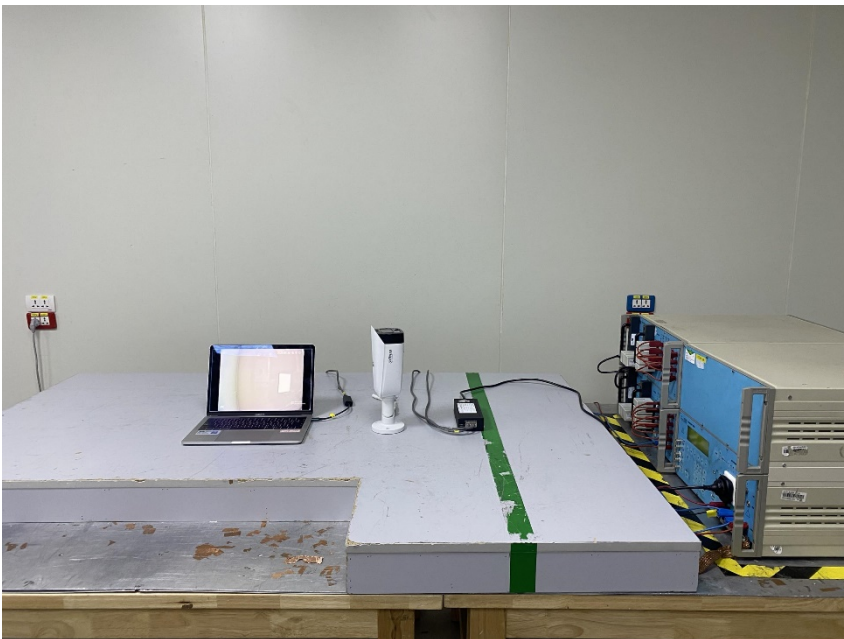

## Surge at Signal Port



## Conducted Immunity at Power Port (150kHz-100MHz)

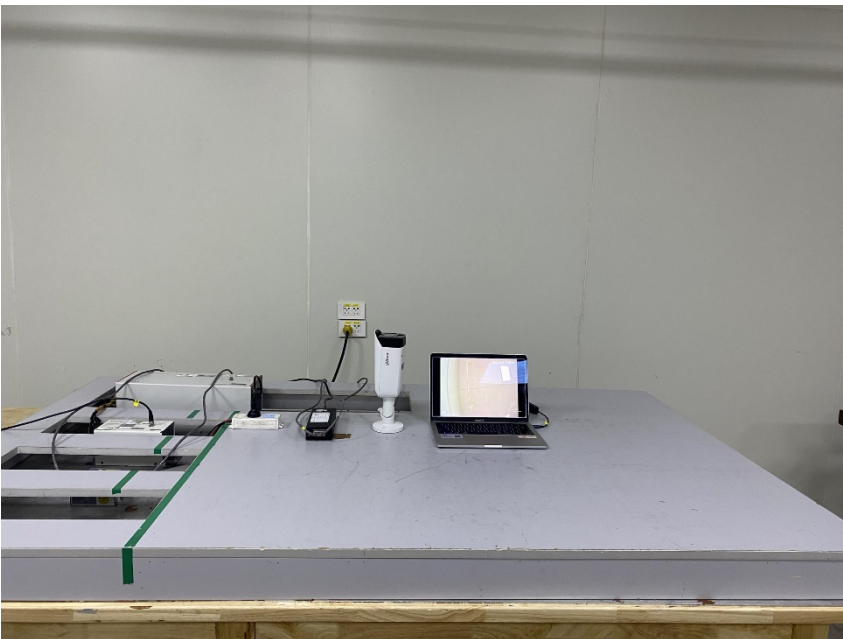

## Conducted Immunity at Signal Port (150kHz-100MHz)

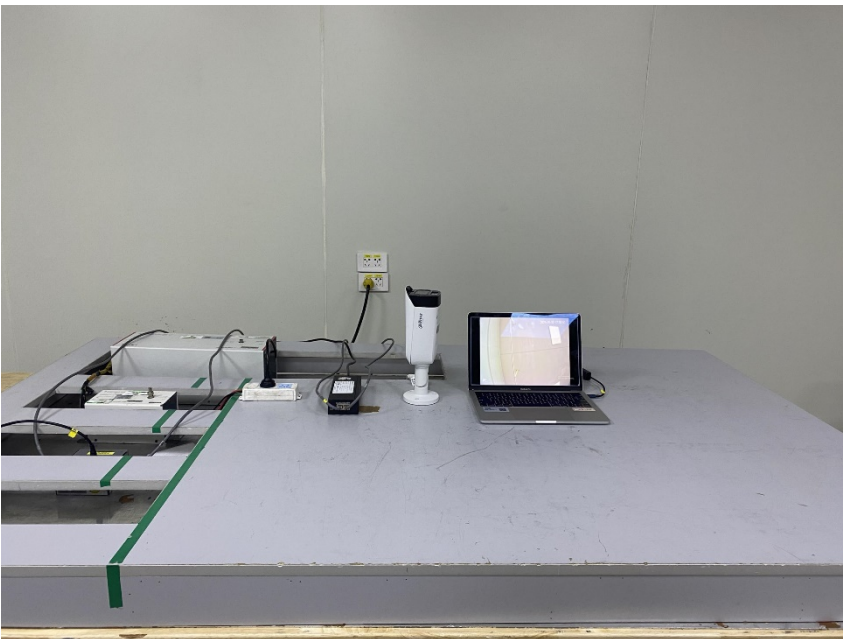

## Mains Supply Voltage Variations

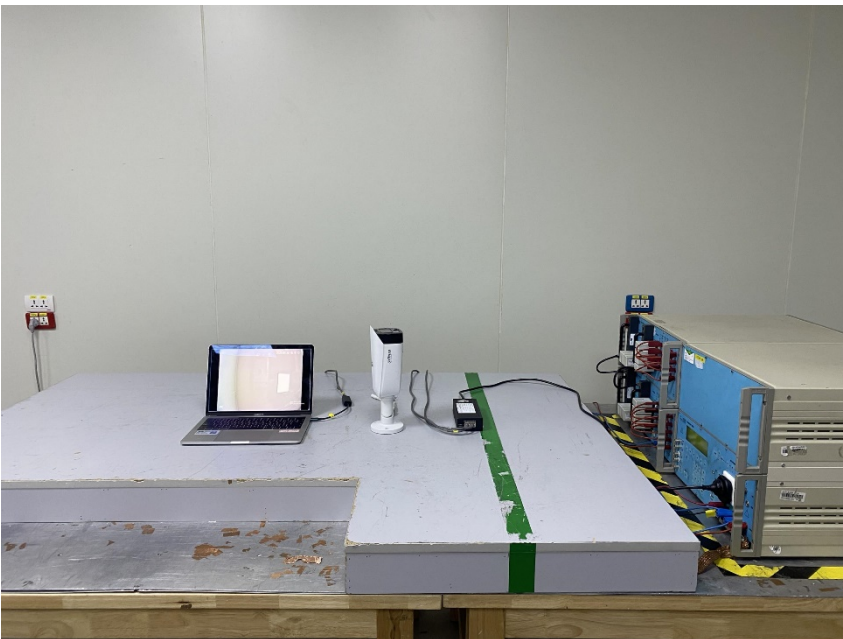

## Voltage Dips and Interruptions

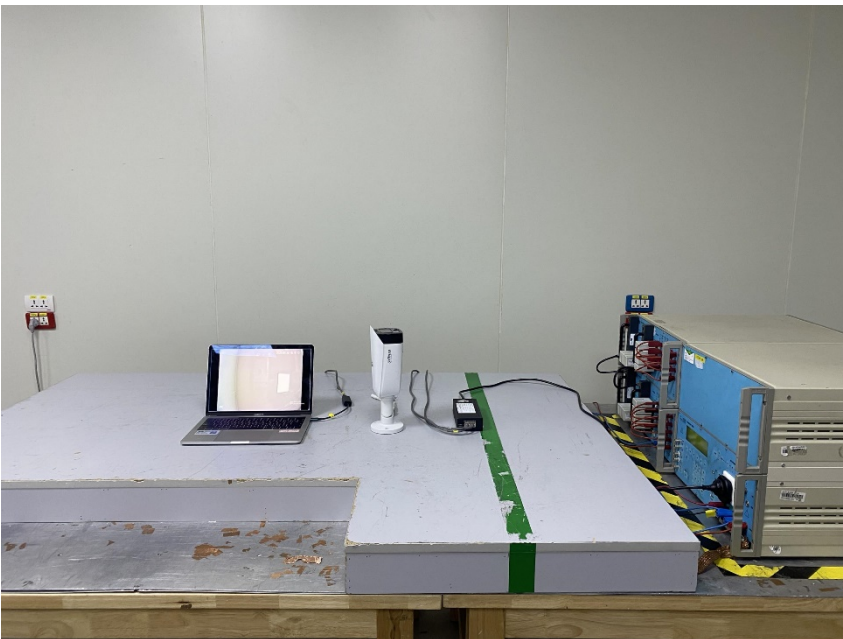

## Electrostatic Discharge



**Radiated Immunity (80MHz-  
1GHz,1800MHz,2600MHz,3500MHz,5000MHz)**

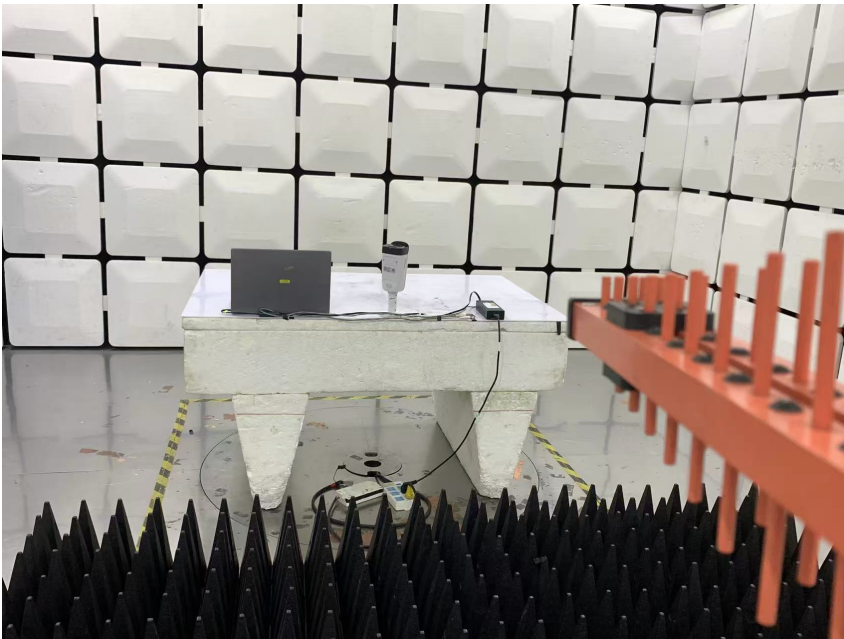
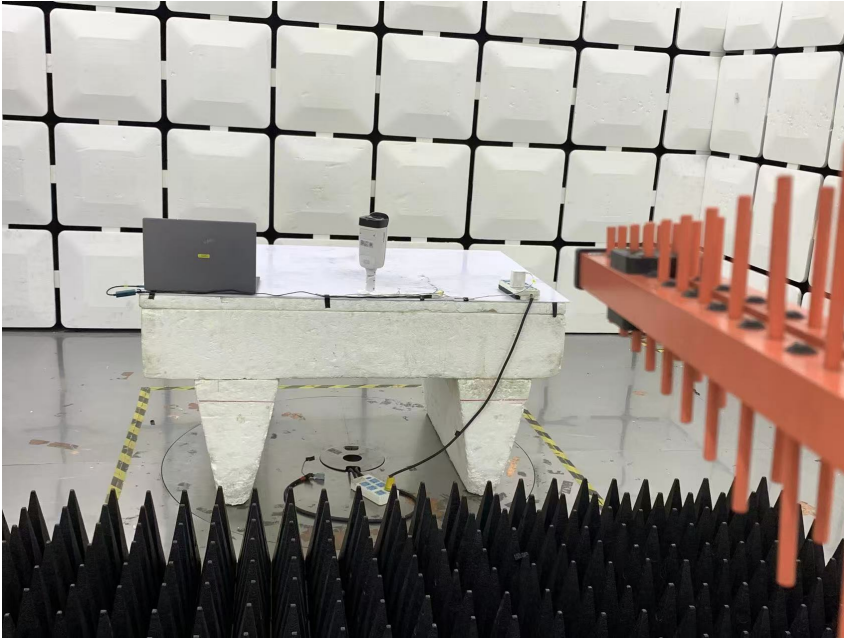

## Electrical Fast Transients & Burst at AC Power Port

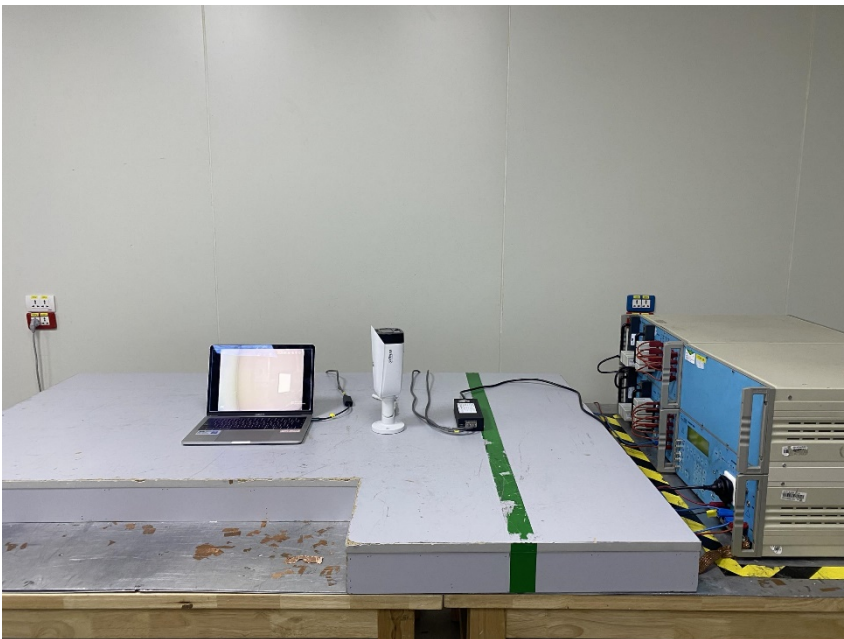

## Electrical Fast Transients & Burst at Signal Port



## Surge at AC Power Port

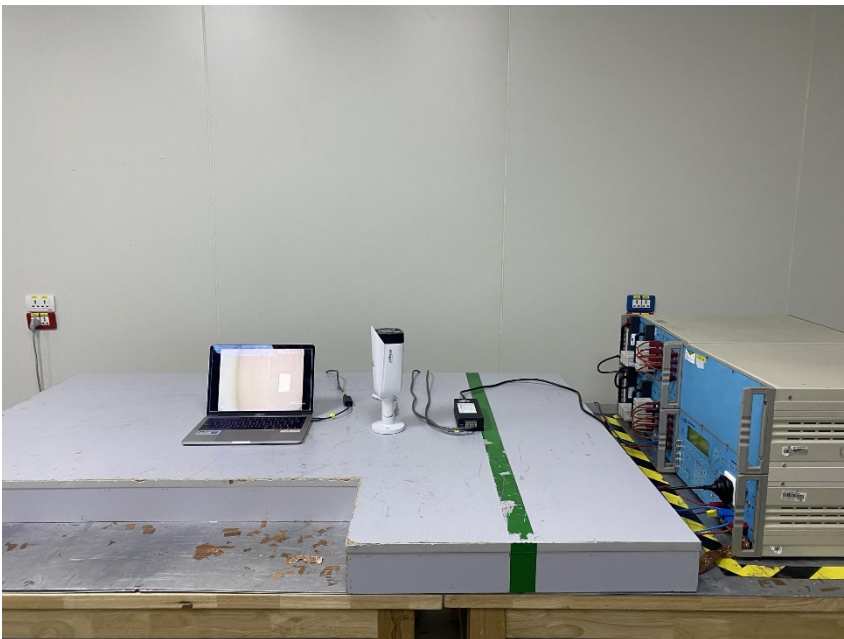

## Surge at Signal Port

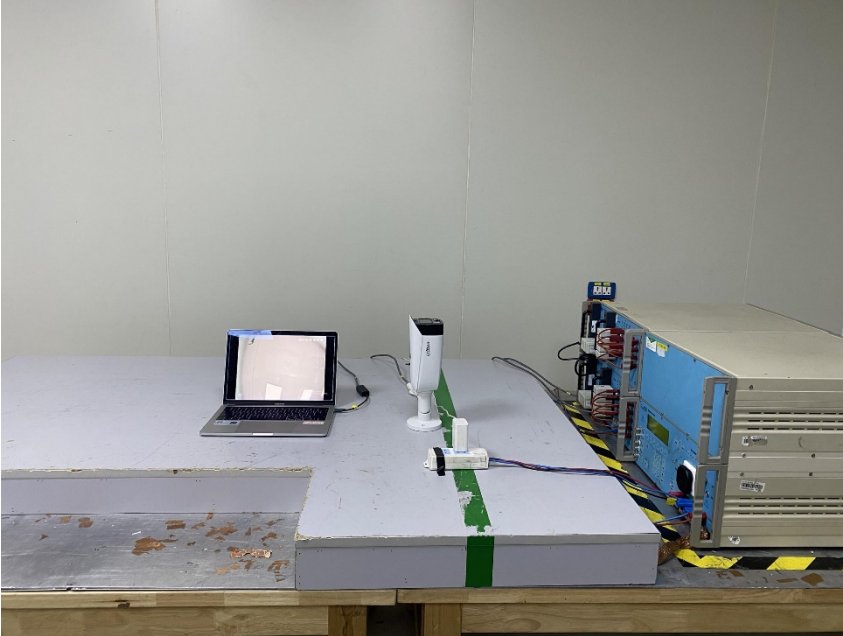

## Conducted Immunity at AC Power Port (150kHz-80MHz)

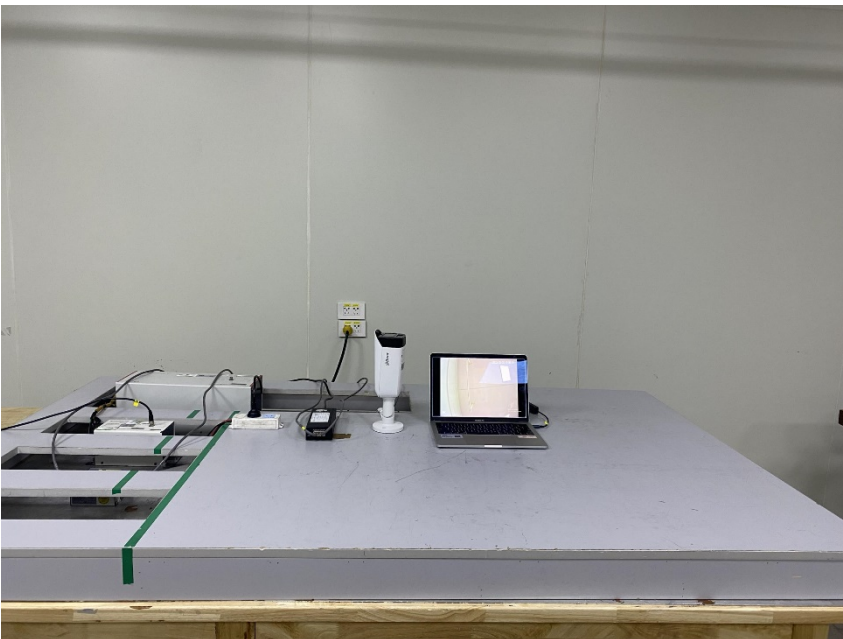

## Conducted Immunity at Signal Port (150kHz-80MHz)

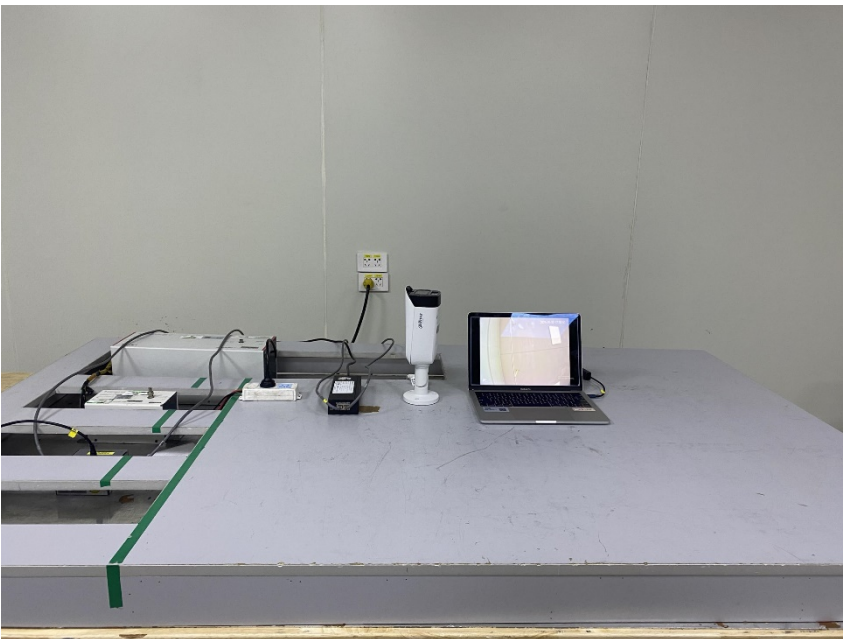

## Power Frequency Magnetic Field

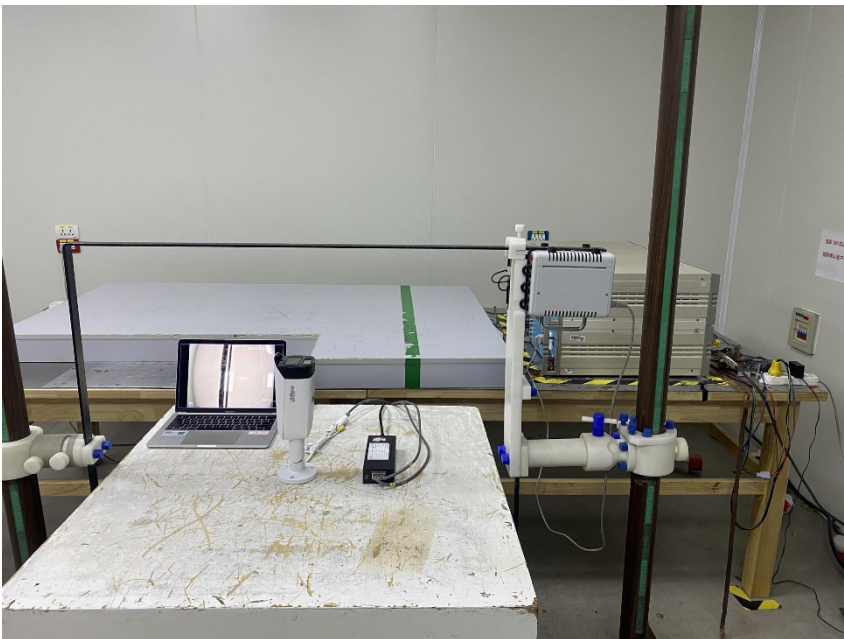
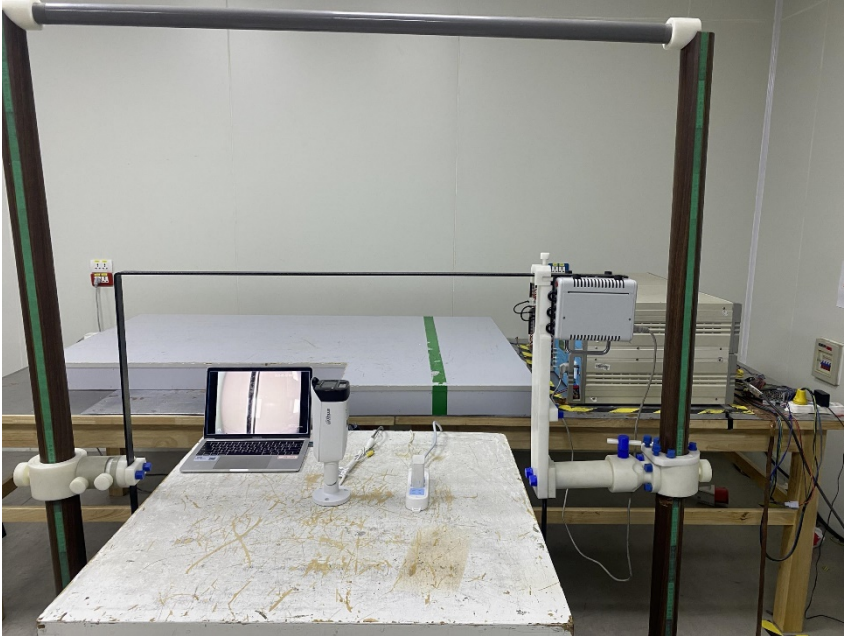

## 9 EUT Constructional Details (EUT Photos)



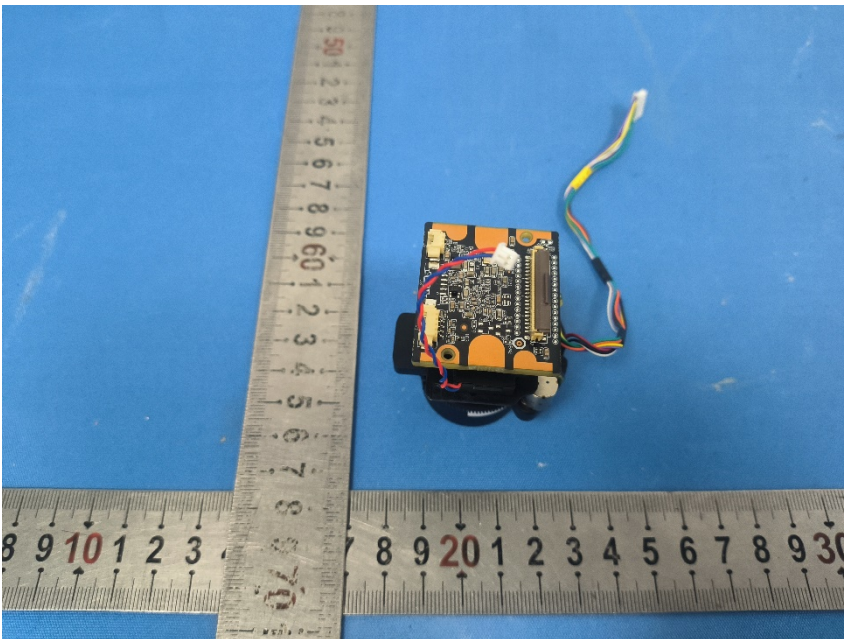
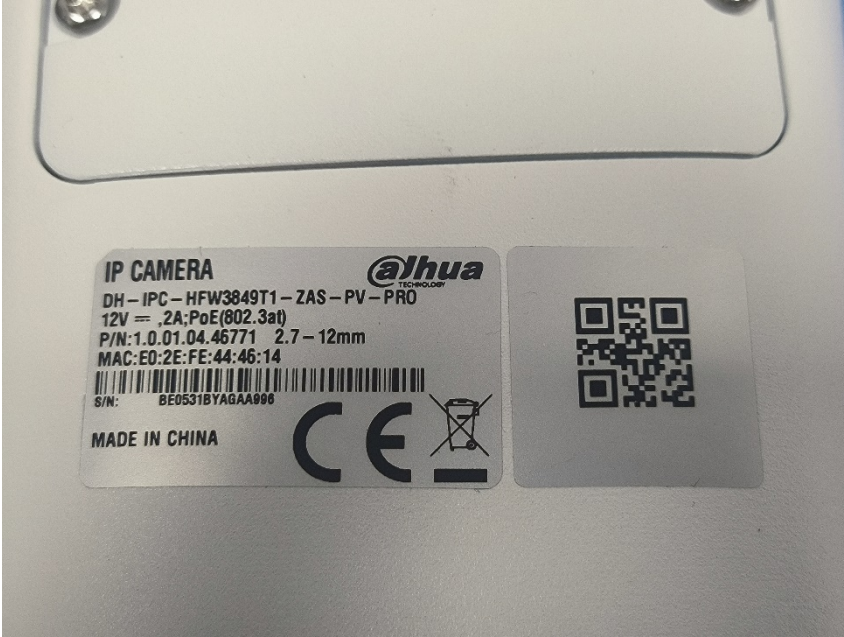

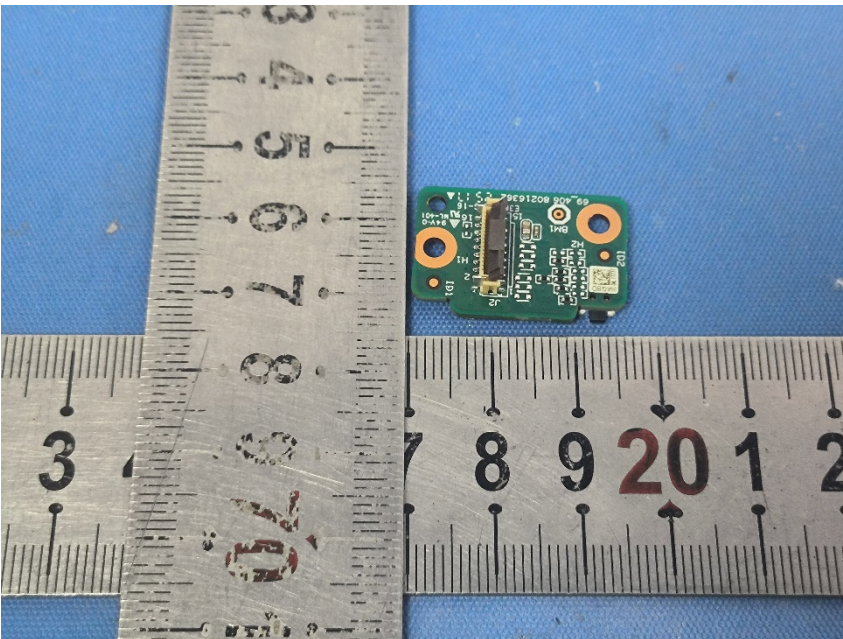
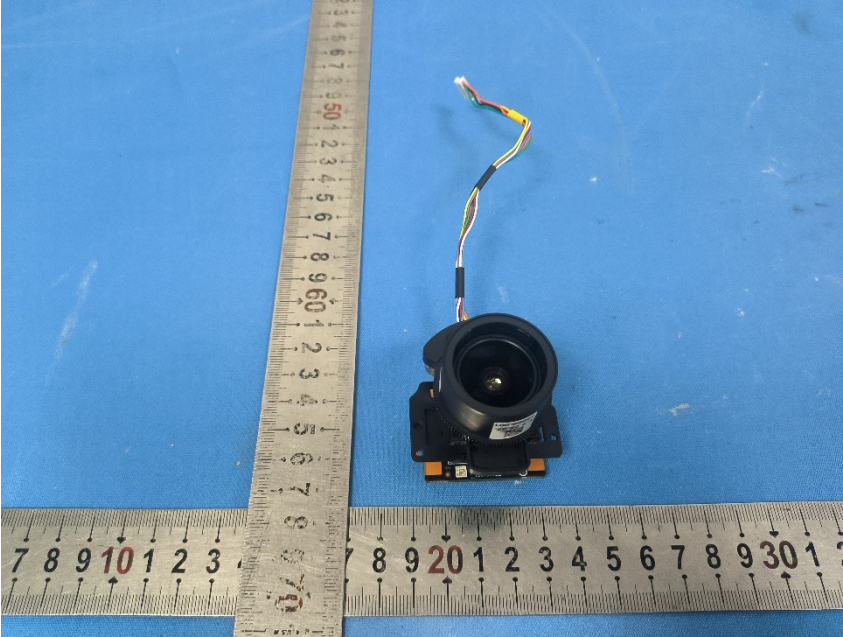

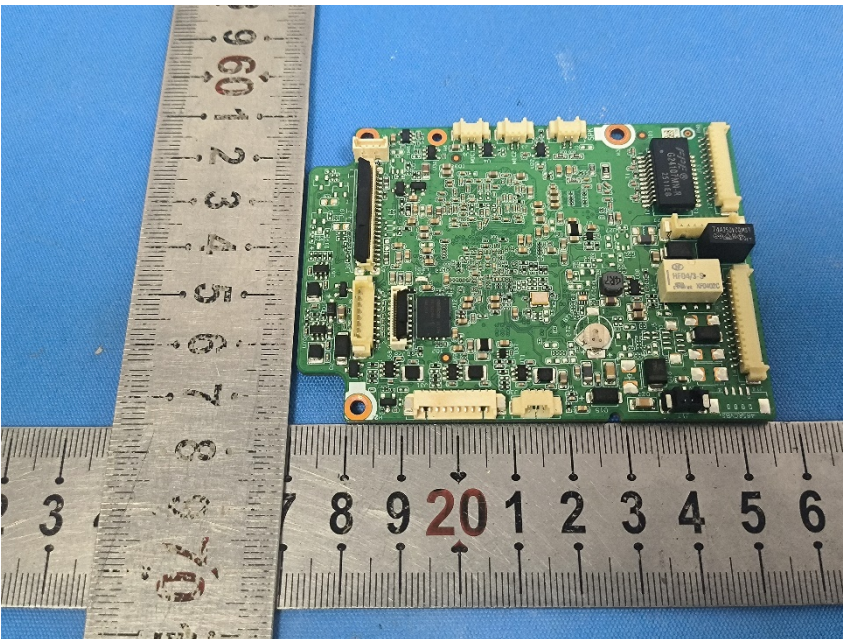
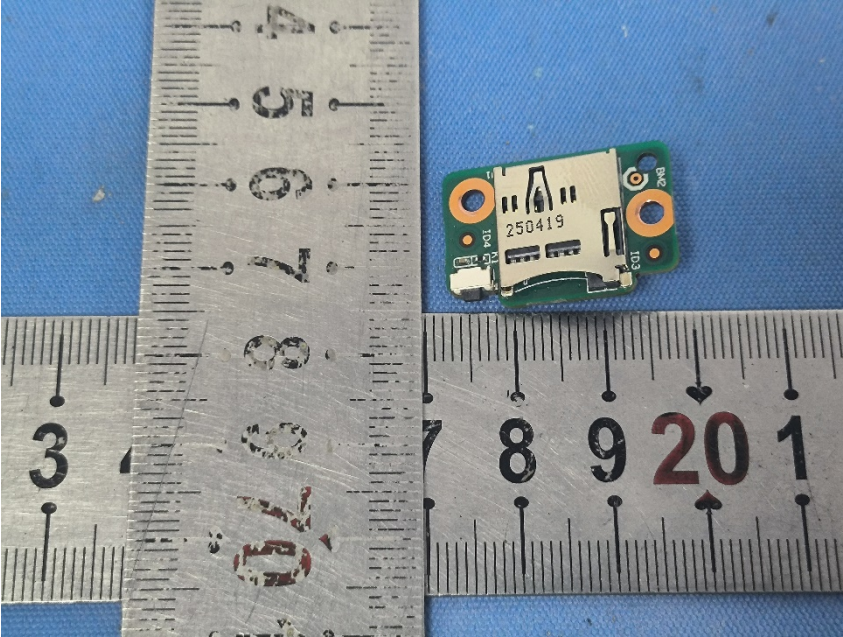

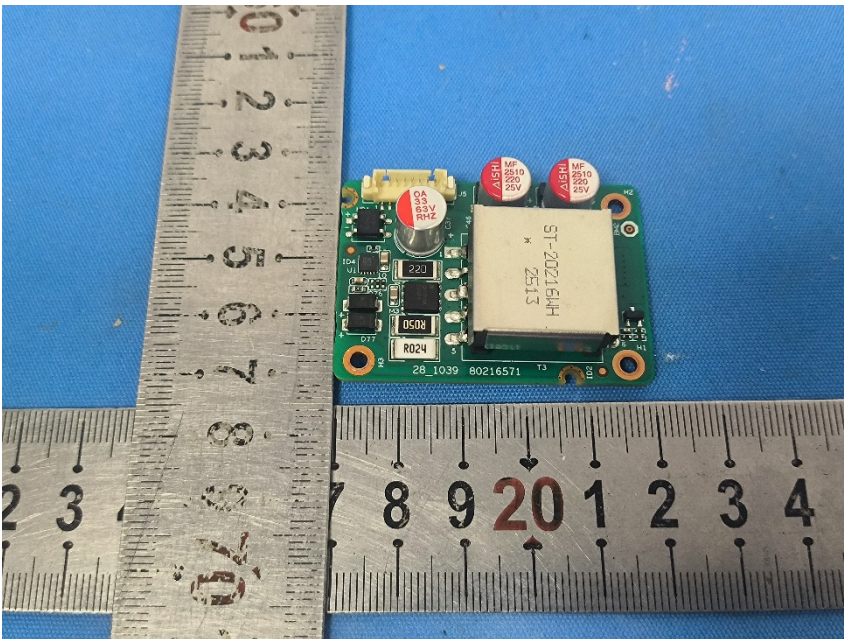
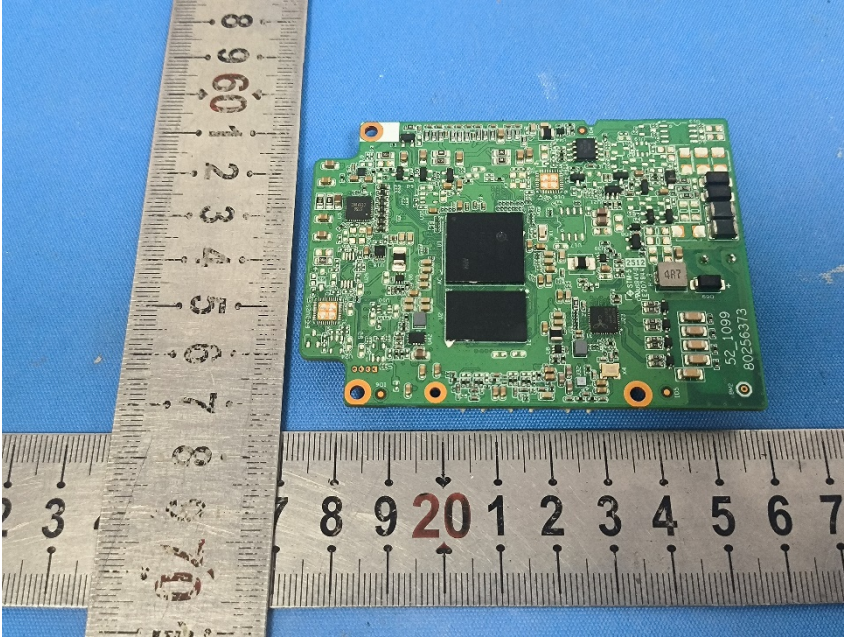

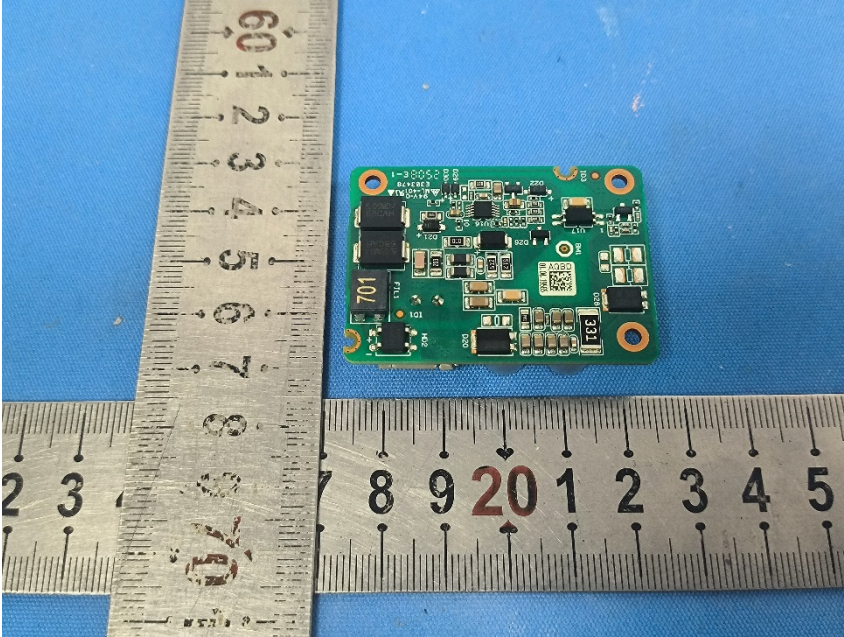

- End of the Report -