



NETWORK CAMERA

Quick Guide

SLA-T2480WDA/SLA-T2480WA
SLA-F2480WDA/SLA-F2480WA



Warranty

Please check "Product warranty information" from our website.
<https://www.hanwhavision.com/en/support/warranty/>

Videos processed by surveillance equipment cannot be accessed arbitrarily by the manufacturer.



Hanwha Vision cares for the environment at all product manufacturing stages, and is taking measures to provide customers with more environmentally friendly products.

The Eco mark represents Hanwha Vision's devotion to creating environmentally friendly products, and indicates that the product satisfies the EU RoHS Directive.



Correct Disposal of This Product (Waste Electrical & Electronic Equipment)

(Applicable in the European Union and other European countries with separate collection systems)

This marking on the product, accessories or literature indicates that the product and its electronic accessories (e.g. charger, headset, USB cable) should not be disposed of with other household waste at the end of their working life. To prevent possible harm to the environment or human health from uncontrolled waste disposal, please separate these items from other types of waste and recycle them responsibly to promote the sustainable reuse of material resources.

Household users should contact either the retailer where they purchased this product, or their local government office, for details of where and how they can take these items for environmentally safe recycling. Business users should contact their supplier and check the terms and conditions of the purchase contract. This product and its electronic accessories should not be mixed with other commercial wastes for disposal.



Correct disposal of batteries in this product

(Applicable in the European Union and other European countries with separate battery return systems.)

This marking on the battery, manual or packaging indicates that the batteries in this product should not be disposed of with other household waste at the end of their working life. Where marked, the chemical symbols Hg, Cd or Pb indicate that the battery contains mercury, cadmium or lead above the reference levels in EC Directive 2006/66. If batteries are not properly disposed of, these substances can cause harm to human health or the environment.

To protect natural resources and to promote material reuse, please separate batteries from other types of waste and recycle them through your local, free battery return system.

1. Read these instructions.
2. Keep these instructions.
3. Heed all warnings.
4. Follow all instructions.
5. Do not use this apparatus near water.
6. Clean the contaminated area on the product surface with a soft, dry cloth or a damp cloth.
(Do not use a detergent or cosmetic products that contain alcohol, solvents or surfactants or oil constituents as they may deform or cause damage to the product.)
7. Do not block any ventilation openings, Install in accordance with the manufacturer's instructions.
8. Do not install near any heat sources such as radiators, heat registers, stoves, or other apparatus (including amplifiers) that produce heat.
9. Do not defeat the safety purpose of the polarized or grounding-type plug. A polarized plug has two blades with one wider than the other. A grounding type plug has two blades and a third grounding prong. The wide blade or the third prong are provided for your safety. If the provided plug does not fit into your outlet, consult an electrician for replacement of the obsolete outlet.
10. Protect the power cord from being walked on or pinched particularly at plugs, convenience receptacles, and the point where they exit from the apparatus.
11. Only use attachments/ accessories specified by the manufacturer.
12. Use only with the cart, stand, tripod, bracket, or table specified by the manufacturer, or sold with the apparatus. When a cart is used, use caution when moving the cart/apparatus combination to avoid injury from tip-over.



13. Unplug this apparatus during lightning storms or when unused for long periods of time.
14. Refer all servicing to qualified service personnel. Servicing is required when the apparatus has been damaged in any way, such as power-supply cord or plug is damaged, liquid has been spilled or objects have fallen into the apparatus, the apparatus has been exposed to rain or moisture, does not operate normally, or has been dropped.
15. This product is intended to be supplied by a UL Listed Power Supply Unit marked "Class 2" or "LPS" or "PS2" and rated from 5 Vdc, 0.25 A.



Any changes or modifications in construction of this device which are not expressly approved by the party responsible for compliance could void the user's authority to operate the equipment.

This device complies with part 15 of the FCC Rules. Operation is subject to the following two conditions: (1) This device may not cause harmful interference, and (2) this device must accept any interference received, including interference that may cause undesired operation.

This equipment has been tested and found to comply with the limits for a Class A digital device, pursuant to part 15 of the FCC Rules. These limits are designed to provide reasonable protection against harmful interference when the equipment is operated in a commercial environment. This equipment generates, uses, and can radiate radio frequency energy and, if not installed and used in accordance with the instruction manual, may cause harmful interference to radio communications. Operation of this equipment in a residential area is likely to cause harmful interference in which case the user will be required to correct the interference at his own expense.

SAFETY INFORMATION

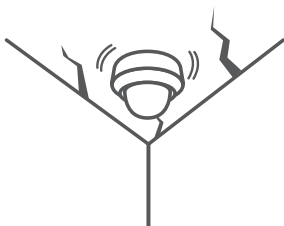

COMPONENT

As for each sales country, accessories are not the same.

- SLA-T2480WDA/SLA-F2480WDA

* The shape of the lens module may differ depending on the model names.

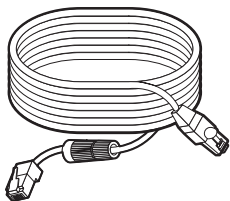
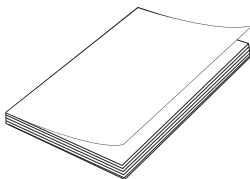
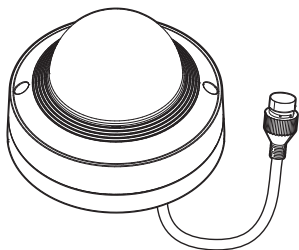

INSTALLATION

1

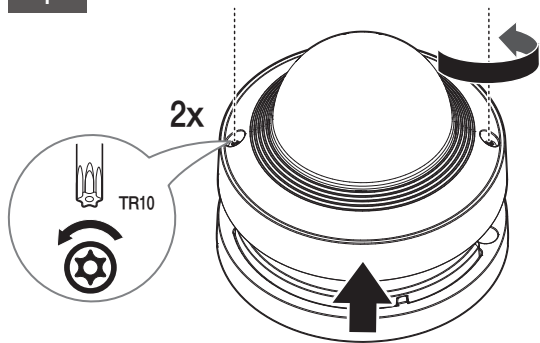

2

- Directly installing on wall/ceiling

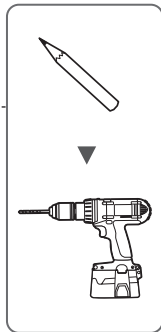
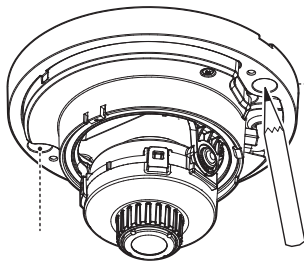

INSTALLATION

3

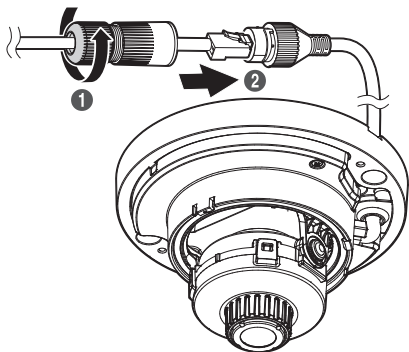

4

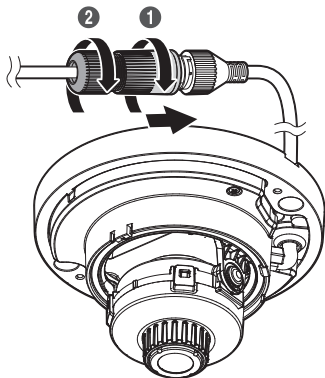

INSTALLATION

5

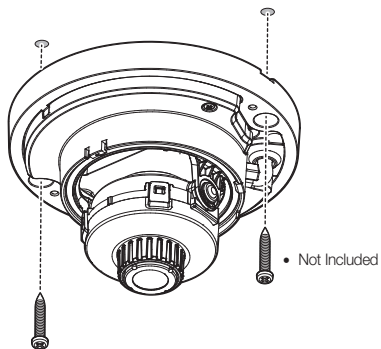

INSTALLATION



6

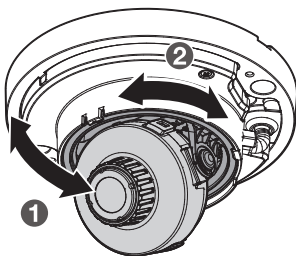

INSTALLATION

7

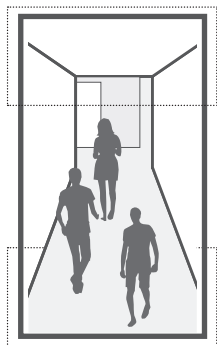
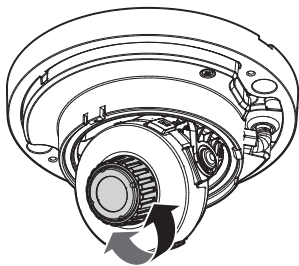

INSTALLATION

8

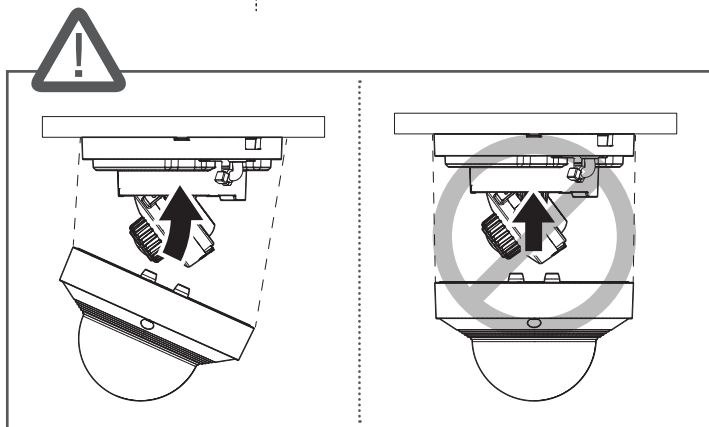
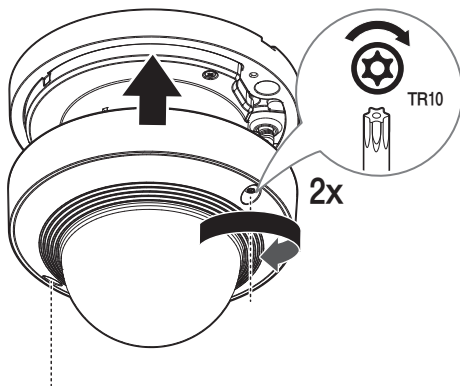

COMPONENT

As for each sales country, accessories are not the same.

- SLA-T2480WA/SLA-F2480WA

* The shape of the lens module may differ depending on the model names.

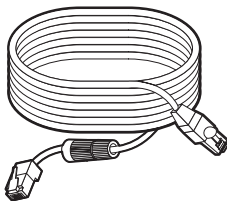
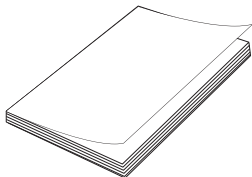
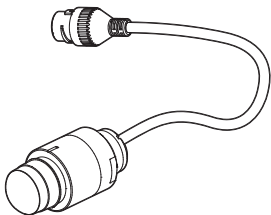

INSTALLATION

1

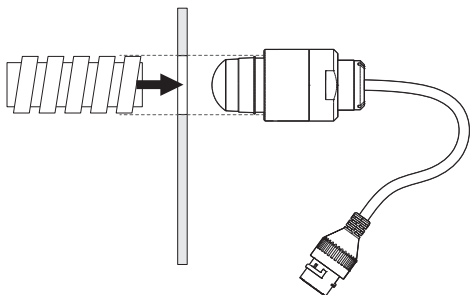

2

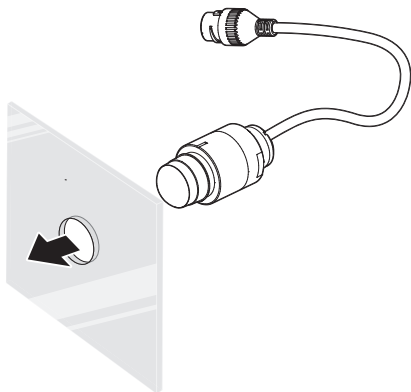

INSTALLATION

3

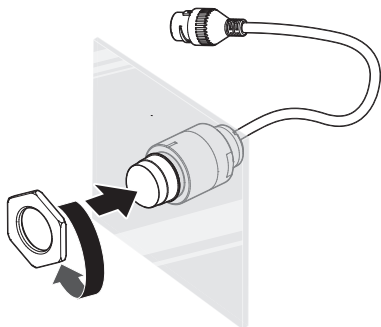

4

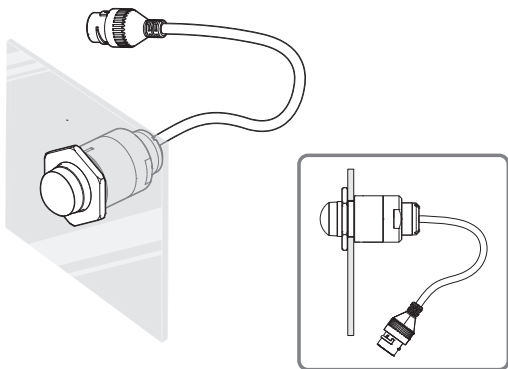

INSTALLATION

5

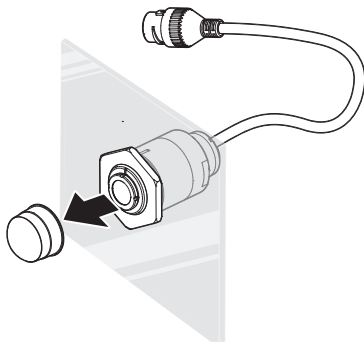

6

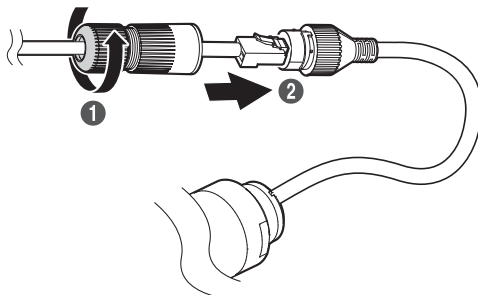

INSTALLATION

7

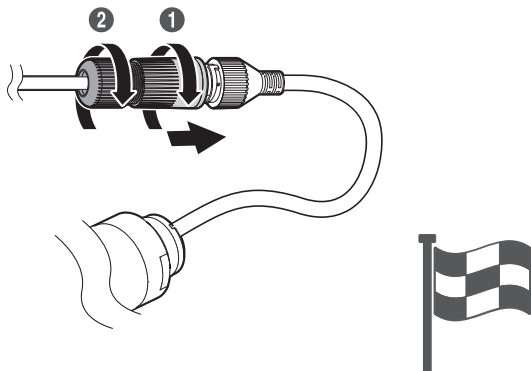

ADJUST THE LENGTH OF THE CABLE FOR CONNECTING THE LENS MODULE

1

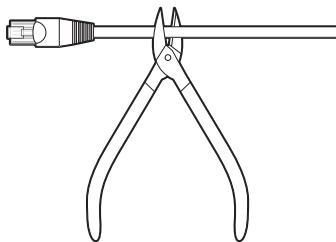

2

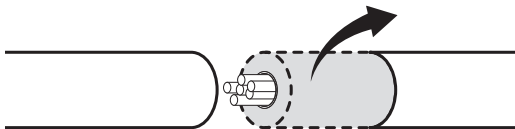

ADJUST THE LENGTH OF THE CABLE FOR CONNECTING THE LENS MODULE

3

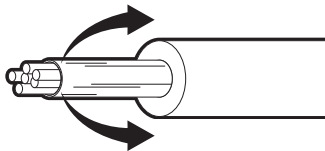

4

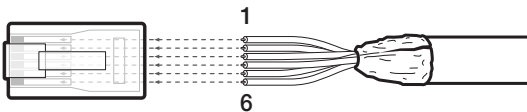

| Number | Color |
|--------|--------|
| 1 | Black |
| 2 | Red |
| 3 | Bule |
| 4 | Orange |
| 5 | White |
| 6 | Green |

ADJUST THE LENGTH OF THE CABLE FOR CONNECTING THE LENS MODULE

5

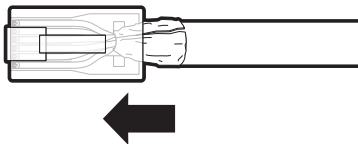

6

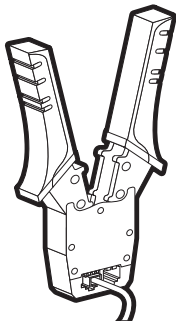

서비스 요청하시기 전에 꼭 알아 두세요

다음과 같은 사항에 대하여 서비스 요청 시 유상서비스로 처리될 수 있습니다.

[1] 고객 주의사항

- 보안 시스템 및 제품의 이상 유무를 정기적으로(매일) 점검하여 사용하시기 바랍니다.
- 본 제품은 감시 보조 장비로 도난(재산 피해), 화재, 천재지변 등으로 인해 발생된 물적/인적 피해에 대해서는 제조사에서 책임지지 않습니다.
- A/S는 당사 해당 제품(단품)에 대해서만 가능합니다.
설치 문제로 인한 불량은 설치 전문 업체 및 유지 보수업체를 통해 처리하셔야 합니다.
- 제품 사용 설명서에 포함되지 않는 기능이나, 타사 쇼핑몰 등에서 잘못 기재된 기능은 당사에서 책임지지 않습니다.
- 제품에 저장된 중요한 데이터는 서비스를 받는 동안 손실될 수 있습니다. 따라서, 서비스 요청 전 반드시 백업해 두시기 바랍니다. 수리과정에서 손실될 경우 당사에서 책임지지 않습니다.

[2] 제품 사용 설명서로 서비스 요청한 경우

- 사용 환경에 따른 신호 점검, 전원 점검, 네트워크 환경 문제 등의 서비스 요청 시
- 제품과 관련된 타기기의 설치, 설명 요청 시

[3] 단순 분해조립, 간단조정, S/W 업그레이드 등으로 서비스 요청한 경우

- 제품 안에 이물질이 투입되어 문제가 발생하는 경우
- 제품 간단 조정이나 분해하지 않고 처리하는 경우
- 제품 고장 요인이 아닌 S/W 업그레이드 요청 시

[4] 그 밖의 경우

- 제품에서 사용되는 소모품(기록 매체 등)의 관리 소홀로 인한 고장이나 사용 설명 서비스 요청 시
(소모품 문제에 대한 사용설명 및 서비스 요청은 해당 업체에 문의하여 주십시오)
- 품질이 좋지 않은 기록 매체 사용에 따른 고장이나 사용 설명 서비스 요청 시
- 제품이 비정상적인 환경에서 사용하거나 설치되어 문제가 발생한 경우

※ 상기와 같은 유형의 서비스를 받으실 경우에는 소정의 수수료가 부과될 수 있으므로, 서비스 신청전 전문상담원 (☎1588-5772)을 통하여 보다 양질의 서비스를 받으시길 권장 드립니다.

품질보증서

| | | |
|---------|--|-------------------------|
| 제 품 명 | 네트워크 카메라 | 보증 기간 |
| 모 델 명 | SLA-T2480WDA/SLA-T2480WA SLA-F2480WDA/SLA-F2480WA | 구 입 후 3년 (소모품 제외) |
| 구 입 일 자 | 년 월 일 | |
| 보 증 기 간 | 년 월 일 까지 | |

| | | |
|------------|-----|--|
| 고객 주소 | 성 명 | |
| | 연락처 | |
| 판매점 주소(상호) | 성 명 | |
| | 연락처 | |

※ 제품 판매 시 공란의 내용을 필히 기입하여 주십시오.

◀ 서비스를 받으실 때 ▶

제품 고장으로 판단되더라도 서비스를 요청하기 전에 반드시 사용설명서를 한 번 더 읽어 주십시오.
사용방법을 알지 못해서 고장으로 판단하실 수 있으므로 사용설명서의 취급법과 주의사항 등을 보시면 간단히 해결되는 경우가 있습니다.

서비스를 요청하시는 방법은?

요청하실 때는 고장상태를 정확히 알려 주십시오.

이때 보증서를 함께 제시하시면 보증서에 기재된 내용에 따라 유상, 무상수리의 구분이 됩니다.

한화비전(주)

경기도 성남시 분당구 판교로 319번길 6 (삼평동 701)

영 업 TEL 070-7147-8771~9 A/S 및 기술문의 1588-5772

부산영업소 TEL 051-796-3216

대구영업소 TEL 053-742-3098

광주영업소 TEL 062-941-9559

대전영업소 TEL 042-489-9840

아래 사항에 따른 고장은 보증에서 제외되며, 수리 불가 혹은 유상 처리 될 수 있습니다.

- 1) 설치자 과실, 사용자 취급 부주의에 의한 고장
- 2) 정격 전원 외의 전원 연결 시
- 3) 사용자 임의로 분해, 수리한 경우
- 4) 자연재해에 의한 고장 (낙뢰, 지진, 화재, 홍수, 해일 등)
- 5) 소모품 교체 및 추가 시(HDD/SSD, SD카드, 아답터, FAN 등)



EAC

Подлежит использованию по назначению
в нормальных условиях
Срок службы : 7 лет.

Türkiye Distribütörü

EDS Elektronik Destek Sanayi ve Ticaret Ltd. Şti.

Meclis Mah. Teraziler Cad. Hayran Sk. (Eskisi Kılıç Sk.) No: 4 Sancaktepe / İstanbul / Türkiye
Tel +90.216.313.25.15

ENTES ELEKTRONİK CİHAZLAR İMALAT VE TİC. A.Ş.

Dudullu Org.San.Bölg. 1. Cad. No:23 34776 Ümraniye / İstanbul / Türkiye
Tel +90.216.313.01.10

TEKNOMAKS TEKNOLOJİ / TEKNOMAKS BİLİSİM

MERDİVENKÖY MAH.DİKYOL SOK. BUSINESS İSTANBUL No:2, Kat:7, D:B67, 34732 Kadıköy / İstanbul / Türkiye
Tel +90.212.217.54.22

Cihazın Ticaret Bakanlığınca önerilen ortalama ömrü

Cihazın EEE yönetmeliklerine uygun olduğuna benzer beyan

