

# **KAMERA SIECIOWA**

## Skrócona Instrukcja Obsługi

QNV-C8013R/QNV-C8023R  
QND-C8013R/QND-C8023R  
QNO-C8013R/QNO-C8023R



## Important

Please check 'Manuals' from our website, before connecting to the Supply,  
<https://www.hanwhavision.com/en/download-data/>

## Warranty

Please check "Product warranty information" from our website.  
<https://www.hanwhavision.com/en/support/warranty/>

We recommend to use the officially compatible VMS version or latest Hanwha NVR version when integrating with VMS or Hanwha NVR.



Hanwha Vision cares for the environment at all product manufacturing stages, and is taking measures to provide customers with more environmentally friendly products.

The Eco mark represents Hanwha Vision's devotion to creating environmentally friendly products, and indicates that the product satisfies the EU RoHS Directive.



### Correct Disposal of This Product (Waste Electrical & Electronic Equipment)

(Applicable in the European Union and other European countries with separate collection systems)

This marking on the product, accessories or literature indicates that the product and its electronic accessories (e.g. charger, headset, USB cable) should not be disposed of with other household waste at the end of their working life. To prevent possible harm to the environment or human health from uncontrolled waste disposal, please separate these items from other types of waste and recycle them responsibly to promote the sustainable reuse of material resources.

Household users should contact either the retailer where they purchased this product, or their local government office, for details of where and how they can take these items for environmentally safe recycling.

Business users should contact their supplier and check the terms and conditions of the purchase contract.

This product and its electronic accessories should not be mixed with other commercial wastes for disposal.



### Correct disposal of batteries in this product

(Applicable in the European Union and other European countries with separate battery return systems.)

This marking on the battery, manual or packaging indicates that the batteries in this product should not be disposed of with other household waste at the end of their working life. Where marked, the chemical symbols Hg, Cd or Pb indicate that the battery contains mercury, cadmium or lead above the reference levels in EC Directive 2006/66. If batteries are not properly disposed of, these substances can cause harm to human health or the environment.

To protect natural resources and to promote material reuse, please separate batteries from other types of waste and recycle them through your local, free battery return system.

# SAFETY INFORMATION

---



**Wandaloodporna kamera  
kopiłkowa**

QNV-C8013R/QNV-C8023R

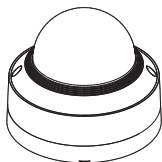

**Kamera kopiłkowa**

QND-C8013R/QND-C8023R

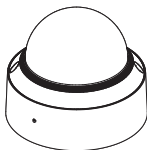

**Kamera typu bullet**

QNO-C8013R/QNO-C8023R

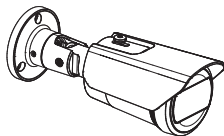



## COMPONENT

---

Akcesoria nie są identyczne i zależą od kraju sprzedaży.

- QNV-C8013R/QNV-C8023R

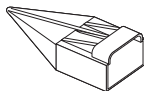
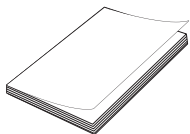
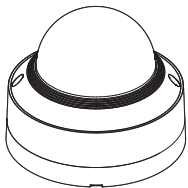

### **I** Opcje (Kupowane oddz)

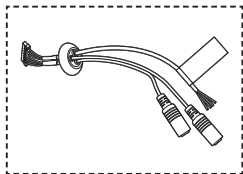

SPP-C7400

# INSTALLATION

1

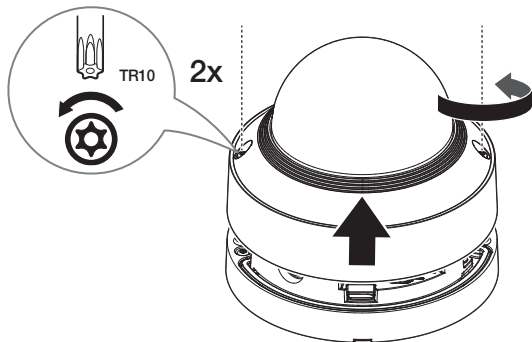

2

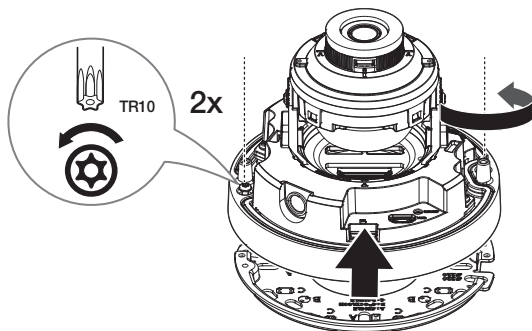

## INSTALLATION

3

- Kupowane oddz.: Karta Micro SD

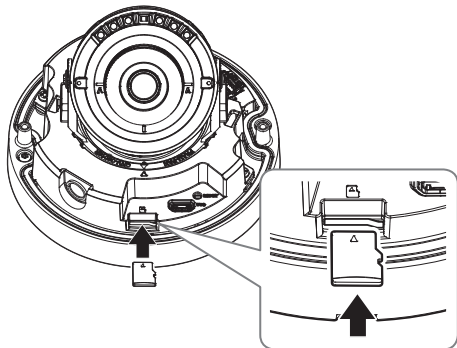

4

- Instalacja bezpośrednio na ścianie/suficie

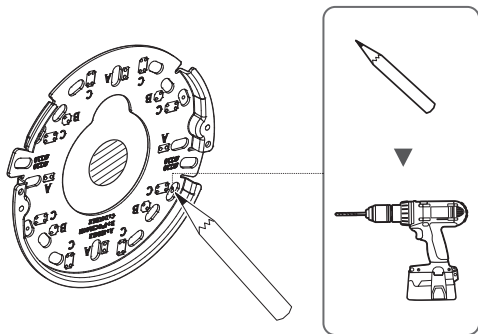

## INSTALLATION

5

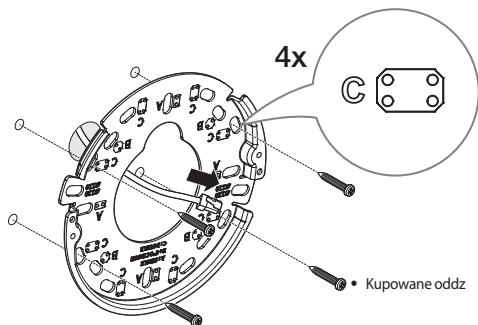

6

- Przy podłączaniu kabla z boku

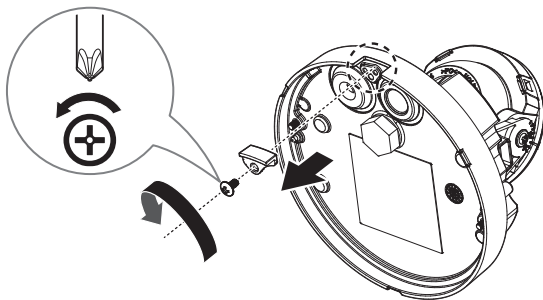

## INSTALLATION

7-1

- Instalacja kabla sieciowego (IP66)

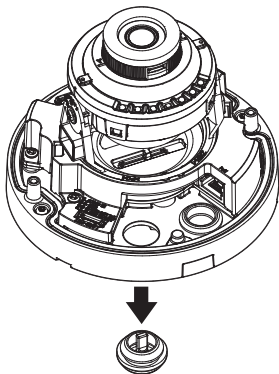

7-2

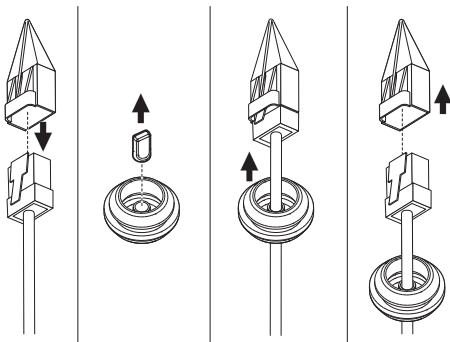

## INSTALLATION

7-3

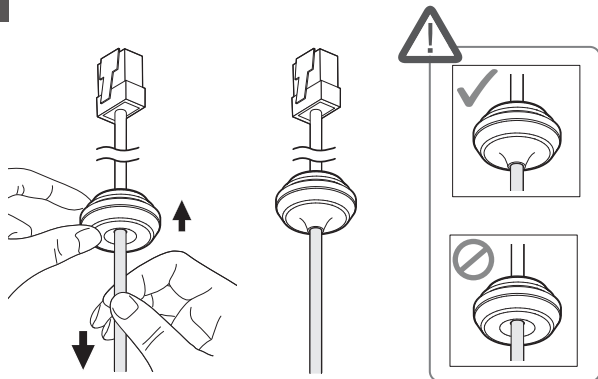

7-4

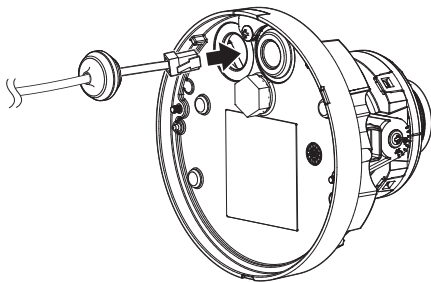

## INSTALLATION

7-5

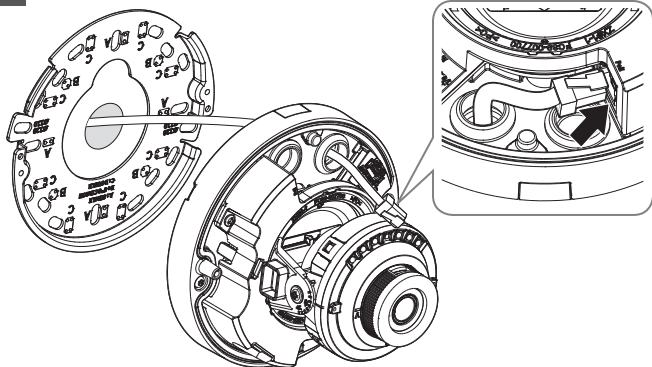

8-1

- Instalacja kabli audio/alarmu

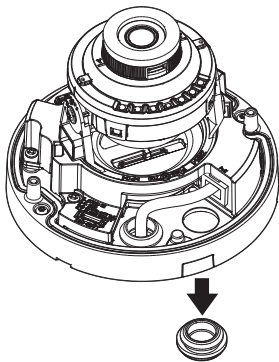

## INSTALLATION

8-2

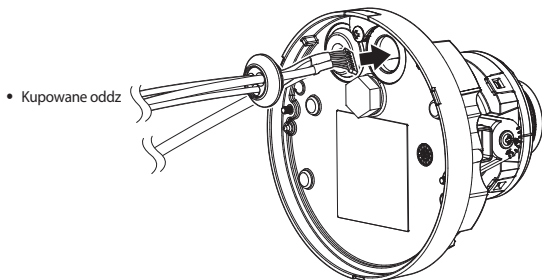

8-3

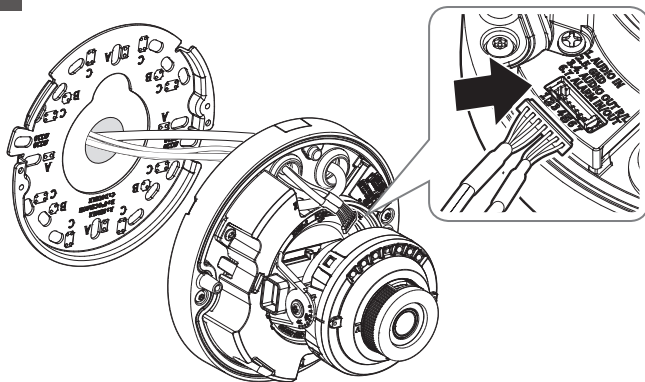



## INSTALLATION

9

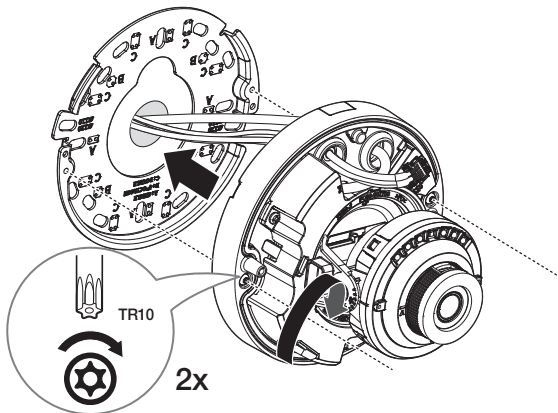

10

- Kupowane oddzielnie: Klucz WiFi, adapter OTG

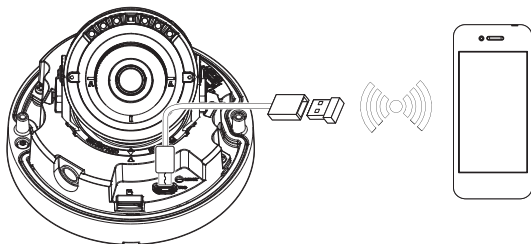



# INSTALLATION



12

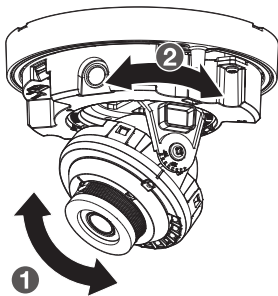
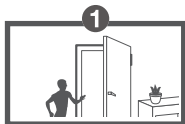

15

## INSTALLATION

13

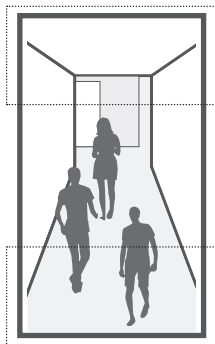
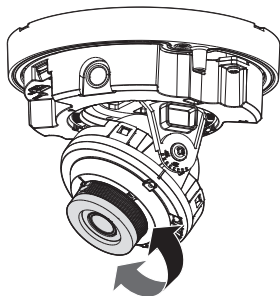

16

## INSTALLATION

---

14

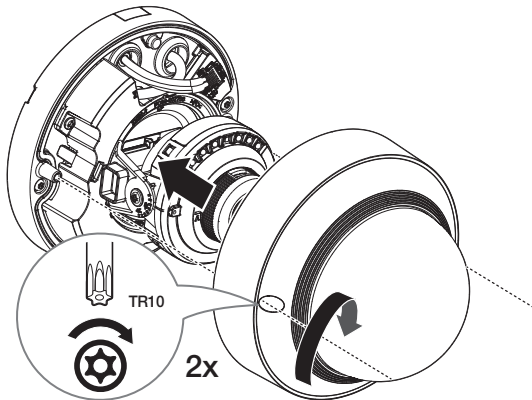

## INSTALLATION

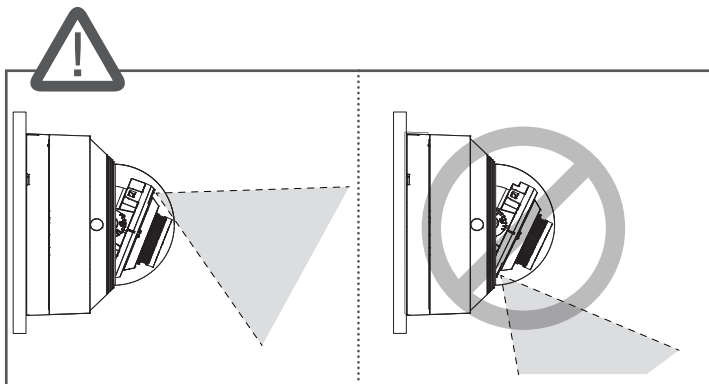
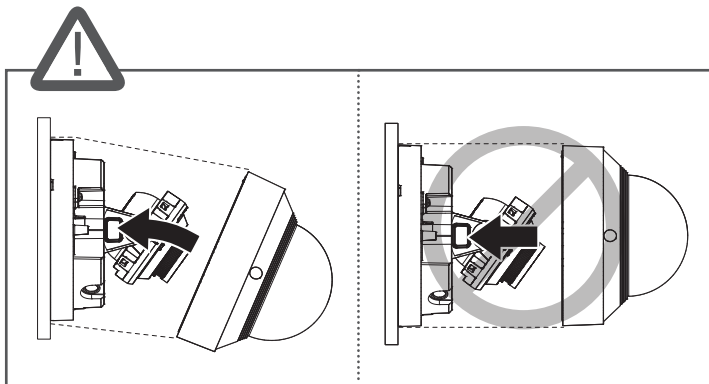

## INSTALLATION

---

15

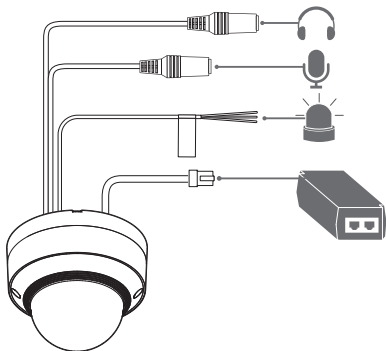

16

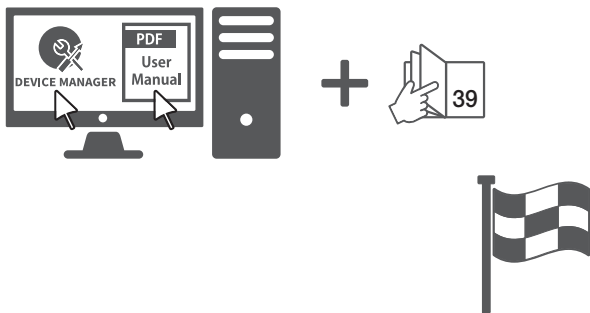

## COMPONENT

---

Aksesoria nie są identyczne i zależą od kraju sprzedaży.

- QND-C8013R/QND-C8023R

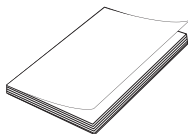
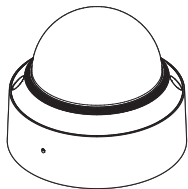

**I** Opcje (Kupowane oddz)

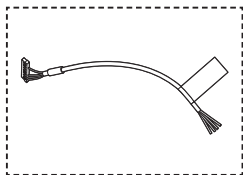

SPP-C7200



# INSTALLATION

1

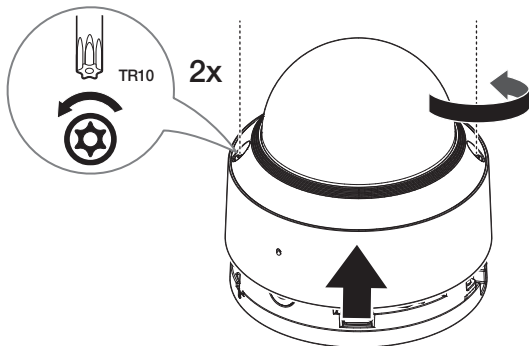

2

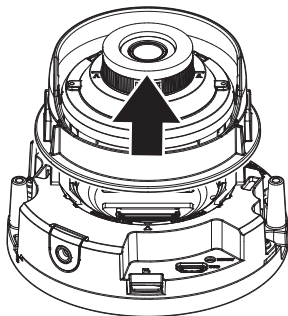

## INSTALLATION

3

- Kupowane oddz.: Karta Micro SD

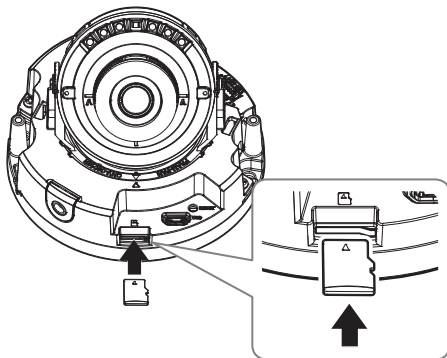

4

- Instalacja bezpośrednio na ścianie/suficie

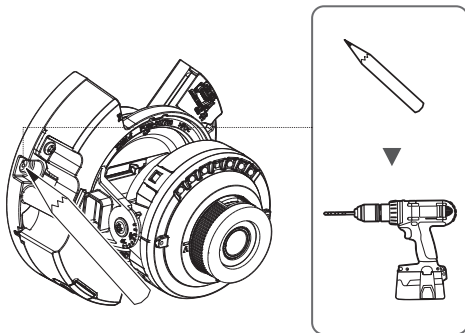

## INSTALLATION

5

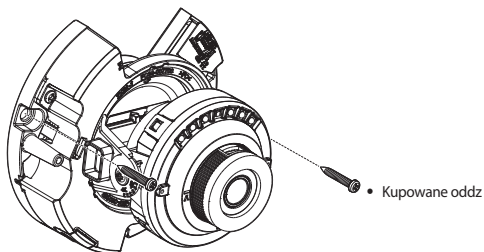

6

• Instalacja kabla sieciowego

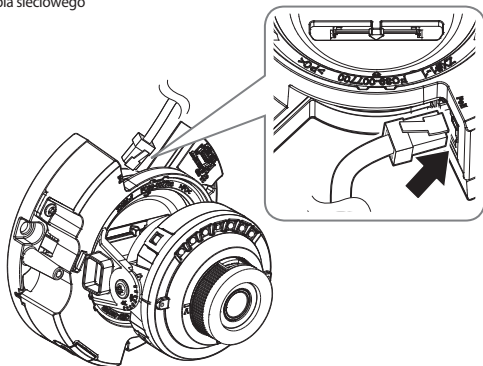

## INSTALLATION

7

- Instalacja kabla alarmu

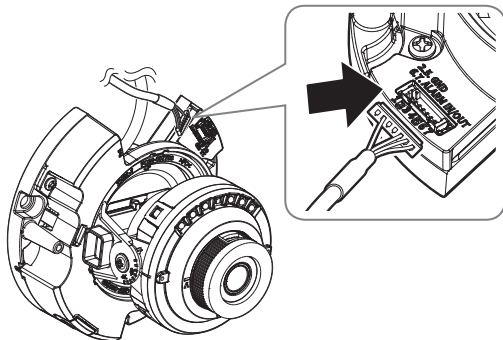

8

- Kupowane oddzielnie: Klucz WiFi, adapter OTG

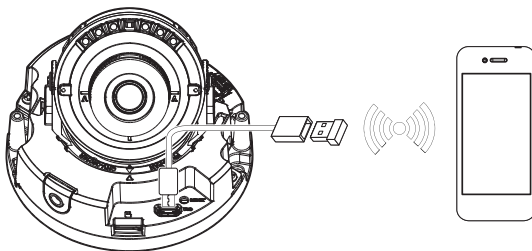



# INSTALLATION



10

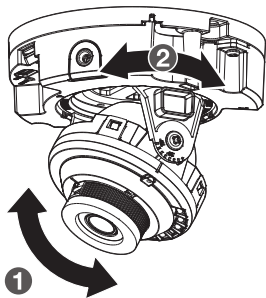
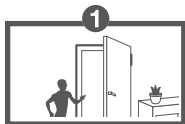

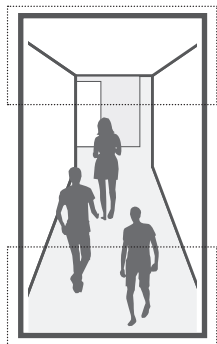
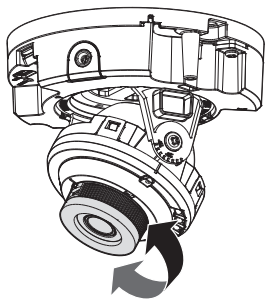

## INSTALLATION

---

12

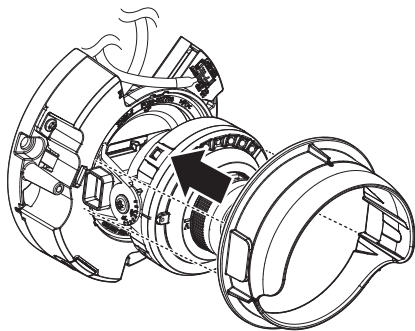

13

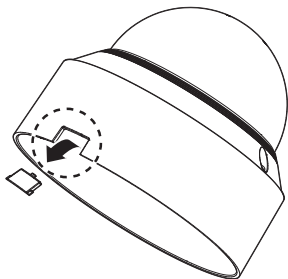



# INSTALLATION

14

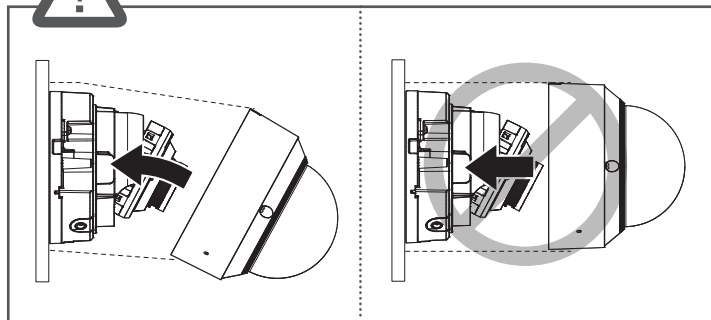
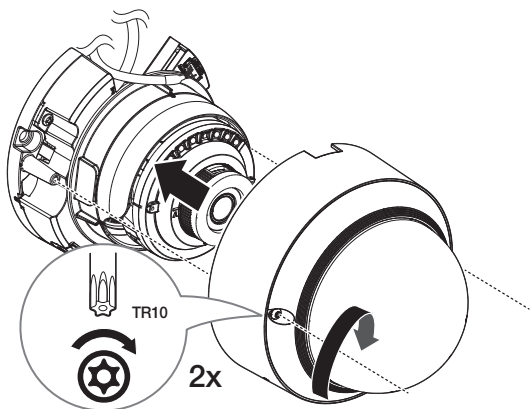

# INSTALLATION

---

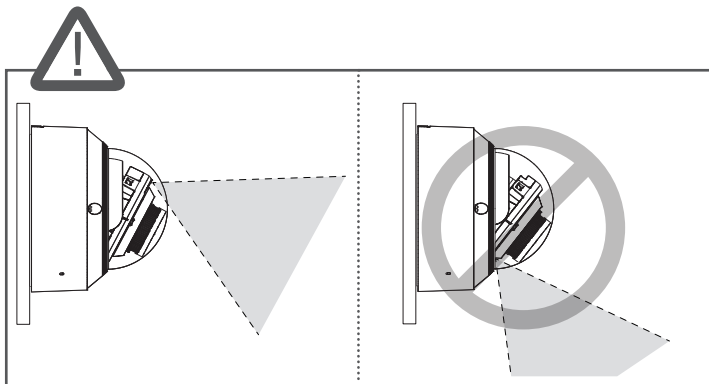

## INSTALLATION

---

15

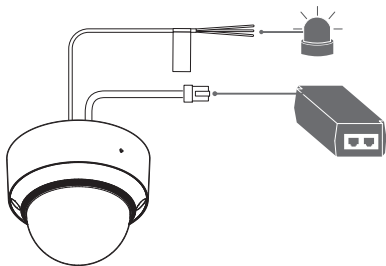

16

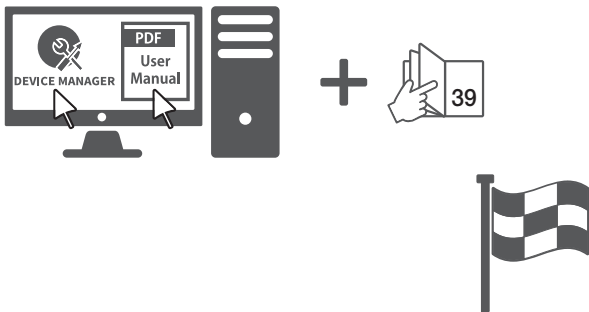

31

## COMPONENT

---

Aksesoria nie są identyczne i zależą od kraju sprzedaży.

- QNO-C8013R/QNO-C8023R

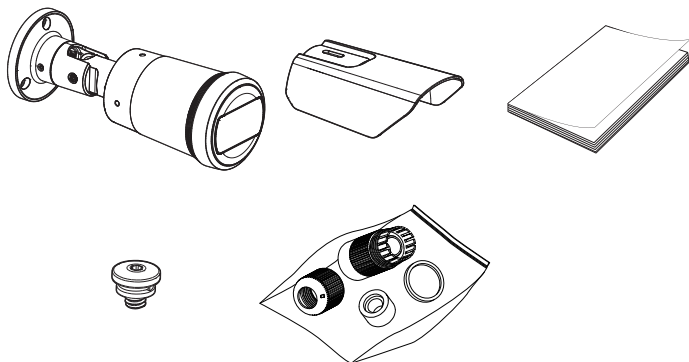

# INSTALLATION

1

- Kupowane oddz.: Karta Micro SD

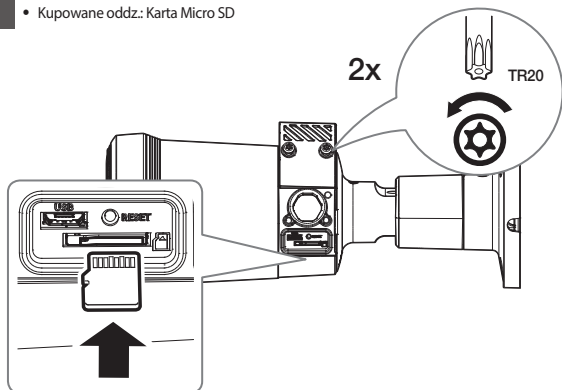

2

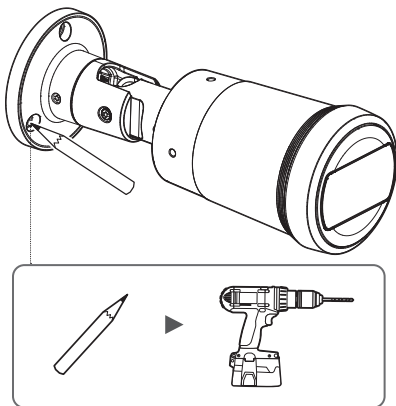

## INSTALLATION

3

- Instalacja kabla sieciowego (IP66)

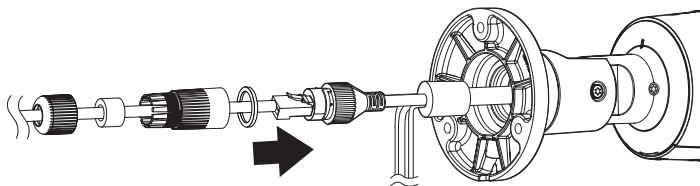

4

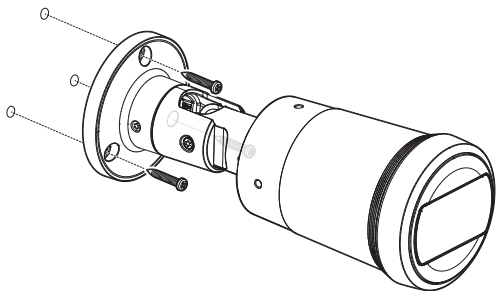

# INSTALLATION

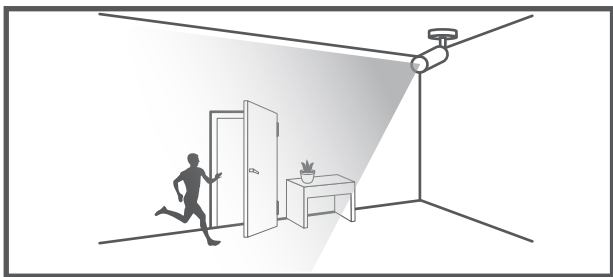

5

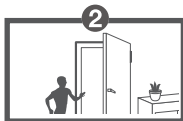
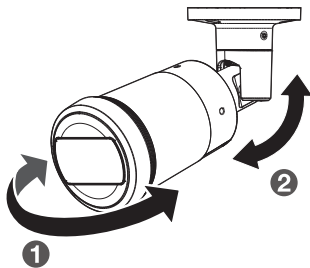

## INSTALLATION

6

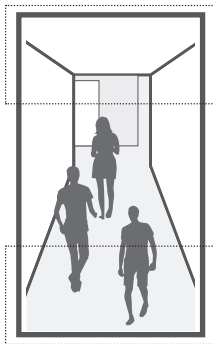
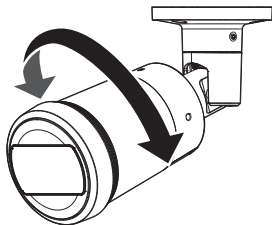



## INSTALLATION

7

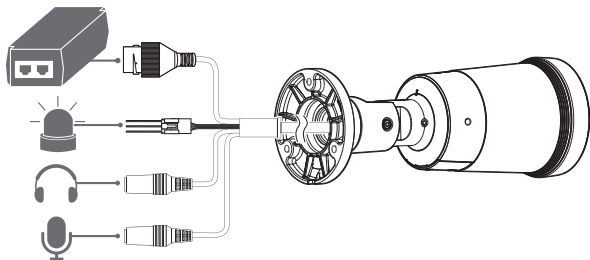

8

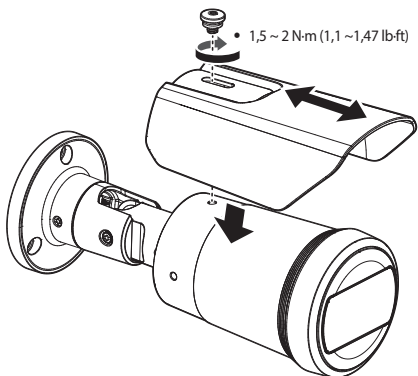

# INSTALLATION

---

9

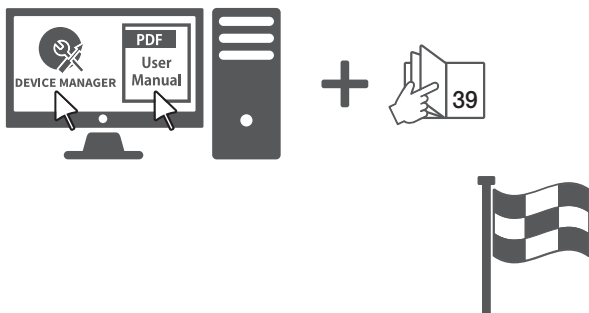

## USTAWIENIA HASŁA

Pierwsze użycie produktu wiąże się z koniecznością rejestracji loginu i hasła.



- W przypadku nowego hasła składającego się z 8 do 9 znaków musisz użyć co najmniej 3 z następujących: wielkie/małe litery, cyfry i znaki specjalne. W przypadku hasła składającego się z 10 lub więcej znaków musisz użyć co najmniej 2 z wyżej wymienionych znaków. (obsługa do 64 znaków)
  - Dozwolone znaki specjalne :  
~!@#\$%^&\*()\_+={}|~\|v:'''<>.,?/
- Hasło nie może posiadać spacji.
- Dla poprawy bezpieczeństwa nie zaleca się powtarzania tych samych znaków po kolei ani używania kolejnych znaków klawiatury.
- Jeżeli hasło zostało utracone, nacisnąć przycisk [RESET] i inicjować produkt. Zatem hasło należy zapamiętać, lub zapisać.

## LOGOWANIE

Przy każdej próbie uzyskania dostępu do kamery zostanie wyświetlone okno logowania. Wprowadź ID użytkownika i hasło, aby uzyskać dostęp do kamery.

- 1 Wpisz słowo „admin” w polu <User Name>.
- 2 Wprowadź hasło w polu <Password>.
- 3 Kliknij przycisk [Sign in].

## ŁĄCZENIE Z SIECIĄ WiFi

### Ustawienia kamery

- 1 Adapter OTG (5 styków) i klucz WiFi podłącz do gniazda Micro USB.

### Ustawienia smartfonu

- 1 Zainstaluj aplikację instalacyjną Wisenet.
- 2 Po włączeniu sieci WiFi wybierz identyfikator SSID kamery.
- 3 Uruchom aplikację instalacyjną Wisenet.
- 4 Po zalogowaniu się do kamery nastąpi połączenie z obrazem wideo.
  - Wideo zostanie odtworzone bez logowania się podczas początkowego nawiązywania połączenia.
- 5 Można ustawiać kąt widzenia, obserwując wideo przez smartfon.

# HEVC Advance™

Covered by patents at [patentlist.accessadvance.com](http://patentlist.accessadvance.com)



microSD, microSDHC, and microSDXC Logos are trademarks of SD-3C LLC. microSD, microSDHC, microSDXC are trademarks or registered trademarks of SD-3C, LLC in the United States, other countries or both.

# EAC

Подлежит использованию по назначению  
в нормальных условиях  
Срок службы : 7 лет.

## Türkiye Distribütörü

**EDS Elektronik Destek Sanayi ve Ticaret Ltd. Şti.**

Meclis Mah. Teraziler Cad. Hayran Sk. (Eskisi Kılıç Sk.) No: 4 Sancaktepe / İstanbul / Türkiye  
Tel +90.216.313.25.15

**ENTES ELEKTRONİK CİHAZLAR İMALAT VE TİC. A.Ş.**

Dudullu Org.San.Bölg. 1. Cad. No:23 34776 Ümraniye / İstanbul / Türkiye  
Tel +90.216.313.01.10

**TEKNOMAKS TEKNOLOJİ / TEKNOMAKS BİLİSİM**

MERDİVENKÖY MAH.DİKYOL SOK. BUSINESS İSTANBUL No:2, Kat:7, D:B67, 34732 Kadıköy / İstanbul / Türkiye  
Tel +90.212.217.54.22

Cihazın Ticaret Bakanlığına önerilen ortalama ömrü

Cihazın EEE yönetmeliklerine uygun olduğuna benzer beyan

